

DATA SHEET

MODULETEK: XFP-10G-DWDM-ER-xx.xx-x-C10

10GBASE 40km DWDM XFP Optical Transceiver

XFP-10G-DWDM-ER-xx.xx-x-C10 Overview

ModuleTek's XFP-10G-DWDM-ER-xx.xx-x-C10 10Gb/s 40km DWDM XFP optical transceivers are designed for Storage, IP network and SONET/SDH, it supports DWDM 10G Ethernet, DWDM 10G Fiber channel and DWDM 10G SONET/SDH interface. XFP-10G-DWDM-ER-xx.xx-x-C10 is a hot pluggable module in the Z-direction, mainly used for typical router/switch line card applications. The product implements digital diagnostics functions via a 2-wire serial interface, compliant with XFP Multi-Source Agreement (MSA) Specification.

Product Features

- Up to 9.95Gb/s to 11.3Gb/s bit rates.
- Compliant with 10G Ethernet, 10GFC, OC192 application.
- Compliant with XFP MSA.
- Standard bail mechanism for consistent installation and removal
- Temperature-stabilized EML laser
- PIN Receiver
- 100GHz ITU Grid, C Band
- Built-in digital diagnostic functions.
- Hot Pluggable XFP footprint.
- Duplex LC Connectors.
- Up to 40km on SMF
- Low power consumption (< 3W)
- RoHS Compliant
- Operating temperature range (Case Temperature)
Commercial Level : 0°C to 70°C
Industrial Level : -40°C to 85°C

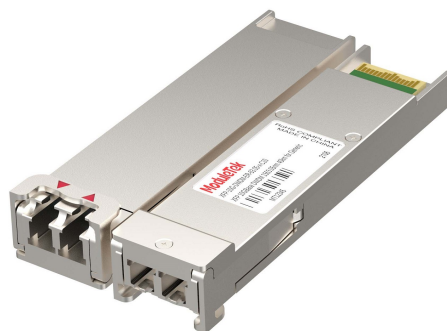

Applications

- DWDM 10G Ethernet/10G Fiber Channel
- DWDM OC192 /STM-64

Ordering Information

Part Number	ProductID	Description	Color on Clasp
XFP-10G-DWDM-ER-xx.xx-C-C10	M421500	10GBASE DWDM XFP Transceiver, Single Mode Fiber 40 km (ITU 100GHz Grid), Commercial temperature	Red
XFP-10G-DWDM-ER-xx.xx-I-C10	M365300	10GBASE DWDM XFP Transceiver, Single Mode Fiber 40 km (ITU 100GHz Grid), Industrial temperature	Red
<p>Note: 1.Product ID is the abbreviated order number of our company's standard model</p>			

For More Information:

ModuleTek Limited

Web : www.moduletek.com

Email : sales@moduletek.com

Product Selection

Product number	Description	ITU channel
XFP-10G-DWDM-ER-63.05-x-C10	10GBASE-DWDM 40km, 1563.05 nm XFP	C18
XFP-10G-DWDM-ER-62.23-x-C10	10GBASE-DWDM 40km, 1562.23 nm XFP	C19
XFP-10G-DWDM-ER-61.42-x-C10	10GBASE-DWDM 40km, 1561.42 nm XFP	C20
XFP-10G-DWDM-ER-60.61-x-C10	10GBASE-DWDM 40km, 1560.61 nm XFP	C21
XFP-10G-DWDM-ER-59.79-x-C10	10GBASE-DWDM 40km, 1559.79 nm XFP	C22
XFP-10G-DWDM-ER-58.98-x-C10	10GBASE-DWDM 40km, 1558.98 nm XFP	C23
XFP-10G-DWDM-ER-58.17-x-C10	10GBASE-DWDM 40km, 1558.17 nm XFP	C24
XFP-10G-DWDM-ER-57.36-x-C10	10GBASE-DWDM 40km, 1557.36 nm XFP	C25
XFP-10G-DWDM-ER-56.55-x-C10	10GBASE-DWDM 40km, 1556.55 nm XFP	C26
XFP-10G-DWDM-ER-55.75-x-C10	10GBASE-DWDM 40km, 1555.75 nm XFP	C27
XFP-10G-DWDM-ER-54.94-x-C10	10GBASE-DWDM 40km, 1554.94 nm XFP	C28
XFP-10G-DWDM-ER-54.13-x-C10	10GBASE-DWDM 40km, 1554.13 nm XFP	C29
XFP-10G-DWDM-ER-53.33-x-C10	10GBASE-DWDM 40km, 1553.33 nm XFP	C30
XFP-10G-DWDM-ER-52.52-x-C10	10GBASE-DWDM 40km, 1552.52 nm XFP	C31
XFP-10G-DWDM-ER-51.72-x-C10	10GBASE-DWDM 40km, 1551.72 nm XFP	C32
XFP-10G-DWDM-ER-50.92-x-C10	10GBASE-DWDM 40km, 1550.92 nm XFP	C33
XFP-10G-DWDM-ER-50.12-x-C10	10GBASE-DWDM 40km, 1550.12 nm XFP	C34
XFP-10G-DWDM-ER-49.32-x-C10	10GBASE-DWDM 40km, 1549.32 nm XFP	C35

XFP-10G-DWDM-ER-48.51-x-C10	10GBASE-DWDM 40km, 1548.51 nm XFP	C36
XFP-10G-DWDM-ER-47.72-x-C10	10GBASE-DWDM 40km, 1547.72 nm XFP	C37
XFP-10G-DWDM-ER-46.92-x-C10	10GBASE-DWDM 40km, 1546.92 nm XFP	C38
XFP-10G-DWDM-ER-46.12-x-C10	10GBASE-DWDM 40km, 1546.12 nm XFP	C39
XFP-10G-DWDM-ER-45.32-x-C10	10GBASE-DWDM 40km, 1545.32 nm XFP	C40
XFP-10G-DWDM-ER-44.53-x-C10	10GBASE-DWDM 40km, 1544.53 nm XFP	C41
XFP-10G-DWDM-ER-43.73-x-C10	10GBASE-DWDM 40km, 1543.73 nm XFP	C42
XFP-10G-DWDM-ER-42.94-x-C10	10GBASE-DWDM 40km, 1542.94 nm XFP	C43
XFP-10G-DWDM-ER-42.14-x-C10	10GBASE-DWDM 40km, 1542.14 nm XFP	C44
XFP-10G-DWDM-ER-41.35-x-C10	10GBASE-DWDM 40km, 1541.35 nm XFP	C45
XFP-10G-DWDM-ER-40.56-x-C10	10GBASE-DWDM 40km, 1540.56 nm XFP	C46
XFP-10G-DWDM-ER-39.77-x-C10	10GBASE-DWDM 40km, 1539.77 nm XFP	C47
XFP-10G-DWDM-ER-38.98-x-C10	10GBASE-DWDM 40km, 1538.98 nm XFP	C48
XFP-10G-DWDM-ER-38.19-x-C10	10GBASE-DWDM 40km, 1538.19 nm XFP	C49
XFP-10G-DWDM-ER-37.40-x-C10	10GBASE-DWDM 40km, 1537.40 nm XFP	C50
XFP-10G-DWDM-ER-36.61-x-C10	10GBASE-DWDM 40km, 1536.61 nm XFP	C51
XFP-10G-DWDM-ER-35.82-x-C10	10GBASE-DWDM 40km, 1535.82 nm XFP	C52
XFP-10G-DWDM-ER-35.04-x-C10	10GBASE-DWDM 40km, 1535.04 nm XFP	C53
XFP-10G-DWDM-ER-34.25-x-C10	10GBASE-DWDM 40km, 1534.25 nm XFP	C54
XFP-10G-DWDM-ER-33.47-x-C10	10GBASE-DWDM 40km, 1533.47 nm XFP	C55
XFP-10G-DWDM-ER-32.68-x-C10	10GBASE-DWDM 40km, 1532.68 nm XFP	C56
XFP-10G-DWDM-ER-31.90-x-C10	10GBASE-DWDM 40km, 1531.90 nm XFP	C57
XFP-10G-DWDM-ER-31.12-x-C10	10GBASE-DWDM 40km, 1531.12 nm XFP	C58
XFP-10G-DWDM-ER-30.33-x-C10	10GBASE-DWDM 40km, 1530.33 nm XFP	C59
XFP-10G-DWDM-ER-29.55-x-C10	10GBASE-DWDM 40km, 1529.55 nm XFP	C60
XFP-10G-DWDM-ER-28.77-x-C10	10GBASE-DWDM 40km, 1528.77 nm XFP	C61

Absolute Maximum Ratings

Parameter	Symbol	Min	Typ	Max	Unit	Remarks
Storage Ambient Temperature	T _S	-40		85	°C	
Supply Voltage 5V	V _{CC5}	-0.5		5.5		
Supply Voltage 3.3V	V _{CC3}	-0.5		4	V	

General Specifications

Parameter	Symbol	Min	Typ	Max	Unit	Remarks
Data Rate	DR	9.95		11.3	Gb/s	
Bit Error Rate	BER			10^{-12}		
Total Power Consumption	P			3	W	
Supply Voltage -5V	V _{CC5}	4.75	5.0	5.25	V	1
Supply Voltage -3.3V	V _{CC3}	3.14		3.46	V	1
Supply Current -V _{CC5} supply	I _{CC5}			200		
Supply Current -V _{CC3} supply	I _{CC3}			500	mA	
Operating Temperature	T _C	-40		85	°C	2

Notes:

- 1.Operating Environment
- 2.Case temperature

Link Distances

Data Rate	Fiber Type	Distance Range (km)
9.95~11.3 Gb/s	9/125um SMF	40

Optical - Characteristics - Transmitter

$V_{CC5}=4.75V$ to $5.25V$, $V_{CC3}=3.14V$ to $3.46V$, $T_C=-40^{\circ}C$ to $85^{\circ}C$

Parameter	Symbol	Min	Typ	Max	Unit	Remarks
Optical Center Wavelength	λ_C	$\lambda_C-0.1$	λ_C	$\lambda_C+0.1$	nm	1
Output Optical Power	P_{TX}	-4		4	dBm	2
Extinction Ratio	ER	8.2			dB	
Side Mode Suppression Ratio	SMSR	30			dB	
Relative Intensity Noise	RIN			-130	dB/Hz	
Transmitter Dispersion Penalty	TDP			2	dB	
Launch Power of OFF Transmitter	P_{OUT_OFF}			-30	dBm	2
Transmitter Jitter (Peak-to-Peak)	TJ			0.1	UI	

Notes:

1. λ =specified ITU Grid wavelength
2. Average

Optical - Characteristics - Receiver

$V_{CC5}=4.75V$ to $5.25V$, $V_{CC3}=3.14V$ to $3.46V$, $T_C=-40^{\circ}C$ to $85^{\circ}C$

Parameter	Symbol	Min	Typ	Max	Unit	Remarks
Center Wavelength Range	λ_C	1260		1600	nm	
Optical Input Power	P_{RX}	-16		-1	dBm	
Receiver Sensitivity @10.3Gb/s	R_{X_SEN}			-16	dBm	1
Receiver Reflectance	TR_{RX}			-27	dB	
LOS Assert	LOS_A	-25			dBm	
LOS De-Assert	LOS_D			-18	dBm	
LOS Hysteresis	LOS_H	0.5			dB	

Notes:

1. Measured with worst ER: $BER < 10^{-12}$; $2^{31}-1$ PRBS

Electrical - Characteristics - Transmitter

$V_{CC5}=4.75V$ to $5.25V$, $V_{CC3}=3.14V$ to $3.46V$, $T_C=-40^{\circ}C$ to $85^{\circ}C$

Parameter	Symbol	Min	Typ	Max	Unit	Remarks
Input differential impedance	R_{IN}		100		Ω	1
Differential data input swing	V_{IN_PP}	120		820	mV	
Transmit Disable Voltage	V_D	2		V_{CC}	V	2
Transmit Enable Voltage	V_{EN}	GND		$GND+0.8$	V	
Transmit Disable Assert Time				10	us	

Notes:

1. After internal AC coupling
2. Or open circuit

Electrical - Characteristics - Receiver

$V_{CC5}=4.75V$ to $5.25V$, $V_{CC3}=3.14V$ to $3.46V$, $T_C=-40^{\circ}C$ to $85^{\circ}C$

Parameter	Symbol	Min	Typ	Max	Unit	Remarks
Differential data output swing	V_{OUT_PP}	340	650	850	mV	
Data output rise/fall time (20%-80%)	t_r/t_f			38	ps	
LOS Fault	V_{LOS_A}	$V_{CC}-0.5$		V_{CC_HOST}	V	
LOS Normal	V_{LOS_D}	GND		$GND+0.5$	V	

Digital Diagnostic Functions

ModuleTek’s XFP-10G-DWDM-ER-xx.xx-x-C10 incorporates a XFP compliant 2-wire management interface which is used for serial ID, digital diagnostics, and certain control functions. It is modeled on the SFF-8472 Rev 9.3 specification modified to accommodate a single 2-wire interface address. In addition to the basic I2C read/write functionality the modules support packet error checking that, when enabled, allows the host system to confirm the validity of any read data. Details of the protocol and interface are explicitly described in the MSA. The digital diagnostics provides real-time access to operating parameters via a 2-wire serial interface, including operating temperature, laser bias current, transmitted optical power, received optical power, and operating voltage.

Digital Diagnostic Threshold Range					
Parameter		High Alarm(hex)	High Warning(hex)	Low Warning(hex)	Low Alarm(hex)
Temperature(°C)	T _C	75 (0x4B00)	70 (0x4600)	0 (0x0000)	-5 (0xFB00)
	T _I	90 (0x5A00)	85 (0x5500)	-40 (0xD800)	-45 (0xD300)
5V Voltage(V)		5.5 (0xD6D8)	5.25 (0xCD14)	4.75 (0xB98C)	4.5 (0xAFC8)
3.3V Voltage(V)		3.63 (0x8DCC)	3.46 (0x8728)	3.13 (0x7A44)	2.97 (0x7404)
1.8V Voltage(V)		1.98 (0x4D58)	1.89 (0x49D4)	1.71 (0x42CC)	1.62 (0x3F48)
Bias Current(mA)		131 (0xFFDC)	130 (0xFDE8)	20 (0x2710)	15 (0x1D4C)
Tx Power(dBm)		4.79 (0x75BE)	4.0 (0x621E)	-5.0 (0x0C5A)	-5.97(0x09E1)
Rx Power(dBm)		3.0 (0x4E20)	1.76 (0x3A98)	-16.25 (0x00ED)	-18.01 (0x009E)

Block-Diagram-of-Transceiver

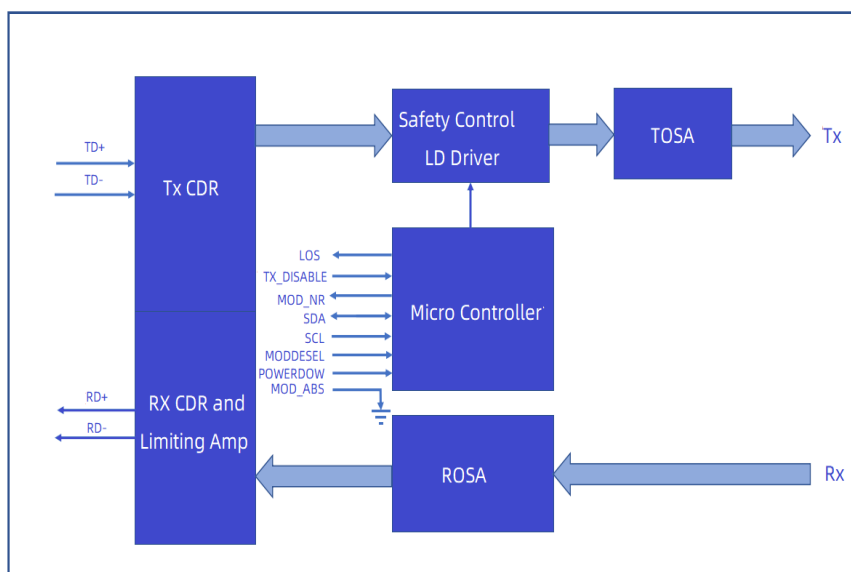

Functions Description

The transmitter consists of a laser driver chip and a TOSA (light-emitting component). The TOSA includes a laser, an electroabsorption modulator (EAM), a TEC, and a backlight diode. Unlike DML, EML TOSA uses external modulation. When the transmission rate of the system is high, the transmission distance is not only limited by the attenuation of the optical fiber, but also by the dispersion of the optical fiber, and the dispersion of the optical communication system is related to the modulation spectral width. The directly modulated laser has a large dispersion cost, and has spectral broadening, frequency chirp, and short transmission distance, so the external modulation method is adopted in the medium-long-distance transmission at a rate of 10 Gb/s. The TEC (Thermo Electric Cooler) Controls the temperature of the laser tube. When a temperature is set, the TOSA temperature of the module will remain unchanged through the control of the TEC. The wavelength of the module laser tube is related to the temperature of the laser tube. The module wavelength can be set by setting the TOSA temperature. When stable, the module has excellent wavelength stability. The electrical signal enters the optical module from the serial electrical interface and is then input to the laser driver chip. The laser driver chip supplies the bias current and the modulation current to the laser. The laser driver chip simultaneously uses an automatic optical power control (APC) feedback loop to maintain a constant average optical power of the laser output. The purpose is to eliminate the change of the output optical signal due to temperature changes and aging of the light source device. Clock Data Recovery Module (CDR) overcomes board and connector degradation by reshaping, regenerating, and reducing jitter. TX_DIS is a input pin. When TX_DIS is asserted High, the XFP module transmitter output must be turned off.

The receiver consists of a ROSA (light-receiving component) and a limiting amplifier chip, ROSA includes a PIN photodetector and a transimpedance amplifier chip. The ROSA detects the incident optical signal, converts the optical signal into an electrical signal, and outputs the electrical signal to the limiting amplifier. The limiting amplifier further amplifies the input signal and outputs a fixed amplitude electrical signal, and then shapes and synchronizes the electrical signal to the host through the CDR. Clock Data Recovery Module (CDR) overcomes board and connector degradation by reshaping, regenerating, and reducing jitter. The RX_LOS of an output pin, when LOS is high, it indicates insufficient optical power for reliable signal reception. MOD_NR is an output pin. When it is high, it indicates that the module detects the condition that invalidates the transmitter/receiver data. The transmission signal regulator loses lock, the transmitter laser fails, and the receiver signal regulator loses lock. The micro controller unit initializes the control register of laser driver, limiting amplifier and CDR. It monitors the running information from the laser driver, limiting amplifier and CDR, then reports this information to the customer.

Dimensions

Module Weight: 39g

Dust Cap Weight: 0.95g

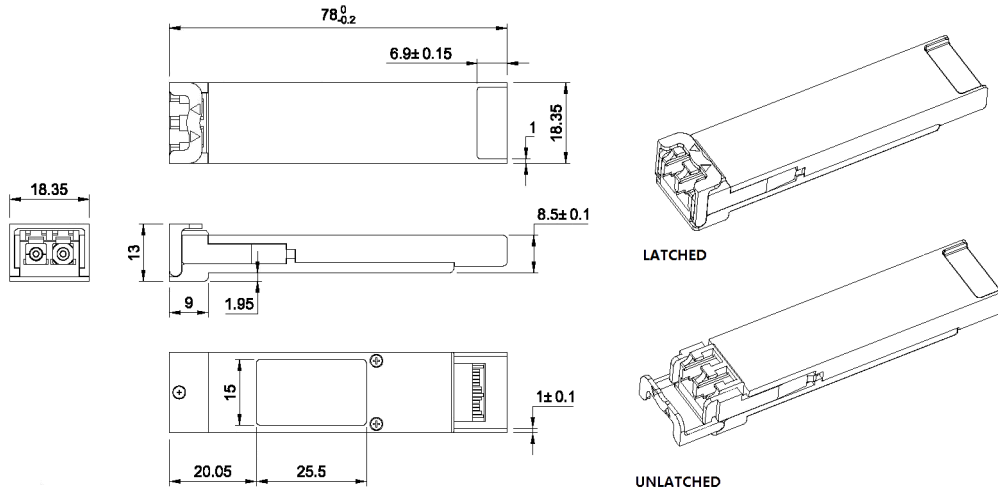

ALL DIMENSIONS ARE ± 0.2 mm UNLESS OTHERWISE SPECIFIED
UNIT: mm

Electrical Pad Layout

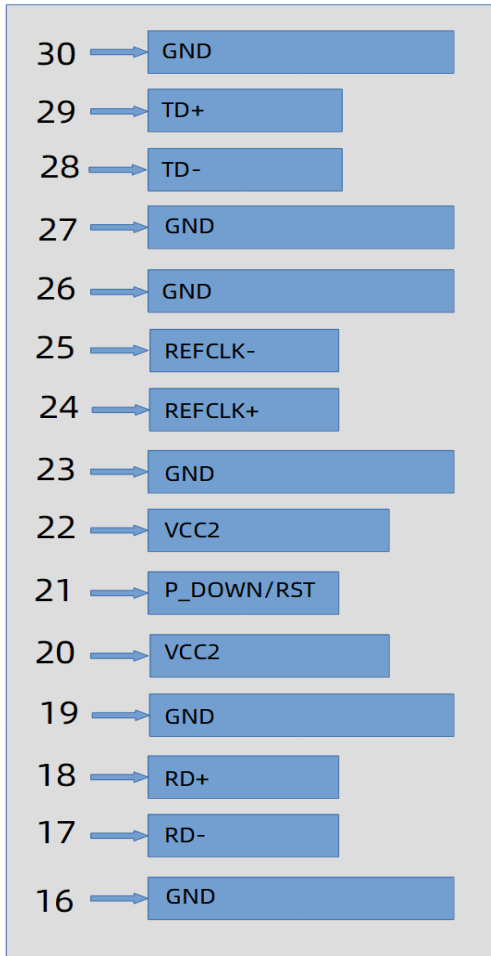

Top of Board

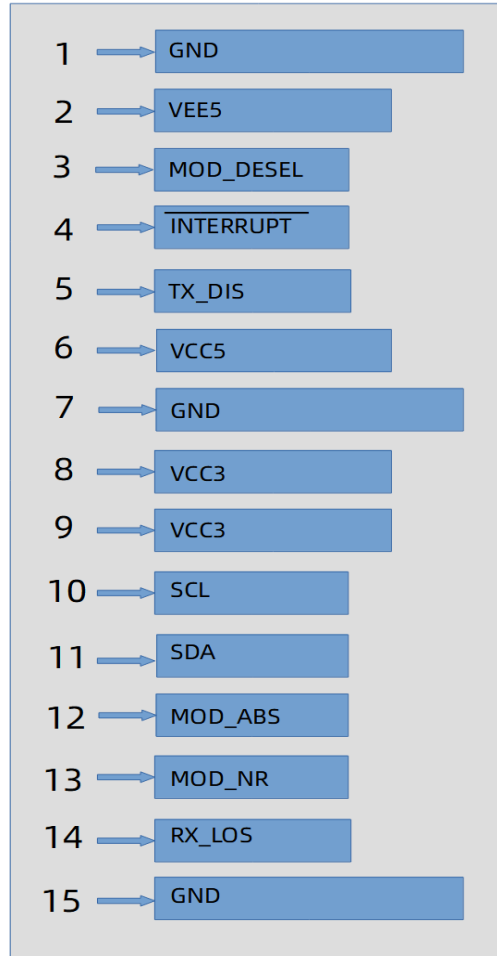

Bottom of Board

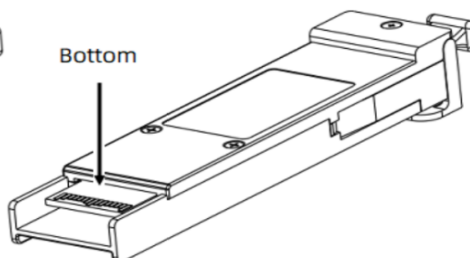
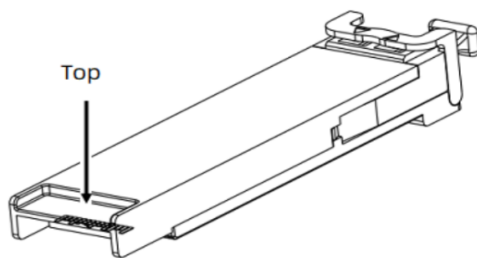

Pin Assignment - Pin1 to Pin30

PIN #	Symbol	Description	Remarks
1	GND	Module Ground	1
2	VEE5	Optional -5.2 Power Supply (Not required)	
3	Mod-Desel	Module De-select, when held low allows the module to respond to 2-wire serial interface commands	
4	$\overline{\text{Interrupt}}$	Indicates presence of an important condition which can be read over the serial 2-wire interface	2
5	TX_DISABLE	Transmitter Disable, Transmitter laser source turned off	
6	VCC5	+5V Power Supply	
7	GND	Module Ground	1
8	VCC3	+3.3V Power Supply	
9	VCC3	+3.3V Power Supply	
10	SCL	Serial 2-wire interface clock	2
11	SDA	Serial 2-wire interface data line	2
12	Mod_ABS	Module Absent; Indicates module is not present. Grounded in the module	2
13	Mod_NR	Module Not Ready; Indicates module operating fault	2
14	RX_LOS	Receiver Loss of Signal indicator	2
15	GND	Module Ground	1
16	GND	Module Ground	1
17	RD-	Receiver inverted data output	
18	RD+	Receiver non-inverted data output	
19	GND	Module Ground	1
20	VCC2	+1.8V Power Supply	
21	P_Down/RST	Power Down; When high, places the module in the low power stand-by mode and on the falling edge of P_Down initiates a module rest Reset; The falling edge initiates a complete reset of the module including the 2-wire serial interface, equivalent to a power cycle	
22	VCC2	+1.8V Power Supply	
23	GND	Module Ground	1
24	RefCLK+	Reference Clock non-inverted input, AC coupled on the host board	
25	RefCLK-	Reference Clock inverted input, AC coupled on the host board	
26	GND	Module Ground	1

27	GND	Module Ground	1
28	TD-	Transmitter inverted data input	
29	TD+	Transmitter non-inverted data input	
30	GND	Module Ground	1

Notes:

- 1. Module ground pins (GND) are isolated from the module case and chassis ground within the module
- 2. Open collector, should be pulled up with 4.7k Ω -10k Ω on host board to a voltage between 3.15V and 3.6V

References

1.10GBASE Small Form Factor Pluggable Module(XFP)Multi-Source Agreement(MSA),Rev4.5 – August 2005.