

## DATA SHEET

### MODULETEK: SFP-SGMII-GE-100FX-D12

100M 1310nm Multi Mode SFP Optical Transceiver for SGMII port

### Overview

ModuleTek's SFP-SGMII-GE-100FX-D12 100Mb/s optical transceiver is used with Gigabit switches which support SGMII ports. The module has a PHY chip inside and can be used to support FE optical interfaces on gigabit switches. The product implements digital diagnostics via a 2-wire serial interface and is compliant with the SFP Multi-Source Agreement (MSA) standard.

### Product Features

- 100Mb/s transmission rate
- Compliant with IEEE 802.3, 100BASE-FX standard
- Compliant with SFP MSA
- For SGMII ports
- 1310nm FP laser
- Standard bail mechanism
- Built-in digital diagnostic functions
- Hot-Pluggable SFP footprint
- Duplex LC Connectors
- Low power consumption
- Up to 2km on MMF
- Power supply 3.3V
- RoHS Compliant
- Operating temperature range (Case Temperature):  
Commercial Level: 0°C to 70°C



### Applications

- 100BASE-FX

## Ordering Information

Part Number	Product ID	Description	Color on Clasp
SFP-SGMII-GE-100FX-D12	M396705	SGMII 100M SFP Transceiver, LC Connectors, 1310nm laser, 2km on MMF	Black
<b>Notes:</b> 1.The product with write protection. 2.Product ID is the short order number of our product standard model.			
<b>For More Information:</b> ModuleTek Limited Web: <a href="http://www.moduletek.com">www.moduletek.com</a> Email: sales@moduletek.com			

## Absolute Maximum Ratings

Parameter	Symbol	Min	Typ	Max	Unit	Remarks
Storage Ambient Temperature	T <sub>S</sub>	-40		85	°C	
Supply Voltage	V <sub>CC</sub>	-0.5		4	V	

## General Specifications

Parameter	Symbol	Min	Typ	Max	Unit	Remarks
Data Rate	DR		125		Mb/s	
Bit Error Rate	BER			10 <sup>-12</sup>		
Total Power Consumption	P			1	W	
Supply Current	I <sub>CC</sub>			300	mA	
Supply Voltage	V <sub>CC</sub>	3.15	3.3	3.45	V	1
Operating Temperature	T <sub>C</sub>	0		70	°C	2

**Notes:**

1. The voltage required for the module to work normally
2. Case temperature

## Link Distances

Data Rate	Fiber Type	Distance Range (km)
125 Mb/s	MMF	2

## Optical - Characteristics - Transmitter

$V_{CC}=3.15V$  to  $3.45V$ ,  $T_C=0^{\circ}C$  to  $70^{\circ}C$

Parameter	Symbol	Min	Typ	Max	Unit	Remarks
Output Optical Power	$P_{TX}$	-15		-8	dBm	1
Optical Center Wavelength	$\lambda_C$	1260	1310	1360	nm	
Extinction Ratio	ER	9	11	15	dB	
Spectral Width	$\Delta\lambda$			2.5	nm	
Relative Intensity Noise	RIN			-120	dB/Hz	
Transmitter Jitter	According to IEEE 802.3 requirement					

### Notes:

1. Average

## Optical - Characteristics - Receiver

$V_{CC}=3.15V$  to  $3.45V$ ,  $T_C=0^{\circ}C$  to  $70^{\circ}C$

Parameter	Symbol	Min	Typ	Max	Unit	Remarks
Center Wavelength Range	$\lambda_C$	1260	1310	1360	nm	
Receiver Sensitivity	$R_{X\_SEN}$	-31			dBm	1
LOS Assert	$LOS_A$	-40			dBm	
LOS De-Assert	$LOS_D$			-31	dBm	
LOS Hysteresis	$LOS_H$	0.5		4.5	dB	

### Notes:

1. Measured with worst ER:  $BER < 10^{-12}$ ;  $2^{31}-1$  PRBS

## Electrical - Characteristics - Transmitter

$V_{CC}=3.15V$  to  $3.45V$ ,  $T_C=0^{\circ}C$  to  $70^{\circ}C$

Parameter	Symbol	Min	Typ	Max	Unit	Remarks
Input differential impedance	$R_{IN}$		100		$\Omega$	
Differential data input swing	$V_{IN\_PP}$	250		1200	mV	
Transmit Disable Voltage	$V_D$	2		$V_{CC}$	V	
Transmit Enable Voltage	$V_{EN}$	GND		$GND+0.8$	V	
Transmit Disable Assert Time				10	us	

## Electrical - Characteristics - Receiver

$V_{CC}=3.15V$  to  $3.45V$ ,  $T_C=0^{\circ}C$  to  $70^{\circ}C$

Parameter	Symbol	Min	Typ	Max	Unit	Remarks
Differential data output swing	$V_{OUT\_PP}$	300	500	800	mV	
Data output rise time (20%-80%)	$t_r$			3000	ps	
Data output fall time (20%-80%)	$t_f$			3000	ps	
LOS Fault	$V_{LOS\_A}$	$V_{CC}-0.5$		$V_{CC\_HOST}$	V	
LOS Normal	$V_{LOS\_D}$	GND		$GND+0.5$	V	

## Digital Diagnostic Functions

The SFP-SGMII-GE-100FX-D12 optical Transceiver has digital diagnostics. The product supports the 2-wire serial communication protocol defined in the SFP MSA and accesses digital diagnostic information via a 2-wire interface at address 0xA2. The digital diagnosis defaults to internal calibration. The micro control unit inside the module can access the module's operating parameters in real time, including operating temperature, bias current, output optical power, received optical power, and operating voltage. The module implements the alarm function of the SFP MSA.

## DDM Threshold Information

Parameter	Symbol	Alarm High	Alarm Low	Warning High	Warning Low	Unit
Temperature	Temp	75(4B00)	-5(FB00)	70(4600)	0(0000)	°C
Voltage	V <sub>CC</sub>	3.63(8DCC)	2.97(7404)	3.46(8728)	3.13(7A44)	V
Bias Current	I <sub>bias</sub>	100(C350)	2(03E8)	80(9C40)	4(07D0)	mA
Tx Power	P <sub>TX</sub>	-8.21(05E6)	-15.97(00FD)	-9.00(04EB)	-15.00(013C)	dBm
Rx Power	P <sub>RX</sub>	0(2710)	-35.23(0003)	-3.00(1388)	-32.22(0006)	dBm

## I2C Memory Map

Address A0					
IIC Addr	Size	Name	Description	Values(HEX)	Remarks
0	1	Identifier	SFP or SFP+	03	
1	1	Ext. Identifier	GBIC/SFP function is defined by two-wire interface ID only	04	
2	1	Connector	LC (Lucent Connector)	07	
3-10	8	Transceiver	100BASE-FX	00 00 00 20 00 00 00 00	
11	1	Encoding	4B/5B	02	
12	1	BR, Nominal	Nominal Bit Rate 100Mb/s	01	
13	1	Rate Identifier	Type of rate select functionality	00	
14	1	Length(SMF,km)	Link length supported for single mode fiber, units of km	00	
15	1	Length (SMF)	Link length supported for single mode fiber, units of 100 m	00	
16	1	Length (50um)	Link length supported for 50 um OM2 fiber, units of 10 m	C8	
17	1	Length (62.5um)	Link length supported for 62.5 um OM1 fiber, units of 10 m	C8	
18	1	Length (OM4 or copper cable)	Link length supported for 50um OM4 fiber, units of 10m	00	

19	1	Length (OM3)	Link length supported for 50 um OM3 fiber, units of 10 m	00	
20-35	16	Vendor name	MODULETEK	4D 4F 44 55 4C 45 54 45 4B 20 20 20 20 20 20 20	
36	1	Transceiver	Code for electronic or optical compatibility	00	
37-39	3	Vendor OUI	SFP vendor IEEE company ID	00 00 00	
40-55	16	Vendor PN	Part number in Order information	-	
56-59	4	Vendor rev	Revision level for part number provided by vendor (ASCII)	-	
60-61	2	Wavelength	Laser wavelength 1310nm	05 1E	
62	1	Unallocated		00	
63	1	CC BASE	Check code for Base ID Fields (addresses 0 to 62)	-	
64-65	2	Options	Indicates which optional transceiver signals are implemented	00 1A	
66	1	BR, max	Upper bit rate margin	00	
67	1	BR, min	Lower bit rate margin	00	
68-83	16	Vendor SN	Serial number provided by vendor	Programmed by Factory	
84-91	8	Date code	Year,Month,Day	Programmed by Factory	
92	1	Diagnostic Monitoring Type	Indicates which type of diagnostic monitoring is implemented (if any) in the transceiver	68	
93	1	Enhanced Options	Indicates which optional enhanced features are implemented (if any) in the transceiver	F0	
94	1	SFF-8472 Compliance	Indicates which revision of SFF-8472 the transceiver complies with.	00	
95	1	CC EXT	Check code for the Extended ID Fields (addresses 64 to 94)	-	

96-127	32	Vendor Specific	Vendor Specific EEPROM	-	
128-255	128	Vendor Specific	Vendor Specific EEPROM	-	
<b>Address A2 Low</b>					
<b>IIC Addr</b>	<b>Size</b>	<b>Name</b>	<b>Description</b>	<b>Values(HEX)</b>	<b>Remarks</b>
0-1	2	Temp High Alarm	75°C	4B 00	
2-3	2	Temp Low Alarm	-5°C	FB 00	
4-5	2	Temp High Warning	70°C	46 00	
6-7	2	Temp Low Warning	0°C	00 00	
8-9	2	Vcc High Alarm	3.63V	8D CC	
10-11	2	Vcc Low Alarm	2.97V	74 04	
12-13	2	Vcc High Warning	3.46V	87 28	
14-15	2	Vcc Low Warning	3.13V	7A 44	
16-17	2	Bias High Alarm	Bias High Alarm	C3 50	
18-19	2	Bias Low Alarm	Bias Low Alarm	03 E8	
20-21	2	Bias High Warning	Bias High Warning	9C 40	
22-23	2	Bias Low Warning	Bias Low Warning	07 D0	
24-25	2	TxPower High Alarm	TxPower High Alarm	05 E6	
26-27	2	TxPower Low Alarm	TxPower Low Alarm	00 FD	
28-29	2	TxPower High Warning	TxPower High Warning	04 EB	
30-31	2	TxPower Low Warning	TxPower Low Warning	01 3C	
32-33	2	RxPower High Alarm	RxPower High Alarm	27 10	
34-35	2	RxPower Low Alarm	RxPower Low Alarm	00 03	
36-37	2	RxPower High Warning	RxPower High Warning	13 88	
38-39	2	RxPower Low Warning	RxPower Low Warning	00 06	
40-55	16	Reserved	Reserved	FF	
56-59	4	Ext RxPwr 4	Ext RxPwr 4	00 00 00 00	
60-63	4	Ext RxPwr 3	Ext RxPwr 3	00 00 00 00	
64-67	4	Ext RxPwr 2	Ext RxPwr 2	00 00 00 00	
68-71	4	Ext RxPwr 1	Ext RxPwr 1	3F 80 00 00	
72-75	4	Ext RxPwr 0	Ext RxPwr 0	00 00 00 00	
76-77	2	Ext Bias Slope	Ext Bias Slope	01 00	

78-79	2	Ext Bias Offset	Ext Bias Offset	00 00	
80-81	2	Ext TxPower Slope	Ext TxPower Slope	01 00	
82-83	2	Ext TxPower Offset	Ext TxPower Offset	00 00	
84-85	2	Ext Temp Slope	Ext Temp Slope	01 00	
86-87	2	Ext Temp Offset	Ext Temp Offset	00 00	
88-89	2	Ext Vcc Slope	Ext Vcc Slope	01 00	
90-91	2	Ext Vcc Offset	Ext Vcc Offset	00 00	
92-94	3	Reserved	Reserved	FF	
95	1	Checksum	0-94 Byte Checksum	1A	
96-97	2	Temperature	Temperature	-	
98-99	2	Vcc	Vcc	-	
100-101	2	Bias Current	Bias Current	-	
102-103	2	Tx Power	Tx Power	-	
104-105	2	Rx Power	Rx Power	-	
106-121	16	Reserved	Reserved	FF	
122	1	Security Level	Security Level: 00=Normal Mode; 01=User Mode (Level 1); 02=Factory Mode (Level 2);	00	
123-126	4	Password Entry	Password Entry Area	00 00 00 00	
127	1	Table Selection	Page Select Byte	00	
<b>Address A2 Page 00h/01h</b>					
<b>IIC Addr</b>	<b>Size</b>	<b>Name</b>	<b>Description</b>	<b>Values(HEX)</b>	<b>Remarks</b>
128-255	128	Upper Memory Map	User Code Area	-	
<b>Address A2 Page F0h</b>					
<b>IIC Addr</b>	<b>Size</b>	<b>Name</b>	<b>Description</b>	<b>Values(HEX)</b>	<b>Remarks</b>
128-131	4	Password1 Long	Level 1 Password	00 00 10 11	
132	1	EnableBCM5461S	Enable BCM5461S Simu	01	
133	1	AlwaysEnableLos	01=Los Report Link State; 00=Always Los-Deassert	01	
134	1	DisableA0WP	00=A0 With Write Protection; 01=A0 Without Write Protection	00	
135	1	DisableA2T00T01WP	00=A2 T00T01 With Write Protection; 01=A2 T00T01 Without Write Protection	00	

**Notes:**

- 1.Password entry area Default 00000000, read out as last written value
- 2.A0 and page A2 page 00/01 with write protection, enter the security level 1 writeable

**User Mode**

Level 1 Default Password	Password Can Be Changed	Permissions
00 00 10 11	YES(A2 TF0)	1. Read And Write A0
		2. Read And Write A2 T00/T01
		3. Read And Write A2 TF0

**Note:**

- 1.Details in I2C Memory Map.

**Block-Diagram-of-Transceiver**

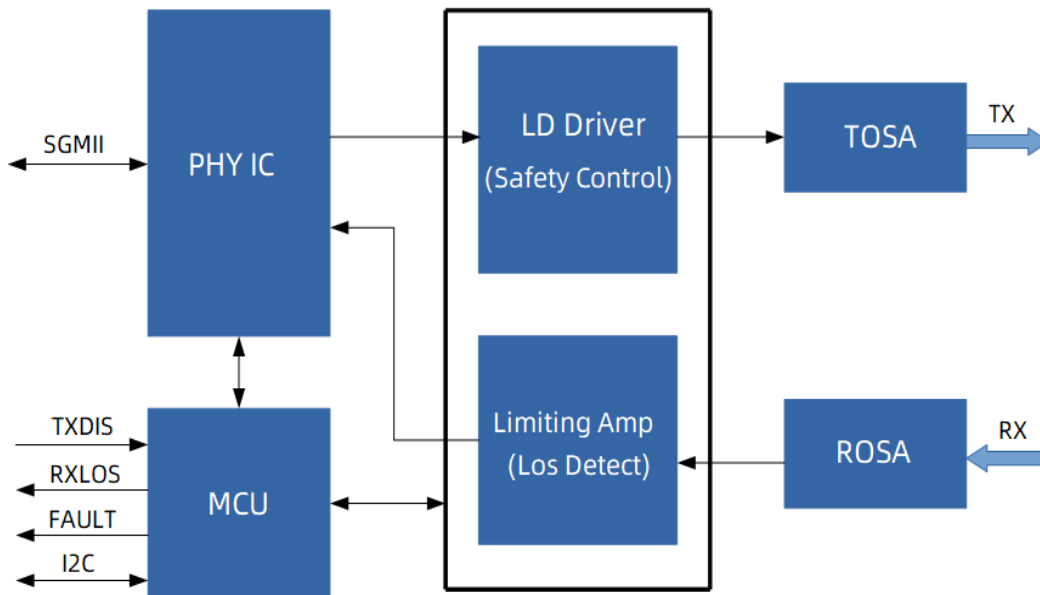

**Functions Description**

The SFP-SGMII-GE-100FX-D12 is a 100M optical module that can be used in a Gigabit switch. The module integrates a PHY chip that supports the SGMII interface. The module is interconnected to the host’s Gigabit interface via the SGMII interface. Through the SGMII protocol, an optical interface conforming to the 100FX standard is provided. The product meets SFP specifications and

supports digital diagnostics to help Gigabit switch ports interconnect with 100M legacy optical interface devices.

The transmitter of the module consists of a laser driver and a TOSA (light-emitting component). The TOSA uses a FP laser with a wavelength of 1310 nm. When the module is working, the PHY chip output signal is sent to the laser driver section. At this time, the laser driver supplies the bias current and the modulation current to the laser. The laser driver simultaneously uses an automatic optical power control (APC) feedback loop to maintain a constant average optical power of the laser output.

The receiver of the module consists of a limiting amplifier and a ROSA (light receiving component). ROSA uses a PIN with a wavelength of 1310 nm. When ROSA detects the incident light signal, the PIN converts the optical signal into a photo-generated current. The photo-generated current is amplified by a TIA (transimpedance amplifier) and converted into an electrical signal. The electrical signal is further amplified by the limiting amplifier, then outputs a fixed-amplitude electrical signal to the host.

## Dimensions

Weight: 18.0g

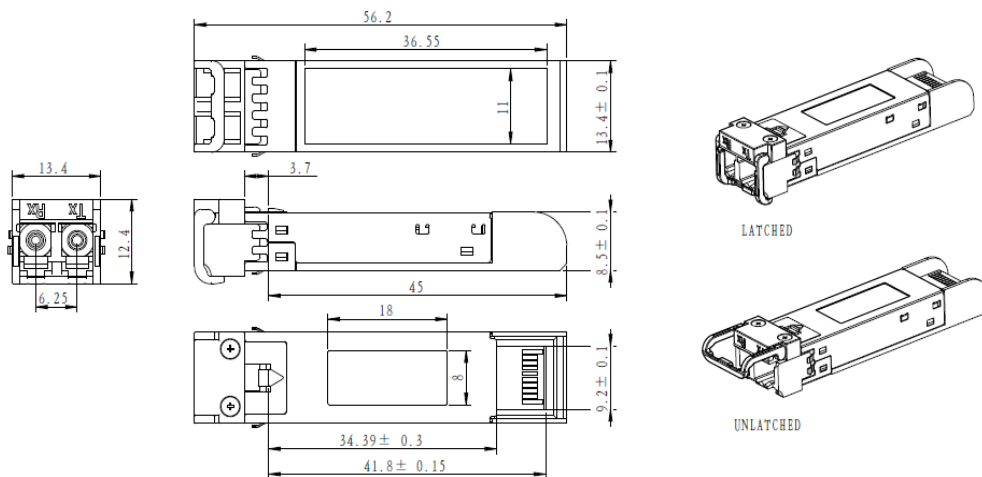

ALL DIMENSIONS ARE  $\pm 0.2$ mm UNLESS OTHERWISE SPECIFIED  
UNIT: mm

## Electrical Pad Layout

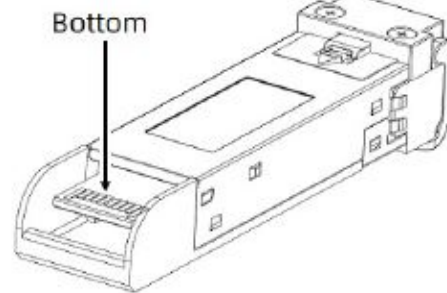
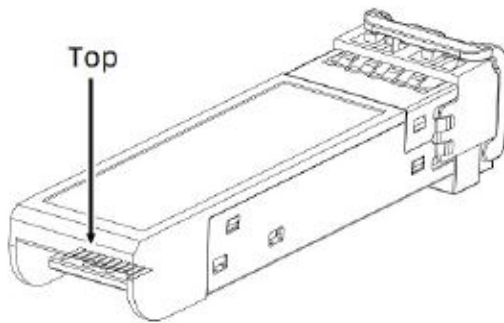
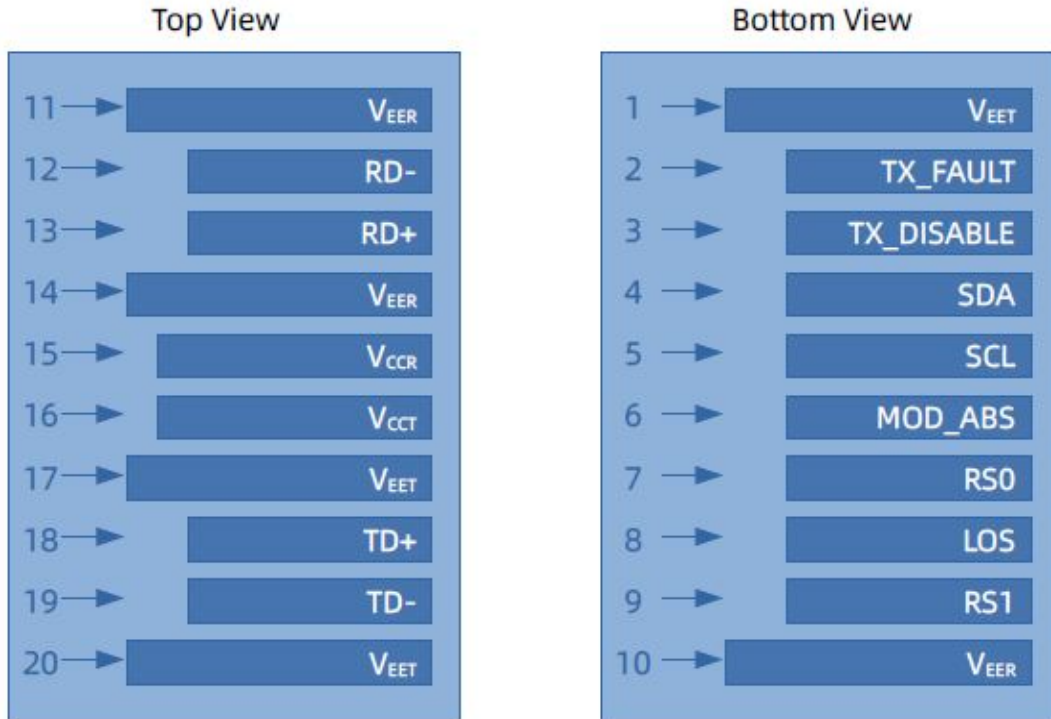

## Pin Assignment

PIN #	Symbol	Description	Remarks
1	V <sub>EET</sub>	Transmitter ground (common with receiver ground)	1
2	TX_FAULT	Transmitter Fault. Not supported	
3	TX_DISABLE	Transmitter Disable. Laser output disabled on high or open	2
4	MOD_DEF(2)	Module Definition 2. Data line for serial ID	3
5	MOD_DEF(1)	Module Definition 1. Clock line for serial ID	3
6	MOD_DEF(0)	Module Definition 0. Grounded within the module	3
7	Rate Select	No connection required	
8	LOS	Loss of Signal indication. Logic 0 indicates normal operation	4
9	V <sub>EER</sub>	Receiver ground (common with transmitter ground)	1
10	V <sub>EER</sub>	Receiver ground (common with transmitter ground)	1
11	V <sub>EER</sub>	Receiver ground (common with transmitter ground)	1
12	RD <sup>-</sup>	Receiver Inverted DATA out. AC coupled. SGMII interface	
13	RD <sup>+</sup>	Receiver Non-inverted DATA out. AC coupled. SGMII interface	
14	V <sub>EER</sub>	Receiver ground (common with transmitter ground)	1
15	V <sub>CCR</sub>	Receiver power supply	
16	V <sub>CCT</sub>	Transmitter power supply	
17	V <sub>EET</sub>	Transmitter ground (common with receiver ground)	1
18	TD <sup>+</sup>	Transmitter Non-Inverted DATA in. AC coupled. SGMII interface	
19	TD <sup>-</sup>	Transmitter Inverted DATA in. AC coupled. SGMII interface	
20	V <sub>EET</sub>	Transmitter ground (common with receiver ground)	1

### Notes:

1. Circuit ground is isolated from chassis ground
2. Disabled: T<sub>DIS</sub>>2V or open, Enabled: T<sub>DIS</sub><0.8V
3. Should Be pulled up with 4.7k –10k ohm on host board to a voltage between 2V and 3.6V
4. LOS is open collector output

## References

1. IEEE standard 802.3. IEEE Standard Department.
2. Serial-GMII Specification.