

## DATA SHEET

### MODULETEK: SFP-OC48-LR2-DWDM-xx.xx-x-D12

2.67Gb/s SFP (Small Form Pluggable) DWDM Transceiver

### SFP-OC48-LR2-DWDM-xx.xx-x-D12

ModuleTek's SFP-OC48-LR2-DWDM-xx.xx-x-D12 optical transceivers are designed for operation in Metro Access Rings and Core networks using DWDM networking equipment. They are available in 100GHz ITU Grid, C Band. The product implements digital diagnostics via a 2-wire serial bus, compliant with the INF-8074i Small Form Factor Pluggable Multi-Source Agreement and SFF-8472.

### Product Features

- Up to 2.67 Gb/s bi-directional data links
- Compliant with IEEE 802.3z Gigabit Ethernet standard
- Compliant with Fiber Channel and 2X Fiber Channel
- Compliant with ANSI-T1.646, ATM and SONET and SDH for OC-48/STM-16 (2.488Gb/s)
- Compliant with SFP MSA
- Temperature-stabilized DWDM rated DML laser transmitter
- Wavelength controlled within  $\pm 0.1\text{nm}$  over the entire lifetime and operating temperature range
- Hot-pluggable SFP footprint
- 100GHz ITU Grid, C Band
- Receiver with APD
- Duplex LC connector
- Built-in digital diagnostic functions
- Up to 120km on SMF
- Single power supply 3.3V
- Power consumption <1.5W
- RoHS Compliant
- Class 1 laser product complies with EN 60825-1
- Operating temperature range (Case Temperature) :
  - Commercial Level : 0°C to 70°C
  - Industrial Level : -40°C to 85°C



## Applications

- DWDM NETWORKS
- SONET NETWORKS

## Ordering Information

Part Number	Product ID	Description	Color on Clasp
SFP-OC48-LR2-DWDM-xx.xx-C-D12	M435204	FC/2FC/GE/SONET OC-48/SDH STM-16 DWDM SFP Transceiver, Single Mode Fiber (ITU 100GHz Grid)120km, Commercial Level	Blue
SFP-OC48-LR2-DWDM-xx.xx-I-D12	M435205	FC/2FC/GE/SONET OC-48/SDH STM-16 DWDM SFP Transceiver, Single Mode Fiber (ITU 100GHz Grid)120km, Industrial Level	Blue
<b>Note:</b> 1.Product ID is the abbreviated order number of our company's standard model			

### For More Information:

ModuleTek Limited

Web : [www.moduletek.com](http://www.moduletek.com)

Email : sales@moduletek.com

## Product Selection

Product number	Description	ITU channel
SFP-OC48-LR2-DWDM-66.31-x-D12	DWDM SFP Transceiver 1566.31 nm	14
SFP-OC48-LR2-DWDM-65.50-x-D12	DWDM SFP Transceiver 1565.50 nm	15
SFP-OC48-LR2-DWDM-64.68-x-D12	DWDM SFP Transceiver 1564.68 nm	16
SFP-OC48-LR2-DWDM-63.86-x-D12	DWDM SFP Transceiver 1563.86 nm	17
SFP-OC48-LR2-DWDM-63.05-x-D12	DWDM SFP Transceiver 1563.05 nm	18
SFP-OC48-LR2-DWDM-62.23-x-D12	DWDM SFP Transceiver 1562.23 nm	19
SFP-OC48-LR2-DWDM-61.42-x-D12	DWDM SFP Transceiver 1561.42 nm	20
SFP-OC48-LR2-DWDM-60.61-x-D12	DWDM SFP Transceiver 1560.61 nm	21
SFP-OC48-LR2-DWDM-59.79-x-D12	DWDM SFP Transceiver 1559.79 nm	22
SFP-OC48-LR2-DWDM-58.98-x-D12	DWDM SFP Transceiver 1558.98 nm	23
SFP-OC48-LR2-DWDM-58.17-x-D12	DWDM SFP Transceiver 1558.17 nm	24
SFP-OC48-LR2-DWDM-57.36-x-D12	DWDM SFP Transceiver 1557.36 nm	25
SFP-OC48-LR2-DWDM-56.55-x-D12	DWDM SFP Transceiver 1556.55 nm	26
SFP-OC48-LR2-DWDM-55.75-x-D12	DWDM SFP Transceiver 1555.75 nm	27

SFP-OC48-LR2-DWDM-54.94-x-D12	DWDM SFP Transceiver 1554.94 nm	28
SFP-OC48-LR2-DWDM-54.13-x-D12	DWDM SFP Transceiver 1554.13 nm	29
SFP-OC48-LR2-DWDM-53.33-x-D12	DWDM SFP Transceiver 1553.33 nm	30
SFP-OC48-LR2-DWDM-52.52-x-D12	DWDM SFP Transceiver 1552.52 nm	31
SFP-OC48-LR2-DWDM-51.72-x-D12	DWDM SFP Transceiver 1551.72 nm	32
SFP-OC48-LR2-DWDM-50.92-x-D12	DWDM SFP Transceiver 1550.92 nm	33
SFP-OC48-LR2-DWDM-50.12-x-D12	DWDM SFP Transceiver 1550.12 nm	34
SFP-OC48-LR2-DWDM-49.32-x-D12	DWDM SFP Transceiver 1549.32 nm	35
SFP-OC48-LR2-DWDM-48.51-x-D12	DWDM SFP Transceiver 1548.51 nm	36
SFP-OC48-LR2-DWDM-47.72-x-D12	DWDM SFP Transceiver 1547.72 nm	37
SFP-OC48-LR2-DWDM-46.92-x-D12	DWDM SFP Transceiver 1546.92 nm	38
SFP-OC48-LR2-DWDM-46.12-x-D12	DWDM SFP Transceiver 1546.12 nm	39
SFP-OC48-LR2-DWDM-45.32-x-D12	DWDM SFP Transceiver 1545.32 nm	40
SFP-OC48-LR2-DWDM-44.53-x-D12	DWDM SFP Transceiver 1544.53 nm	41
SFP-OC48-LR2-DWDM-43.73-x-D12	DWDM SFP Transceiver 1543.73 nm	42
SFP-OC48-LR2-DWDM-42.94-x-D12	DWDM SFP Transceiver 1542.94 nm	43
SFP-OC48-LR2-DWDM-42.14-x-D12	DWDM SFP Transceiver 1542.14 nm	44
SFP-OC48-LR2-DWDM-41.35-x-D12	DWDM SFP Transceiver 1541.35 nm	45
SFP-OC48-LR2-DWDM-40.56-x-D12	DWDM SFP Transceiver 1540.56 nm	46
SFP-OC48-LR2-DWDM-39.77-x-D12	DWDM SFP Transceiver 1539.77 nm	47
SFP-OC48-LR2-DWDM-38.98-x-D12	DWDM SFP Transceiver 1538.98 nm	48
SFP-OC48-LR2-DWDM-38.19-x-D12	DWDM SFP Transceiver 1538.19 nm	49
SFP-OC48-LR2-DWDM-37.40-x-D12	DWDM SFP Transceiver 1537.40 nm	50
SFP-OC48-LR2-DWDM-36.61-x-D12	DWDM SFP Transceiver 1536.61 nm	51
SFP-OC48-LR2-DWDM-35.82-x-D12	DWDM SFP Transceiver 1535.82 nm	52
SFP-OC48-LR2-DWDM-35.04-x-D12	DWDM SFP Transceiver 1535.04 nm	53
SFP-OC48-LR2-DWDM-34.25-x-D12	DWDM SFP Transceiver 1534.25 nm	54
SFP-OC48-LR2-DWDM-33.47-x-D12	DWDM SFP Transceiver 1533.47 nm	55
SFP-OC48-LR2-DWDM-32.68-x-D12	DWDM SFP Transceiver 1532.68 nm	56
SFP-OC48-LR2-DWDM-31.90-x-D12	DWDM SFP Transceiver 1531.90 nm	57
SFP-OC48-LR2-DWDM-31.12-x-D12	DWDM SFP Transceiver 1531.12 nm	58
SFP-OC48-LR2-DWDM-30.33-x-D12	DWDM SFP transceiver 1530.33 nm	59
SFP-OC48-LR2-DWDM-29.55-x-D12	DWDM SFP transceiver 1529.55 nm	60
SFP-OC48-LR2-DWDM-28.77-x-D12	DWDM SFP transceiver 1528.77 nm	61

## General Specifications

Parameter	Symbol	Min	Typ	Max	Unit	Remarks
Data Rate	DR	0.622		2.67	Gb/s	
Bit Error Rate	BER		$10^{-12}$			
Operating Temperature	T <sub>C</sub>	0		70	°C	1, 4
	T <sub>I</sub>	-40		85	°C	1, 5
Storage Temperature	T <sub>STO</sub>	-40		85	°C	2
Supply Current	I <sub>CC</sub>		250	450	mA	3
Input Voltage	V <sub>CC</sub>	3.14	3.3	3.46	V	
Maximum Voltage	V <sub>MAX</sub>	-0.5		4	V	3

**Notes:**

1. Case temperature
2. Ambient temperature
3. For electrical power interface
4. Commercial temperature
5. Industrial temperature

## Optical - Characteristics - Transmitter

V<sub>CC</sub>=3.14V to 3.46V, T<sub>C</sub>

Parameter	Symbol	Min	Typ	Max	Unit	Remarks
Output Optical Power	P <sub>TX</sub>	0		5	dBm	1
Center Wavelength space			100		GHz	
Optical Center Wavelength	λ <sub>C</sub>	X-0.1	X	X+0.1	nm	
Extinction Ratio	ER	8.2			dB	
Side Mode Suppression Ratio	SMSR	30			dB	
Spectral Width (-20dB)	Δλ			0.3	nm	
Optical Rise/Fall Time (20%-80%)	t <sub>r</sub> /t <sub>f</sub>			180	ps	
Relative Intensity Noise	RIN			-120	dB/Hz	
Transmitter Jitter	TJ			100	ps	
Dispersion Power Penalty				3.0	dB	

**Notes:**

1. Class 1 Product

## Typical eye diagram

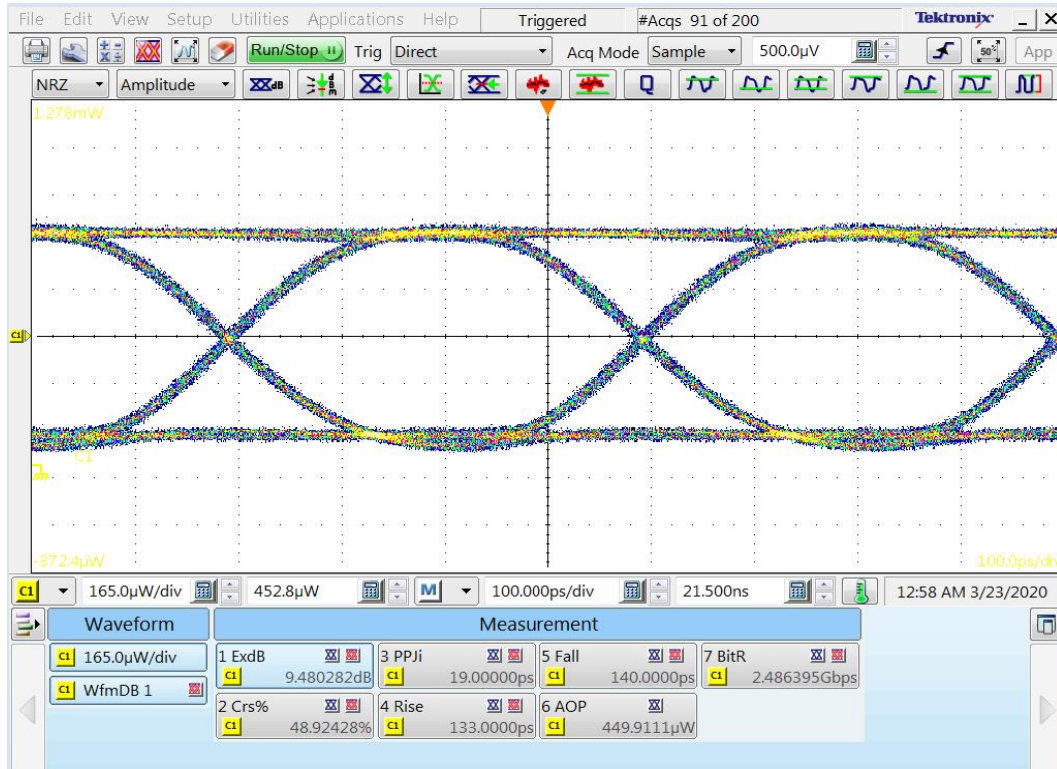

## Optical - Characteristics - Receiver

$V_{CC}=3.14V$  to  $3.46V$ ,  $T_C$

Parameter	Symbol	Min	Typ	Max	Unit	Remarks
Optical Receiver Power	$P_{RX}$	-30		-7	dBm	
Optical Center Wavelength	$\lambda_c$	1260		1620	nm	
Receiver Sensitivity @ 1.062Gb/s	$R_{X\_SEN1}$			-30	dBm	1
Receiver Sensitivity @ 1.25Gb/s	$R_{X\_SEN2}$			-30	dBm	1
Receiver Sensitivity @ 2.125Gb/s	$R_{X\_SEN3}$			-28	dBm	2
Receiver Sensitivity @ 2.488Gb/s	$R_{X\_SEN3}$			-28	dBm	2
LOS Assert	$LOS_A$	-40			dBm	
LOS De-Assert	$LOS_D$			-32	dBm	
LOS Hysteresis	$LOS_H$	0.5			dB	

### Notes:

1. Measured with a  $2^7$ -test pattern,  $BER < 10^{-12}$
2. Measured with a  $2^{23}$ -test pattern,  $BER < 10^{-12}$

## Electrical - Characteristics - Transmitter

$V_{CC}=3.14V$  to  $3.46V$ ,  $T_C$

Parameter	Symbol	Min	Typ	Max	Unit	Remarks
Input differential impedance	$R_{IN}$		100		$\Omega$	1
Single ended data input swing	$V_{IN\_PP}$	250		1200	mV	
Transmit disable voltage	$V_D$	$V_{CC}-1.3$		$V_{CC}$	V	
Transmit enable voltage	$V_{EN}$	$V_{EE}$		$V_{EE}+0.8$	V	
Transmit disable assert time				10	us	

**Notes:**

1. AC Coupled

## Electrical - Characteristics - Receiver

$V_{CC}=3.14V$  to  $3.46V$ ,  $T_C$

Parameter	Symbol	Min	Typ	Max	Unit	Remarks
Single ended data output swing	$V_{OUT\_PP}$	250		800	mV	
Data output rise/fall time (20%-80%)	$t_r / t_f$		100	175	ps	
LOS Assert	$LOS\_A$	$V_{CC}-0.5$		$V_{CC\_HOST}$	V	
LOS De-Assert	$LOS\_D$	$V_{EE}$		$V_{EE}+0.5$	V	

## A0/A2 Write Protection

Security Level 1 Password		
Password Entry ADDR	Size	Vaules(hex)
Page A2, 7BH-7EH	4	00 00 10 11

This module has the A0 / A2 write protection function. The user can enter the security level 1 working state and write the contents of Table 00 and Table 01 of the device address A0H and A2H of the module. The method to enter the working state of security level 1 is to write the security level 1 password in order in the 7BH-7EH registers of A2H of the module. After entering security level 1, the user can directly write to the contents of the A0H device address, or modify the contents of the A2H 7F table selection register to write to the contents of Table 00 or Table 01. This version of the module does not support users to modify the password of security level

1. If you need to modify the security level 1 password, you must notify our company to modify it before shipping.

## I2C Memory Map(Page A0 HEX,Unlisted Fields are Blank/Empty)

IIC ADDR	Size	Name	Description	Vaules(HEX)
0	1	Identifier	SFP	03
1	1	Extended Identifier	Extended Identifier	04
2	1	Connector	Connector Type=LC	07
3-10	8	Transceiver	Code for electronic or optical compatibility	00 0C 00 00 00 00 00 00
11	1	Encoding	Code for high speed serial encoding algorithm	03
12	1	BR,Nominal	Nominal Bit Rate 2.5Gb/s	19
13	1	Rate Identifier	Type of rate select functionality	00
14	1	Lenth(9μm)-km	120km Link Length in Thousands of Meters / SMF	78
15	1	Lenth(9μm)-100m	9-micron MMF Link Length = N/A	FF
16	1	Lenth(50μm)-10m	50-micron MMF Link Length = N/A	00
17	1	Lenth(62.5μm)-10m	62.5-micron MMF Link Length = N/A	00
18	1	Lenth(Copper)	Copper Link Length = N/A	00
19	1	Reserved	Reserved	00
20-35	16	Vendor name	ModuleTek	ASCII Format
36	1	Transceiver	Code for electronic or optical compatibility	00
37-39	3	Vendor OUI	SFP Vendor IEEE Company ID	ASCII Format
40-55	16	Vendor PN	The Part number in the Ordering Information	ASCII Format
56-59	4	Vendor Revision Number	Vendor Revision Number	Programmed by Factory
60-61	2	Wavelength	Wavelength	according to actual wavelength
62	1	Reserved	Reserved	00
63	1	CC_ BASE	Check sum of bytes 0-62	Programmed by Factory

64-65	2	Transceiver Options	1.Rx_LOS 2.Tx_FAULT 3.Tx_DIS	00 1A
66	1	BR, max	Upper bit rate margin	00
67	1	BR, min	Lower bit rate margin	00
68-83	16	Vendor SN	Vendor SN	Programmed by Factory
84-91	8	Date code	Year,Month,Day	Programmed by Factory
92	1	Monitoring Type	Internally Calibrated Received power measurement type-Average Power	68
93	1	Enhanced Options	1. Optional Alarm/Warning Flags Implemented 2. Soft Tx_DIS Monitor and Control 3. Soft Rx_LOS Monitor 4.Soft Tx_FAULT Monitor	F0
94	1	SFF-8472 Compliance	Indicates which revision of SFF-8472 the transceiver complies with	08
95	1	CC_EXT	Check sum of bytes 64-94	Programmed by Factory
96-127	32	Vendor Specific	Vendor Specific EEPROM	Programmed by Factory
128-255	128	Vendor Specific	Vendor Specific	Programmed by Factory

## Digital Diagnostic Functions

SFP-OC48-LR2-DWDM-xx.xx-x-D12 supports the 2-wire serial communication protocol as defined in SFF-8472. Digital diagnostic information is accessible over the 2-wire interface at the address 0xA2. Digital diagnostics for SFP-OC48-LR2-DWDM-xx.xx-x-D12 are internally calibrated by default. The internal micro control unit accesses the device operating parameters in real time, Such as transceiver temperature, laser bias current, transmitted optical power, received optical power and transceiver supply voltage. The module implements the alarm function of the SFF-8472, alerts the user when a particular operating parameter exceeds the factory-set normal range.

Diagnostic Threshold Range					
Parameter		High Alarm(hex)	High Warning(hex)	Low Warning(hex)	Low Alarm(hex)
Temperature (°C)	C	75 (0x4B00)	70 (0x4600)	0 (0x0000)	-5 (0xFB00)
	I	90 (0x5A00)	85 (0x5500)	-40 (0xD800)	-45 (0xD300)
Voltage (V)		3.63 (0x8DCC)	3.46 (0x8728)	3.13 (0x7A44)	2.97 (0x7404)
Bias Current (mA)		100 (0xC350)	80 (0x9C40)	4 (0x07D0)	2 (0x03E8)
Tx Power (dBm)		5.79(0x943B)	5 (0x7B86)	0 (0x2710)	-0.97 (0x1F40)
Rx Power (dBm)		-6 (0x09D0)	-7 (0x07CB)	-30 (0x000A)	-32.52 (0x0005)

## Block-Diagram-of-Transceiver

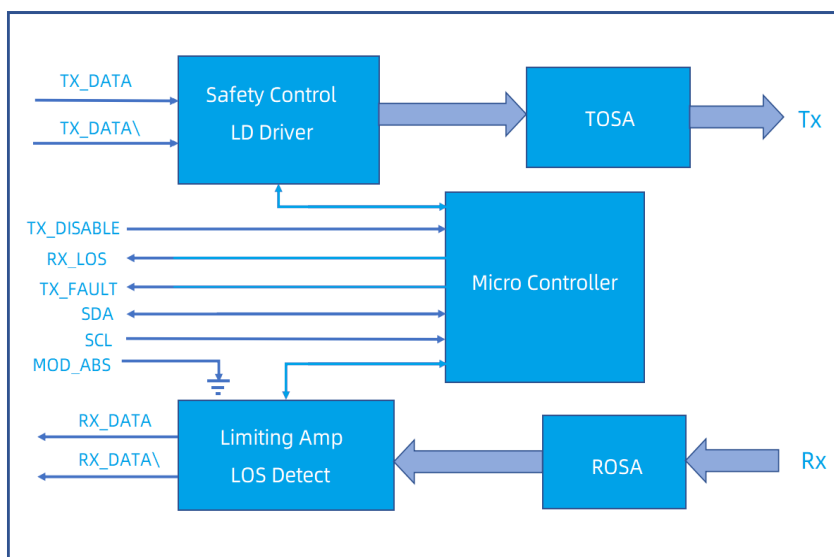

## Functions Description

The transmitter consists of a laser driver chip and a TOSA (light-emitting component). The TOSA includes a DFB laser, a TEC, and a backlight diode. TEC (Thermo Electric Cooler) Controls the temperature of the laser tube. When a temperature is set, the TOSA temperature of the module will remain unchanged through the control of the TEC. The wavelength of the module laser tube is related to the temperature of the laser tube. The module wavelength can be set by setting the TOSA temperature. When stable, the module has excellent wavelength stability. The electrical signal enters the optical module from the serial electrical interface and is then input to the laser driver chip. The laser driver chip supplies the bias current and the modulation current to the laser. The laser driver chip simultaneously uses an automatic optical power control (APC) feedback loop to maintain a constant average optical power of the laser output. The purpose is to eliminate the change of the output optical signal due to temperature changes and aging of the

light source device. When the transmitter enable pin (TX\_Disable) is high (TTL logic "1"), the laser output is turned off. When TX\_Disable is low (TTL logic "0"), the laser will turn on within 1ms. When the transmitter fault signal (TX\_Fault) is reported as high, indicates a transmitter failure caused by the transmitter's bias current or transmitted optical power or laser tube temperature exceeding a preset alarm threshold. Low indicates normal operation.

The receiver consists of a ROSA (light-receiving component) and a limiting amplifier chip, ROSA includes a APD photodetector and a transimpedance amplifier chip. The ROSA detects the incident optical signal, converts the optical signal into an electrical signal, and outputs the electrical signal to the limiting amplifier. The electrical signal is further amplified by the limiting amplifier, then outputs a fixed-amplitude electrical signal to the host. When the amplitude of the electrical signal received from the incident light conversion of the opposite optical transceiver module is lower than the set threshold, the module reports that the received signal is lost, the RX\_LOS pin is high (logic "1"), which can be used to diagnose whether the physical signal is normal. The signal is operated in TTL level. The microprocessor inside the module monitors the module's operating voltage, temperature, transmitted optical power, received optical power, and laser bias current value in real time. The host acquires this information over a 2-wire serial bus.

## Dimensions

**Module Weight: 16.5g**

**Dust Cap Weight: 0.95g**

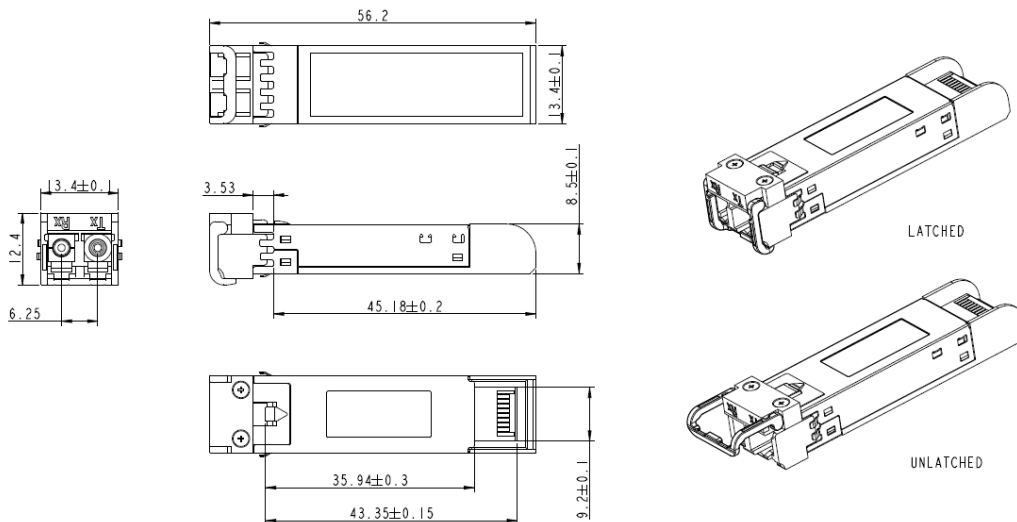

ALL DIMENSIONS ARE ±0.2mm UNLESS OTHERWISE SPECIFIED  
UNIT: mm

## Electrical Pad Layout

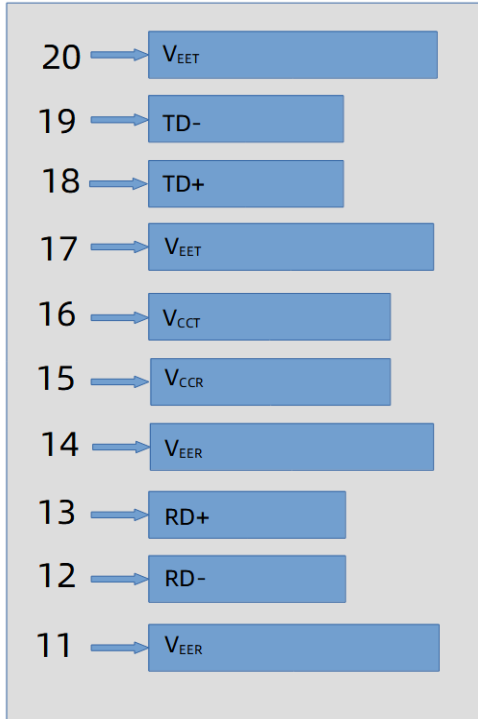

Top of Board

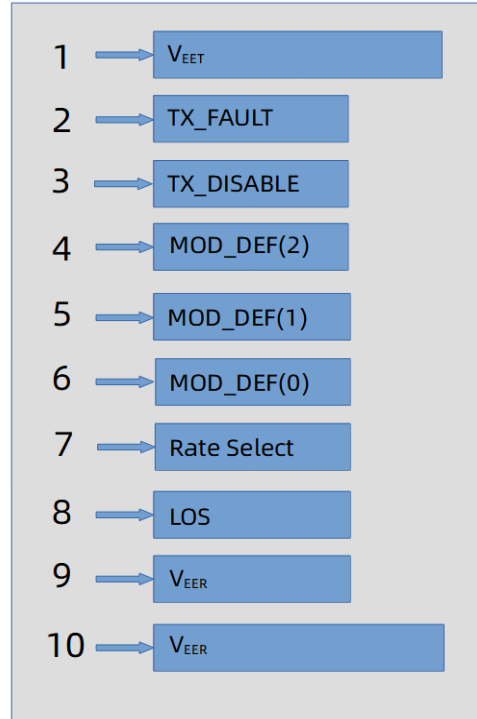

Bottom of Board

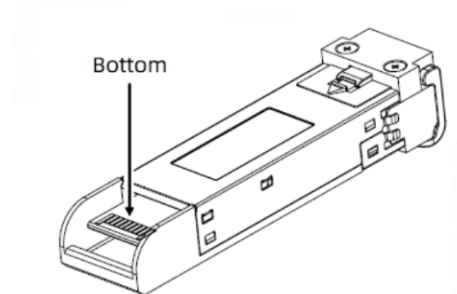
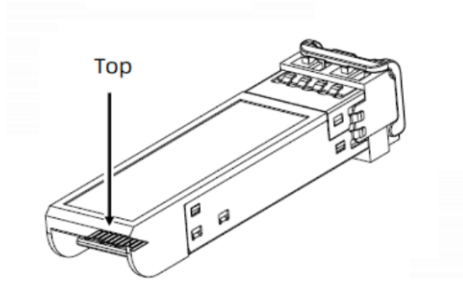

## Pin Assignment

PIN #	Symbol	Description	Remarks
1	V <sub>EET</sub>	Transmitter ground (common with receiver ground)	1
2	TX_FAULT	Transmitter Fault. Not supported	
3	TX_DISABLE	Transmitter Disable. Laser output disabled on high or open	2
4	MOD_DEF(2)	Module Definition 2. Data line for serial ID	3
5	MOD_DEF(1)	Module Definition 1. Clock line for serial ID	3
6	MOD_DEF(0)	Module Definition 0. Grounded within the module	3
7	Rate Select	No connection required	
8	LOS	Loss of Signal indication. Logic 0 indicates normal operation	4
9	V <sub>EER</sub>	Receiver ground (common with transmitter ground)	1
10	V <sub>EER</sub>	Receiver ground (common with transmitter ground)	1
11	V <sub>EER</sub>	Receiver ground (common with transmitter ground)	1
12	RD-	Receiver Inverted DATA out. AC coupled	
13	RD+	Receiver Non-inverted DATA out. AC coupled	
14	V <sub>EER</sub>	Receiver ground (common with transmitter ground)	1
15	V <sub>CCR</sub>	Receiver power supply	
16	V <sub>CCT</sub>	Transmitter power supply	
17	V <sub>EET</sub>	Transmitter ground (common with receiver ground)	1
18	TD+	Transmitter Non-Inverted DATA in. AC coupled	
19	TD-	Transmitter Inverted DATA in. AC coupled	
20	V <sub>EET</sub>	Transmitter ground (common with receiver ground)	1

### Notes:

1. Circuit ground is isolated from chassis ground
2. Disabled: T<sub>DIS</sub>>2V or open, Enabled: T<sub>DIS</sub><0.8V
3. Should Be pulled up with 4.7k –10k ohm on host board to a voltage between 2V and 3.6V
4. LOS is open collector output

## References

1. IEEE standard 802.3. IEEE Standard Department, 2005.
2. Small Form Factor Pluggable (SFP) Transceiver Multi-Source Agreement (MSA), INF-8074i.
3. Fiber Channel Draft Physical Interface Specification (FC-PI-2 Rev7.0).
4. Digital Diagnostics Monitoring Interface for Optical Transceivers –SFF-8472.
5. Fiber Channel Physical and Signaling Interface (FC-PH/PH2/PH3).
6. Bellcore GR-253 and ITU-T G.957 Specifications.