

## DATA SHEET

### MODULETEK: SFP-GE-T-x-D51

1000BASE-T SFP (Small Form Pluggable) Copper Transceiver  
1.25 Gigabit Ethernet

### Overview

ModuleTek's SFP-GE-T is a small, hot-swappable RJ45 electrical port module, compliant with Gigabit Ethernet standards and SFP Multi-Source Agreement (MSA) standards, supporting 10M/100M/1000M transmission rate. CAT5 class network cable transmission distance of up to 100 meters, good electromagnetic compatibility, compatible with various brands of hosts, widely used in data centers and enterprise networks. Access to the PHY chip registers is via the I2C interface. It supports hosts with SGMII functionality. Meet the certification requirements such as RoHS.

### Product Features

- Up to 1.25Gb/s bi-directional data links
- Support 10/100/1000BASE-T operation in host systems with SGMII interface
- Compliant with IEEE 802.3z, IEEE 802.3u, IEEE 802.3ab
- Compliant with SFP MSA
- Hot-pluggable SFP footprint
- RJ-45 connector
- Auto-sense MDI/MDIX
- Single power supply 3.3V
- RoHS Compliant
- Operating temperature range (Case Temperature):  
Commercial Level: 0°C to 70°C  
Industrial Level: -40°C to 85°C



### Applications

1.25 Gigabit Ethernet

## Ordering Information

Part Number	Product ID	Description	Operating Temperature Range
SFP-GE-T-C-D51	M009303	1000BASE-T SFP Copper RJ-45 Connector 100m , SGMII default mode	0°C to 70°C
SFP-GE-T-I-D51	M009304	1000BASE-T SFP Copper RJ-45 Connector 100m , SGMII default mode	-40°C to 85°C
<b>Notes:</b> 1. The product with write protection 2. Module based on Realtek RTL8211 development 3. Operating Temperature Range is case temperature 4. The product enables RX_LOS function 5. The product does not implement receiver suppression 6. Product ID is the short order number of our product standard model			
<b>For More Information:</b> ModuleTek Limited Web: <a href="http://www.moduletek.com">www.moduletek.com</a> Email: <a href="mailto:sales@moduletek.com">sales@moduletek.com</a>			

## General Specifications

Parameter	Symbol	Min	Typ	Max	Unit	Remarks
Data Rate	DR	10		1000	Mb/sec	1
Cable Length	CL			100	m	2
Bit Error Rate	BER			10 <sup>-12</sup>		
Storage Temperature	T <sub>STO</sub>	-40		85	°C	3
Supply Current	I <sub>CC</sub>		180	210	mA	
Input Voltage	V <sub>CC</sub>	3.14	3.3	3.46	V	
Maximum Voltage	V <sub>MAX</sub>			4	V	
Power Consumption	P		594	726	mW	

### Notes:

1. IEEE 802.3 compatible
2. Category 5 UTP
3. Ambient temperature

## High Speed Electrical Interface Host-SFP

Parameter	Symbol	Min	Typ	Max	Unit	Remarks
Single ended Input swing	$V_{IN\_PP}$	250		1200	mV	
Single ended output swing	$V_{OUT\_PP}$	275		800	mV	
Rise Time /Fall Time(20%-80%)	$t_r/t_f$		175		ps	
Tx Input impedance	$Z_{IN}$		50		ohm	1
Rx Output impedance	$Z_{OUT}$		50		ohm	1

**Notes:**

1. Single ended

## High Speed Electrical Interface Transmission Line-SFP

Parameter	Symbol	Min	Typ	Max	Unit	Remarks
Line Frequency	$F_L$		125		MHz	1
Tx Output Impedance Differential	$Z_{OUT\_TX}$		100		Ohm	2
Rx Input Impedance Differential	$Z_{IN\_RX}$		100		Ohm	2

**Notes:**

1. 5-level encoding
2. For all frequencies between 1MHz and 125MHz

## Low Speed Electrical Signal

Parameter	Symbol	Min	Typ	Max	Unit	Remarks
SFP Output Low	$V_{OL}$	0		0.5	V	1
SFP Output High	$V_{OH}$	Host_ $V_{CC}$ -0.5		Host_ $V_{CC}$ +0.3	V	1
SFP Input Low	$V_{IL}$	0		0.8	V	1
SFP Input High	$V_{IH}$	2		$V_{CC}$ +0.3	V	1

**Notes:**

1. External 4.7-10k ohm pull-up resistor required

## I2C Memory Map

Address A0					
IIC Addr	Size	Name	Description	Values (HEX)	Remarks
0	1	Identifier	SFP or SFP+	03	
1	1	Ext. Identifier	GBIC/SFP function is defined by two-wire interface ID only	04	
2	1	Connector	RJ45 (Registered Jack)	22	
3-10	8	Transceiver	1000BASE-T	00 00 00 08 00 00 00 00	
11	1	Encoding	8B/10B	01	
12	1	BR, Nominal	Nominal Bit Rate 1.3Gb/s	0D	
13	1	Rate Identifier	Type of rate select functionality	00	
14	1	Length(SMF,km)	Link length supported for single mode fiber, units of km	00	
15	1	Length (SMF)	Link length supported for single mode fiber, units of 100 m	00	
16	1	Length (50um)	Link length supported for 50 um OM2 fiber, units of 10 m	00	
17	1	Length (62.5um)	Link length supported for 62.5 um OM1 fiber, units of 10 m	00	
18	1	Length (OM4 or copper cable)	100m	64	
19	1	Length (OM3)	Link length supported for 50 um OM3 fiber, units of 10 m	00	
20-35	16	Vendor name	MODULETEK	4D 4F 44 55 4C 45 54 45 4B 20 20 20 20 20 20 20	
36	1	Transceiver	Code for electronic or optical compatibility	00	
37-39	3	Vendor OUI	SFP vendor IEEE company ID	00 00 00	
40-55	16	Vendor PN	Part number in Order information	-	

56-59	4	Vendor rev	Revision level for part number provided by vendor (ASCII)	-	
60-61	2	Wavelength	Laser wavelength (Passive/Active Cable Specification Compliance)	00 00	
62	1	Unallocated		00	
63	1	CC BASE	Check code for Base ID Fields (addresses 0 to 62)	-	
64-65	2	Options	Indicates which optional transceiver signals are implemented	00 00	
66	1	BR, max	Upper bit rate margin	00	
67	1	BR, min	Lower bit rate margin	00	
68-83	16	Vendor SN	Serial number provided by vendor	Programmed by Factory	
84-91	8	Date code	Year,Month,Day	Programmed by Factory	
92	1	Diagnostic Monitoring Type	Indicates which type of diagnostic monitoring is implemented (if any) in the transceiver	00	
93	1	Enhanced Options	Indicates which optional enhanced features are implemented (if any) in the transceiver	00	
94	1	SFF-8472 Compliance	Indicates which revision of SFF-8472 the transceiver complies with.	00	
95	1	CC EXT	Check code for the Extended ID Fields (addresses 64 to 94)	-	
96-127	32	Vendor Specific	Vendor Specific EEPROM	-	
128-255	128	Vendor Specific	Vendor Specific EEPROM	-	
<b>Address A2 Low</b>					
IIC Addr	Size	Name	Description	Values (HEX)	Remarks
0-94	95	Reserved	Reserved	FF	
95	1	Checksum	0-94 Byte Checksum	-	
96-121	26	Reserved	Reserved	FF	

122	1	Security Level	Security Level: 00=Normal Mode; 01=User Mode (Level 1); 02=Factory Mode (Level 2);	-	
123-126	4	Password Entry	Password Entry Area	00 00 00 00	
127	1	Table Selection	Page Select Byte	00	
<b>Address A2 Page 00h/01h</b>					
IIC Addr	Size	Name	Description	Values (HEX)	Remarks
128-255	128	Upper Memory Map	User Code Area	-	
<b>Address A2 Page 8Ah</b>					
IIC Addr	Size	Name	Description	Values (HEX)	Remarks
128-131	4	Firmware Version Number[4]	Firmware Version Number	-	
132-135	4	Total Running Time In Second	Total Running Time In Second	-	
<b>Address A2 Page F0h</b>					
IIC Addr	Size	Name	Description	Values (HEX)	Remarks
128-131	4	Password1 Long	Level 1 Password	00 00 10 11	
132	1	Working Mode	00=AUTO; 01=SGMII;	01	
133	1	Disable A0 WP	00=A0 With Write Protection; 01=A0 Without Write Protection	00	
134	1	Disable A2T00T01 WP	00=A2 T00T01 With Write Protection; 01=A2 T00T01 Without Write Protection	00	

**Notes:**

- 1.Password entry area default 00000000, read out as last written value
- 2.Module with write protection, enter the security level 1 writeable

## User Mode

Module	Level 1 Default Password	Password Can Be Changed	Permissions
SFP-GE-T	00001011	YES(A2 TF0)	1. Read And Write A0
			2. Read And Write A2 T00/T01
			3. Read A2 T8A
			4. Read And Write A2 TF0

**Notes:**

1.detail in I2C memory map

## Dimensions

Weight: 24.5g

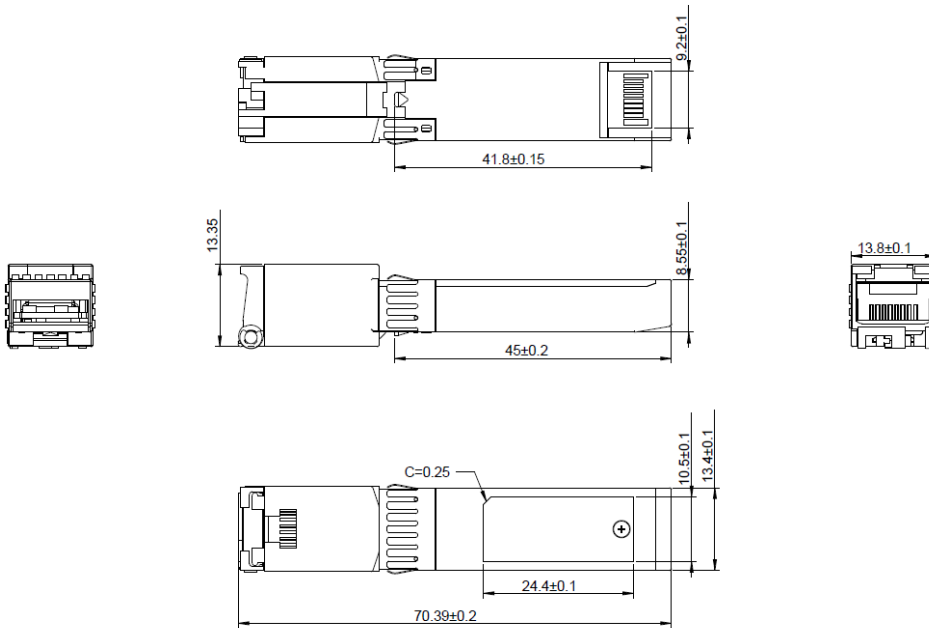

ALL DIMENSIONS ARE  $\pm 0.2$ mm UNLESS OTHERWISE SPECIFIED  
UNIT: mm

## Electrical Pad Layout

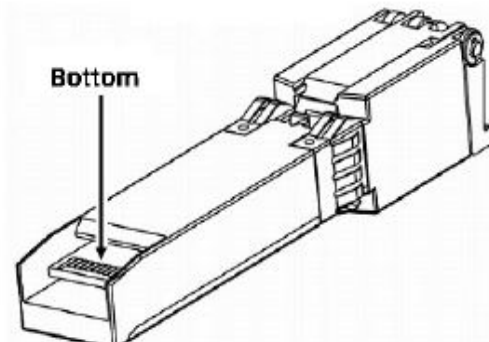
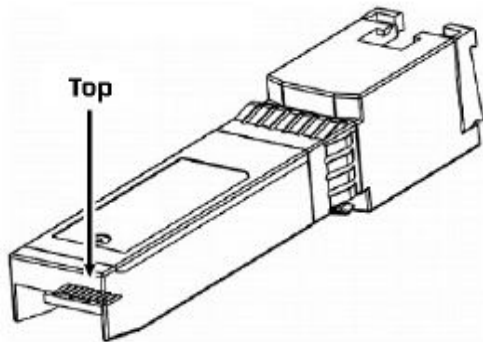
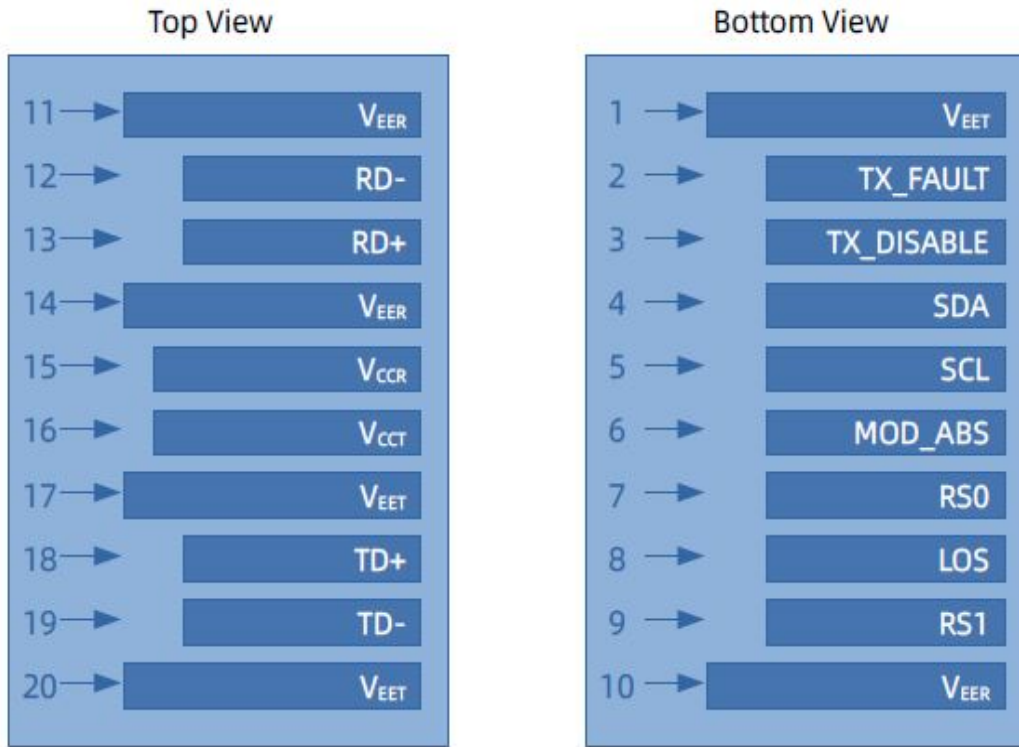

## Pin Assignment

PIN #	Symbol	Description	Remarks
1	V <sub>EET</sub>	Transmitter ground (common with receiver ground)	1
2	TX_FAULT	Transmitter Fault. Not supported	
3	TX_DISABLE	Transmitter Disable. PHY disabled on high or open	2
4	MOD_DEF(2)	Module Definition 2. Data line for serial ID	3
5	MOD_DEF(1)	Module Definition 1. Clock line for serial ID	3
6	MOD_DEF(0)	Module Definition 0. Grounded within the module	3
7	Rate Select	No connection required	
8	LOS	Loss of Signal	
9	V <sub>EER</sub>	Receiver ground (common with transmitter ground)	1
10	V <sub>EER</sub>	Receiver ground (common with transmitter ground)	1
11	V <sub>EER</sub>	Receiver ground (common with transmitter ground)	1
12	RD-	Receiver Inverted DATA out. AC coupled	
13	RD+	Receiver Non-inverted DATA out. AC coupled	
14	V <sub>EER</sub>	Receiver ground (common with transmitter ground)	1
15	V <sub>CCR</sub>	Receiver power supply	
16	V <sub>CCT</sub>	Transmitter power supply	
17	V <sub>EET</sub>	Transmitter ground (common with receiver ground)	1
18	TD+	Transmitter Non-Inverted DATA in. AC coupled	
19	TD-	Transmitter Inverted DATA in. AC coupled	
20	V <sub>EET</sub>	Transmitter ground (common with receiver ground)	1

### Notes:

1. Circuit ground is connected to chassis ground
2. Disabled: T<sub>DIS</sub>>2V or open, Enabled: T<sub>DIS</sub><0.8V
3. Should Be pulled up with 4.7k -10k ohm on host board to a voltage between 2V and 3.6V

## References

1. IEEE standard 802.3. IEEE Standard Department,2005.