

## DATA SHEET

### MODULETEK: SFP-GE-CWDM-xxxx-26DB-C-E10

1.25Gb/s SFP (Small Form Pluggable) CWDM (1270nm - 1610nm) Transceiver

### Overview

ModuleTek's SFP-GE-CWDM-xxxx-26DB-C-E10 SFP optical transceivers are designed for Gigabit Ethernet and Fibre Channel network equipment, they are available in 18 different CWDM wavelengths, from 1270nm to 1610nm. The product implements digital diagnostics via a 2-wire serial bus, compliant with the INF-8074i Small Form Factor Pluggable Multi-Source Agreement (MSA) and SFF-8472 standard.

### Product Features

- Up to 1.25 Gb/s bi-directional data links
- Compliant with IEEE 802.3 Gigabit Ethernet standard
- Compliant with Fiber Channel 100-SM-LL-V standard
- Industry standard small form pluggable (SFP) package
- Compliant with SFP MSA
- Hot-pluggable SFP footprint
- Uncooled DFB laser transmitter in 18 CWDM wavelengths
- Receiver with PIN
- Duplex LC connector
- Built-in digital diagnostic functions
- Single power supply 3.3V
- RoHS Compliant
- Class 1 laser product complies with EN 60825-1
- Operating temperature range:  
Commercial Level: 0°C to 70°C



### Applications

- 1.25Gb/s Gigabit Ethernet
- 1.063Gb/s Fiber Channel

## Ordering Information

Part Number	Product ID	Description	Color on Clasp
SFP-GE-CWDM-1270-26DB-C-E10	M317802W1270	GE/FC SFP CWDM 1270nm The link budget is 26dB, Commercial temperature	Light purple
SFP-GE-CWDM-1290-26DB-C-E10	M317802W1290	GE/FC SFP CWDM 1290nm The link budget is 26dB, Commercial temperature	sky blue
SFP-GE-CWDM-1310-26DB-C-E10	M317802W1310	GE/FC SFP CWDM 1310nm The link budget is 26dB, Commercial temperature	Yellow green
SFP-GE-CWDM-1330-26DB-C-E10	M317802W1330	GE/FC SFP CWDM 1330nm The link budget is 26dB, Commercial temperature	Yellow ocher
SFP-GE-CWDM-1350-26DB-C-E10	M317802W1350	GE/FC SFP CWDM 1350nm The link budget is 26dB, Commercial temperature	Pink
SFP-GE-CWDM-1370-26DB-C-E10	M317802W1370	GE/FC SFP CWDM 1370nm The link budget is 26dB, Commercial temperature	Beige
SFP-GE-CWDM-1390-26DB-C-E10	M317802W1390	GE/FC SFP CWDM 1390nm The link budget is 26dB, Commercial temperature	White
SFP-GE-CWDM-1410-26DB-C-E10	M317802W1410	GE/FC SFP CWDM 1410nm The link budget is 26dB, Commercial temperature	Silver
SFP-GE-CWDM-1430-26DB-C-E10	M317802W1430	GE/FC SFP CWDM 1430nm The link budget is 26dB, Commercial temperature	Black
SFP-GE-CWDM-1450-26DB-C-E10	M317802W1450	GE/FC SFP CWDM 1450nm The link budget is 26dB, Commercial temperature	Yellow orange
SFP-GE-CWDM-1470-26DB-C-E10	M317802W1470	GE/FC SFP CWDM 1470nm The link budget is 26dB, Commercial temperature	Gray
SFP-GE-CWDM-1490-26DB-C-E10	M317802W1490	GE/FC SFP CWDM 1490nm The link budget is 26dB, Commercial temperature	Purple
SFP-GE-CWDM-1510-26DB-C-E10	M317802W1510	GE/FC SFP CWDM 1510nm The link budget is 26dB, Commercial temperature	Blue
SFP-GE-CWDM-1530-26DB-C-E10	M317802W1530	GE/FC SFP CWDM 1530nm The link budget is 26dB, Commercial temperature	Green

SFP-GE-CWDM-1550-26DB-C-E10	M317802W1550	GE/FC SFP CWDM 1550nm The link budget is 26dB, Commercial temperature	Yellow
SFP-GE-CWDM-1570-26DB-C-E10	M317802W1570	GE/FC SFP CWDM 1570nm The link budget is 26dB, Commercial temperature	Orange
SFP-GE-CWDM-1590-26DB-C-E10	M317802W1590	GE/FC SFP CWDM 1590nm The link budget is 26dB, Commercial temperature	Red
SFP-GE-CWDM-1610-26DB-C-E10	M317802W1610	GE/FC SFP CWDM 1610nm The link budget is 26dB, Commercial temperature	Brown
<b>For More Information:</b> ModuleTek Limited Web: <a href="http://www.moduletek.com">www.moduletek.com</a> Email: sales@moduletek.com			

## General Specifications

Parameter	Symbol	Min	Typ	Max	Unit	Remarks
Data Rate	DR	0.622		1.25	Gb/s	
Bit Error Rate	BER			$10^{-12}$		
Operating Temperature	T <sub>C</sub>	0		70	°C	1
Storage Temperature	T <sub>STO</sub>	-40		85	°C	2
Supply Current	I <sub>CC</sub>		200	300	mA	3
Input Voltage	V <sub>CC</sub>	3.14	3.3	3.46	V	
Maximum Voltage	V <sub>MAX</sub>	-0.5		4	V	3

**Notes:**

1. Case temperature
2. Ambient temperature
3. For electrical power interface

## Transmission distance

Data Rate	Wavelength Range	Optical Fiber Type	Distance range (km)
1.25Gb/s	1270nm to 1370nm	9/125um Singel mode fiber	65km
1.25Gb/s	1390nm to 1610nm	9/125um Singel mode fiber	80km

## Optical - Characteristics - Transmitter

$V_{CC}=3.14V$  to  $3.46V$ ,  $T_C$

Parameter	Symbol	Min	Typ	Max	Unit	Remarks
Output Optical Power	$P_{TX}$	0		5	dBm	1
Optical Center Wavelength –1290nm	$\lambda_C$	1284.5	1291	1297.5	nm	
Optical Center Wavelength –1310nm	$\lambda_C$	1304.5	1311	1317.5	nm	
Optical Center Wavelength –1330nm	$\lambda_C$	1324.5	1331	1337.5	nm	
Optical Center Wavelength –1350nm	$\lambda_C$	1344.5	1351	1357.5	nm	
Optical Center Wavelength –1370nm	$\lambda_C$	1364.5	1371	1377.5	nm	
Optical Center Wavelength –1390nm	$\lambda_C$	1384.5	1391	1397.5	nm	
Optical Center Wavelength –1410nm	$\lambda_C$	1404.5	1411	1417.5	nm	
Optical Center Wavelength –1430nm	$\lambda_C$	1424.5	1431	1437.5	nm	
Optical Center Wavelength –1450nm	$\lambda_C$	1444.5	1451	1457.5	nm	
Optical Center Wavelength –1470nm	$\lambda_C$	1464.5	1471	1477.5	nm	
Optical Center Wavelength –1490nm	$\lambda_C$	1484.5	1491	1497.5	nm	
Optical Center Wavelength –1510nm	$\lambda_C$	1504.5	1511	1517.5	nm	
Optical Center Wavelength –1530nm	$\lambda_C$	1524.5	1531	1537.5	nm	
Optical Center Wavelength –1550nm	$\lambda_C$	1544.5	1551	1557.5	nm	
Optical Center Wavelength –1570nm	$\lambda_C$	1564.5	1571	1577.5	nm	
Optical Center Wavelength –1590nm	$\lambda_C$	1584.5	1591	1597.5	nm	
Optical Center Wavelength –1610nm	$\lambda_C$	1604.5	1611	1617.5	nm	
Extinction Ratio	ER	7.5			dB	
Side Mode Suppression Ratio	SMSR	30			dB	
Spectral Width (-20dB)	$\Delta\lambda$			1	nm	
Optical Rise/Fall Time (20%-80%)	$t_r / t_f$			300	ps	

**Notes:**

1. Class 1 Product

## Typical Eye Diagram

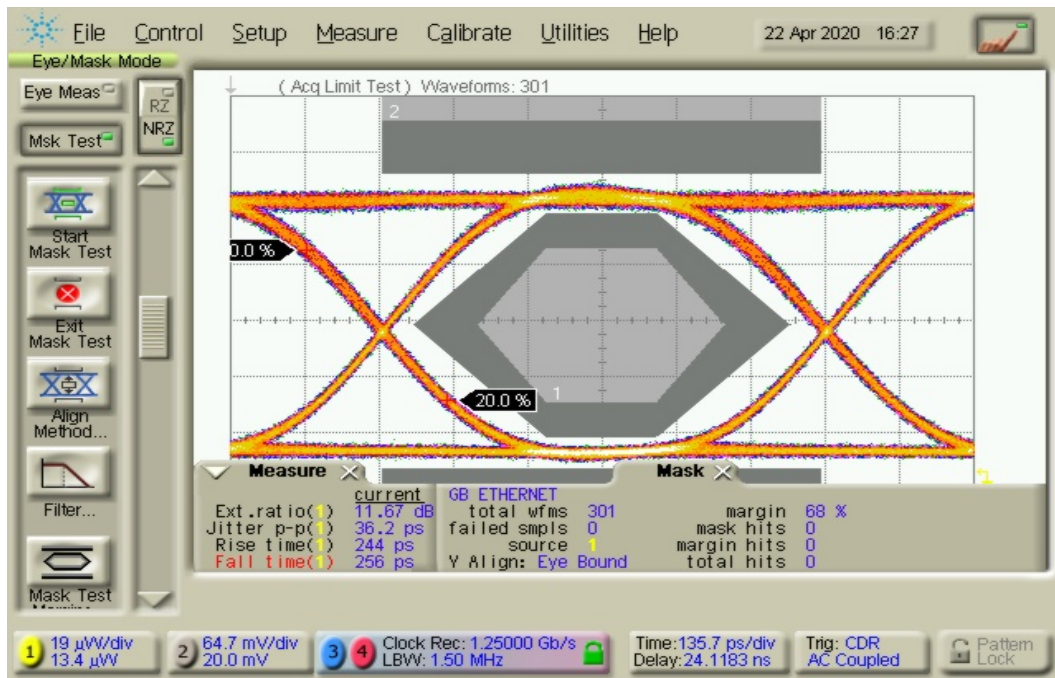

Data pattern: 1.25Gb/s, PRBS 2<sup>7</sup>-1

## Optical - Characteristics - Receiver

$V_{CC}=3.14V$  to  $3.46V$ ,  $T_C=0^{\circ}C$  to  $70^{\circ}C$

Parameter	Symbol	Min	Typ	Max	Unit	Remarks
Receiver Overload	$P_{OL}$	0			dBm	
Optical Center Wavelength	$\lambda_C$	1260		1620	nm	
Receiver Sensitivity @ 1.25Gb/s	$R_{X\_SEN}$			-26	dBm	1
LOS Assert	$LOS_A$	-35			dBm	
LOS De-Assert	$LOS_D$			-26	dBm	
LOS Hysteresis	$LOS_H$		1		dB	

### Notes:

1. Measured with a 2<sup>7</sup>-1 test pattern, @1.25Gb/s, BER<10<sup>-12</sup>

## Electrical - Characteristics - Transmitter

$V_{CC}=3.14V$  to  $3.46V$ ,  $T_C=0^{\circ}C$  to  $70^{\circ}C$

Parameter	Symbol	Min	Typ	Max	Unit	Remarks
Input differential impedance	$R_{IN}$		100		$\Omega$	1
Single ended data input swing	$V_{IN\_PP}$	250		1200	mV	
Transmit disable voltage	$V_D$	$V_{CC}-1.3$		$V_{CC}$	V	
Transmit enable voltage	$V_{EN}$	$V_{EE}$		$V_{EE}+0.8$	V	
Transmit disable assert time				10	$\mu S$	

## Electrical - Characteristics - Receiver

$V_{CC}=3.14V$  to  $3.46V$ ,  $T_C=0^{\circ}C$  to  $70^{\circ}C$

Parameter	Symbol	Min	Typ	Max	Unit	Remarks
Single ended data output swing	$V_{OUT\_PP}$	250		800	mV	
Data output rise/fall time (20%-80%)	$t_r/t_f$		100	175	ps	
LOS Assert	$V_{LOS\_A}$	$V_{CC}-0.5$		$V_{CC\_HOST}$	V	
LOS De-Assert	$V_{LOS\_D}$	$V_{EE}$		$V_{EE}+0.5$	V	
<b>RX Squelch</b>	<b>Method of RX squelch implemented</b>				<b>Remarks</b>	
Not implemented	N.A					

## A0H Device register description

IIC Site	Byte size	Register name	Register description	Value(HEX)
0	1	Identifier	SFP	03
1	1	Extended Identifier	Use the IIC interface	04
2	1	Connector	Use the LC connector	07
3-10	8	Transceiver	1000 Base LX	00 00 00 02 00 00 01 01
11	1	Encoding	Use the 8B/10B coding scheme	01
12	1	BR, Nominal	1.25Gb/s nominal rate	0D
13	1	Rate Identifier	No rate selection	00
14	1	Length(9μm)-km	In single-mode fiber transmission 120km	78
15	1	Length (9μm)-100m	In single-mode fiber transmission 120km	FF
16	1	Length (50μm)-10m	The transmission distance in the multimode fiber	00
17	1	Length (62.5μm)-10m	The transmission distance in the multimode fiber	00
18	1	Length (Copper)	The transmission distance over the copper cable	00
19	1	Reserved	Undefined	00
20-35	16	Trade name	MODULETEK	ASCII Format
36	1	Transceiver	Undefined	00
37-39	3	Vendor OUI	Vendor IEEE company ID	00 00 00
40-55	16	Vendor PN	Vendor's product model	Vendor defined
56-59	4	Vendor Revision Number	Vendor's product version number	Vendor defined
60-61	2	Wavelength	According to the actual wavelength of the laser	According to the actual wavelength of the laser
62	1	Reserved	Undefined	00
63	1	CC_BASE	0-62 Check and of bytes	Vendor defined
64-65	2	Transceiver Options	1.Rx_LOS monitoring 2.Tx_FAULT monitoring 3.Tx_DIS monitoring	00 1A

66	1	BR, max	High bit rate margin	00
67	1	BR, min	Low bit rate margin	00
68-83	16	Vendor SN	Vendor serial number	Vendor defined
84-91	8	Date code	The date code	Vendor defined
92	1	Monitoring Type	DOM Information internal calibration	68
93	1	Enhanced Options	1.Emitting and receiving light alarm and warning monitoring 2.Tx_DIS Sigal monitoring and control 3.Rx_LOS Sigal monitoring 4.Tx_FAULT monitoring	F0
94	1	Compliance	As defined in SFF-8472 in version 12.0	08
95	1	CC_EXT	64-94 Check and bytes	Vendor defined
96-127	32	Vendor Specific	Vendor custom areas	Vendor defined
128-255	128	Vendor Specific	Vendor custom areas	Vendor defined

## Digital Diagnostic Functions

SFP-GE-CWDM-xxxx-26DB-C-E10 supports the 2-wire serial communication protocol as defined in SFP MSA. Digital diagnostic information is accessible over the 2-wire interface at the address 0xA2. Digital diagnostics for SFP-GE-CWDM-xxxx-26DB-C-E10 are internally calibrated by default. The internal micro control unit accesses the device operating parameters in real time, Such as transceiver temperature, laser bias current, transmitted optical power, received optical power and transceiver supply voltage. The module implements the alarm function of the SFP MSA, alerts the user when a particular operating parameter exceeds the factory-set nor-mal range.

## DDM Threshold Information

Parameter	Alarm Threshold		Warning Threshold	
	High Value	Low Value	High Value	Low Value
Temperature (°C)	75 (4B 00)	-5 (FB 00)	70 (46 00)	0(00 00)
Voltage (V)	3.63(8D CC)	2.97 (74 04)	3.46 (87 28)	3.13 (7A 44)
Bias Current (mA)	100 (C3 50)	2 (03 E8)	80 (9C 40)	4 (07 D0)
Tx Power (dBm)	3.79 (5D 87)	-2.97 (13 B7)	3.00 (4D F0)	-2.00 (18 A5)
Rx Power (dBm)	3.01 (4E 20)	-30.46 (00 09)	0.00 (27 10)	-27.21 (00 13)

Parameter	Symbol	Accuracy	Units	Report Range	Unit	Remarks
<b>Internal Calibration</b>						
Temperature	Temp	±5	°C	-40	95	°C
Voltage	V <sub>CC</sub>	±0.1	V	2.7	3.9	V
Bias Current	I <sub>bias</sub>	±10	%	1	80	mA
Tx Power	P <sub>TX</sub>	±3	dB	-5	5	dBm
Rx Power	P <sub>RX</sub>	±3	dB	-35	-5	dBm

## Block-Diagram-of-Transceiver

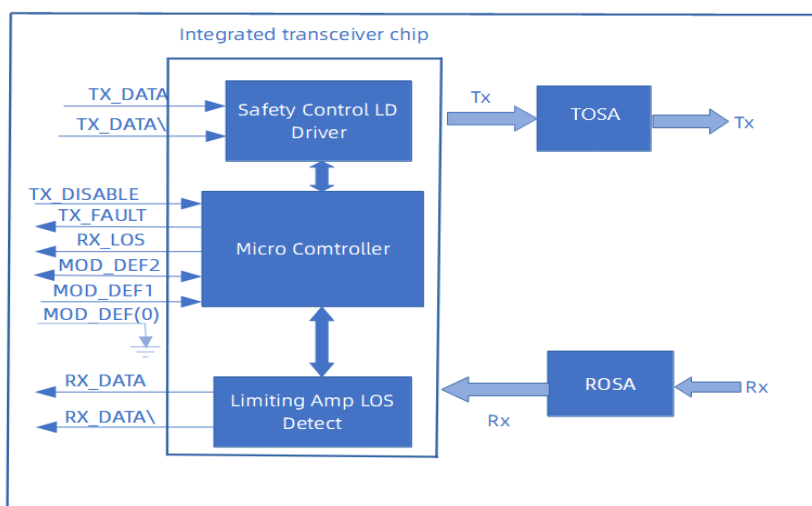

## Functions Description

The transmitter is mainly composed of a laser driver part of the intelligent transceiver chip and a TOSA (light-emitting component). The TOSA includes a DFB laser and a backlight photodetection chip. When the module is working, the input signal is connected to the intelligent transceiver chip, at this time, the laser driver of the intelligent transceiver chip supplies the bias current

and the modulation current to the laser. The intelligent transceiver chip simultaneously uses an automatic optical power control (APC) feedback loop to maintain a constant average optical power of the laser output. The purpose is to eliminate the change of the output optical signal due to temperature changes and aging of the light source device. When the transmitter enable pin (TX\_Disable) is high (TTL logic "1"), the laser output is turned off. When TX\_Disable is low (TTL logic "0"), the laser will turn on within 1ms. When the transmitter fault signal (TX\_Fault) is reported as high, indicates a transmitter failure caused by the transmitter's bias current or transmitted optical power or laser tube temperature exceeding a preset alarm threshold. Low indicates normal operation.

The receiver is mainly composed of a limiting amplifier part of the intelligent transceiver chip and a ROSA (light-receiving component). The ROSA includes a PIN photodetector and a transimpedance amplifier chip. When the ROSA detects the incident light signal, it will be converted into a photo-generated current by the PIN photodetector. The photo-generated current is converted into an electrical signal after passing through the transimpedance amplifier. The electrical signal is further amplified by the limiting amplifier, then outputs a fixed-amplitude electrical signal to the host. When the amplitude of the electrical signal received from the incident light conversion of the opposite optical transceiver module is lower than the set threshold, the module reports that the received signal is lost, the RX\_LOS pin is high (logic "1"), which can be used to diagnose whether the physical signal is normal. The signal is operated in TTL level. The microprocessor inside the module monitors the module's operating voltage, temperature, transmitted optical power, received optical power, and laser bias current value in real time. The host acquires this information over a 2-wire serial bus.

The implemented method of RX\_LOS is OMA(optical modulation amplitude).

## A0h/A2h Write Protection

Security Level 1 Password :

Password Entry ADDR	Size	Vaules(hex)	Remark
Page A2h,7Bh-7Eh	4	12 34 56 78	

After the module is powered on, the read value of the security level access registers 0x7Bh to 0x7Eh of A2h is replaced with 0xFFh.

After entering the security level 1 working state, the user can directly write to the contents of the A0h device address and Table 00h and Table 01h of A2h device address.

## Product weight

The module of weight:17.0 Grams of each

Dust cap weight:0.95 Grams of each

## Dimensions

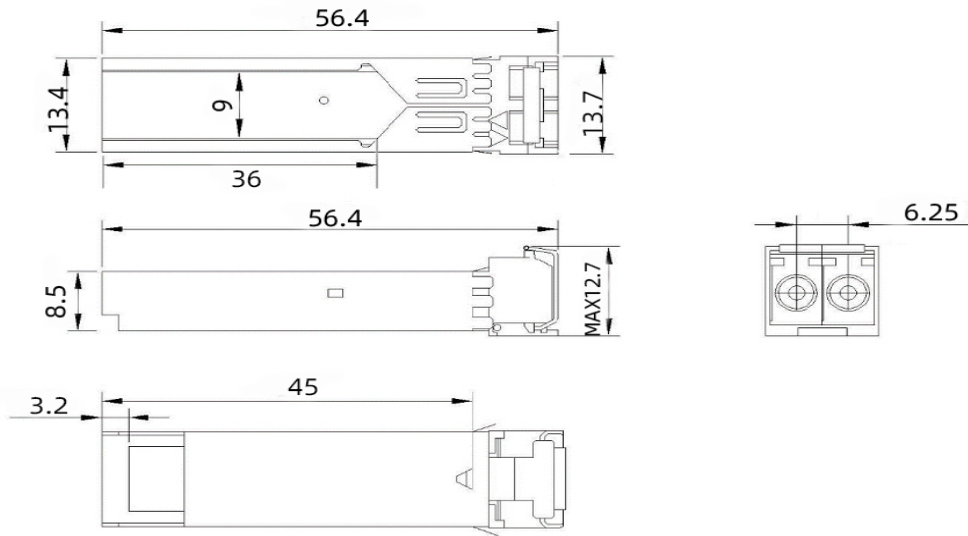

ALL DIMENSIONS ARE  $\pm 0.2$ mm UNLESS OTHERWISE SPECIFIED  
UNIT: mm

## Electrical Pad Layout



Top of Board



Bottom of Board

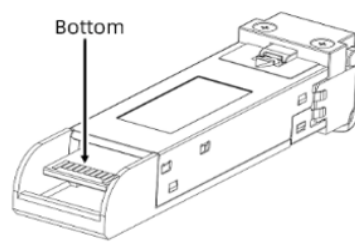
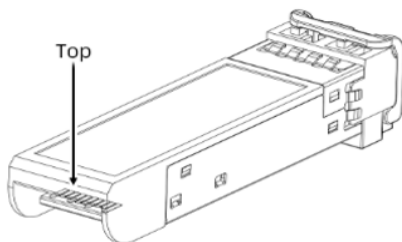

## Pin Assignment

PIN #	Symbol	Description	Remarks
1	V <sub>EET</sub>	Transmitter ground (common with receiver ground)	1
2	TX_FAULT	Transmitter Fault. Not supported	
3	TX_DISABLE	Transmitter Disable. Laser output disabled on high or open	2
4	MOD_DEF(2)	Module Definition 2. Data line for serial ID	3
5	MOD_DEF(1)	Module Definition 1. Clock line for serial ID	3
6	MOD_DEF(0)	Module Definition 0. Grounded within the module	3
7	Rate Select	No connection required	
8	LOS	Loss of Signal indication. Logic 0 indicates normal operation	4
9	V <sub>EER</sub>	Receiver ground (common with transmitter ground)	1
10	V <sub>EER</sub>	Receiver ground (common with transmitter ground)	1
11	V <sub>EER</sub>	Receiver ground (common with transmitter ground)	1
12	RD-	Receiver Inverted DATA out. AC coupled	
13	RD+	Receiver Non-inverted DATA out. AC coupled	
14	V <sub>EER</sub>	Receiver ground (common with transmitter ground)	1
15	V <sub>CCR</sub>	Receiver power supply	
16	V <sub>CCT</sub>	Transmitter power supply	
17	V <sub>EET</sub>	Transmitter ground (common with receiver ground)	1
18	TD+	Transmitter Non-Inverted DATA in. AC coupled	
19	TD-	Transmitter Inverted DATA in. AC coupled	
20	V <sub>EET</sub>	Transmitter ground (common with receiver ground)	1

### Notes:

1. Circuit ground is isolated from chassis ground
2. Disabled: T<sub>DIS</sub>>2V or open, Enabled: T<sub>DIS</sub><0.8V
3. Should Be pulled up with 4.7k –10k ohm on host board to a voltage between 2V and 3.6V
4. LOS is open collector output

## References

1. IEEE standard 802.3. IEEE Standard Department, 2002.
2. Small Form Factor Pluggable (SFP) Transceiver Multi-Source Agreement (MSA), INF-8074i.
3. Fiber Channel Draft Physical Interface Specification (FC-PI 10.0).
4. Digital Diagnostics Monitoring Interface for Optical Transceivers –SFF-8472.