

DATA SHEET

MODULETEK: SFP-FE-T-x-D12

100BASE-T SFP (Small Form Pluggable) Copper Transceiver

Overview

ModuleTek's SFP-FE-T copper SFP transceivers are based on Fast Ethernet IEEE 802.3 standard and 100BASE-T standard and provide a quick and reliable interface for the FE application. In addition, they comply with the Small Form Factor Pluggable Multi-Source Agreement (MSA)

Product Features

- Up to 125Mb/s bi-directional data links
- Compliant with SFP MSA
- Hot-pluggable SFP footprint
- Support 100BASE-T full duplex default operating mode
- Support 100BASE-T operation in host systems
- Auto-sense MDI/MDIX
- Single power supply 3.3V
- RoHS Compliant
- Operating temperature range (Case Temperature):
 - Commercial Level: 0°C to 70°C
 - Industrial Level: -40°C to 85°C

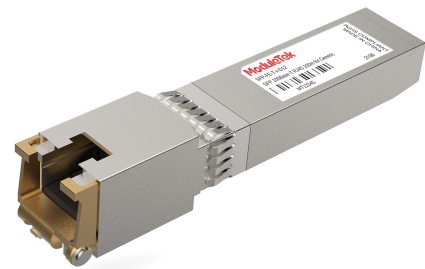

Applications

- 125 Mb/s Fast Ethernet

Ordering Information

Part Number	Product ID	Description	Operating Temperature Range
SFP-FE-T-C-D12	M294402	100BASE-T SFP Copper RJ-45 Connector 100m, commercial temperature	0°C to 70°C
SFP-FE-T-I-D12	M108902	100BASE-T SFP Copper RJ-45 Connector 100m, industrial temperature	-40°C to 85°C
Notes: 1.The product with write protection. 2.Product ID is the short order number of our product standard model.			
For More Information: ModuleTek Limited Web: www.moduletek.com Email: sales@moduletek.com			

General Specifications

Parameter	Symbol	Min	Typ	Max	Unit	Remarks
Data Rate	DR		100		Mb/sec	
Cable Length	CL			100	m	1
Bit Error Rate	BER			10 ⁻¹²		
Operating Temperature	T _C	0		70	°C	2
		-40		85	°C	3
Storage Temperature	T _{STO}	-40		85	°C	4
Supply Current	I _{CC}		190	300	mA	5
Input Voltage	V _{CC}	3.14	3.30	3.46	V	6
Maximum Voltage	V _{MAX}			4	V	5
Surge Current	V _{surge}			30	V	7

Notes:

1. Category 5 UTP
2. Case temperature, commercial temperature
3. Case temperature, industrial temperature
4. Ambient temperature
5. For electrical power interface
6. Referenced to GND. For electrical power interface
7. Hot Plug above steady state current. For electrical power interface

I2C Memory Map

Address A0					
IIC Addr	Size	Name	Description	Values (HEX)	Remarks
0	1	Identifier	SFP or SFP+	03	
1	1	Ext. Identifier	GBIC/SFP function is defined by two-wire interface ID only	04	
2	1	Connector	RJ45 (Registered Jack)	22	
3-10	8	Transceiver	Code for electronic or optical compatibility	00 00 00 20 00 00 00 00	
11	1	Encoding	4B/5B	02	
12	1	BR, Nominal	Nominal Bit Rate 100Mb/s	01	
13	1	Rate Identifier	Type of rate select functionality	00	
14	1	Length(SMF,km)	Link length supported for single mode fiber, units of km	00	
15	1	Length (SMF)	Link length supported for single mode fiber, units of 100 m	00	
16	1	Length (50um)	Link length supported for 50 um OM2 fiber, units of 10 m	00	
17	1	Length (62.5um)	Link length supported for 62.5 um OM1 fiber, units of 10 m	00	
18	1	Length (OM4 or copper cable)	100m	64	
19	1	Length (OM3)	Link length supported for 50 um OM3 fiber, units of 10 m	00	
20-35	16	Vendor name	MODULETEK	4D 4F 44 55 4C 45 54 45 4B 20 20 20 20 20 20 20	
36	1	Transceiver	Code for electronic or optical compatibility	00	
37-39	3	Vendor OUI	SFP vendor IEEE company ID	00 00 00	
40-55	16	Vendor PN	Part number in Order information	-	

56-59	4	Vendor rev	Revision level for part number provided by vendor (ASCII)	-	
60-61	2	Wavelength	Laser wavelength (Passive/Active Cable Specification Compliance)	00 00	
62	1	Unallocated		00	
63	1	CC BASE	Check code for Base ID Fields (addresses 0 to 62)	-	
64-65	2	Options	Indicates which optional transceiver signals are implemented	00 00	
66	1	BR, max	Upper bit rate margin	00	
67	1	BR, min	Lower bit rate margin	00	
68-83	16	Vendor SN	Serial number provided by vendor	Programmed by Factory	
84-91	8	Date code	Year,Month,Day	Programmed by Factory	
92	1	Diagnostic Monitoring Type	Indicates which type of diagnostic monitoring is implemented (if any) in the transceiver	00	
93	1	Enhanced Options	Indicates which optional enhanced features are implemented (if any) in the transceiver	00	
94	1	SFF-8472 Compliance	Indicates which revision of SFF-8472 the transceiver complies with.	00	
95	1	CC EXT	Check code for the Extended ID Fields (addresses 64 to 94)	-	
96-127	32	Vendor Specific	Vendor Specific EEPROM	-	
128-255	128	Vendor Specific	Vendor Specific EEPROM	-	
Address A2 Low (Commercial Temperature Version)					
IIC Addr	Size	Name	Description	Values (HEX)	Remarks
0-1	2	Temp High Alarm	75°C	4B 00	
2-3	2	Temp Low Alarm	-5°C	FB 00	
4-5	2	Temp High Warning	70°C	46 00	
6-7	2	Temp Low Warning	0°C	00 00	

8-9	2	Vcc High Alarm	3.63V	8D CC	
10-11	2	Vcc Low Alarm	2.97V	74 04	
12-13	2	Vcc High Warning	3.46V	87 28	
14-15	2	Vcc Low Warning	3.13V	7A 44	
16-17	2	Bias High Alarm	Bias High Alarm	00 00	
18-19	2	Bias Low Alarm	Bias Low Alarm	00 00	
20-21	2	Bias High Warning	Bias High Warning	00 00	
22-23	2	Bias Low Warning	Bias Low Warning	00 00	
24-25	2	TxPower High Alarm	TxPower High Alarm	00 00	
26-27	2	TxPower Low Alarm	TxPower Low Alarm	00 00	
28-29	2	TxPower High Warning	TxPower High Warning	00 00	
30-31	2	TxPower Low Warning	TxPower Low Warning	00 00	
32-33	2	RxPower High Alarm	RxPower High Alarm	00 00	
34-35	2	RxPower Low Alarm	RxPower Low Alarm	00 00	
36-37	2	RxPower High Warning	RxPower High Warning	00 00	
38-39	2	RxPower Low Warning	RxPower Low Warning	00 00	
40-55	16	Reserved	Reserved	00	
56-59	4	Ext RxPwr 4	Ext RxPwr 4	00 00 00 00	
60-63	4	Ext RxPwr 3	Ext RxPwr 3	00 00 00 00	
64-67	4	Ext RxPwr 2	Ext RxPwr 2	00 00 00 00	
68-71	4	Ext RxPwr 1	Ext RxPwr 1	00 00 00 00	
72-75	4	Ext RxPwr 0	Ext RxPwr 0	00 00 00 00	
76-77	2	Ext Bias Slope	Ext Bias Slope	00 00	
78-79	2	Ext Bias Offset	Ext Bias Offset	00 00	
80-81	2	Ext TxPower Slope	Ext TxPower Slope	00 00	
82-83	2	Ext TxPower Offset	Ext TxPower Offset	00 00	
84-85	2	Ext Temp Slope	Ext Temp Slope	01 00	
86-87	2	Ext Temp Offset	Ext Temp Offset	00 00	
88-89	2	Ext Vcc Slope	Ext Vcc Slope	01 00	

90-91	2	Ext Vcc Offset	Ext Vcc Offset	00 00	
92-94	3	Reserved	Reserved	00	
95	1	Checksum	0-94 Byte Checksum	30	
96-97	2	Temperature	Temperature	-	
98-99	2	Vcc	Vcc	-	
100-101	2	Bias Current	Bias Current	00 00	
102-103	2	Tx Power	Tx Power	00 00	
104-105	2	Rx Power	Rx Power	00 00	
106-109	4	Reserved	Reserved	00 00 00 00	
110	1	Optional Status/Control Bits	02		
111	1	Reserved	Reserved	00	
112-113	2	Alarm Flags	Alarm Flags	00 00	
114-115	2	Reserved	Reserved	00 00	
116-117	2	Warning Flags	Warning Flags	00 00	
118-121	4	Reserved	Reserved	00 00 00 00	
122	1	Security Level	Security Level: 00=Normal Mode; 01=User Mode (Level 1); 02=Factory Mode (Level 2);	00	
123-126	4	Password Entry	Password Entry Area	00 00 00 00	
127	1	Table Selection	Page Select Byte	00	
Address A2 Low (Industrial Temperature Version)					
IIC Addr	Size	Name	Description	Values (HEX)	Remarks
0-1	2	Temp High Alarm	90°C	5A 00	
2-3	2	Temp Low Alarm	-45°C	D3 00	
4-5	2	Temp High Warning	85°C	55 00	
6-7	2	Temp Low Warning	-40°C	D8 00	
8-9	2	Vcc High Alarm	3.63V	8D CC	
10-11	2	Vcc Low Alarm	2.97V	74 04	
12-13	2	Vcc High Warning	3.46V	87 28	
14-15	2	Vcc Low Warning	3.13V	7A 44	
16-17	2	Bias High Alarm	Bias High Alarm	00 00	
18-19	2	Bias Low Alarm	Bias Low Alarm	00 00	

20-21	2	Bias High Warning	Bias High Warning	00 00	
22-23	2	Bias Low Warning	Bias Low Warning	00 00	
24-25	2	TxPower High Alarm	TxPower High Alarm	00 00	
26-27	2	TxPower Low Alarm	TxPower Low Alarm	00 00	
28-29	2	TxPower High Warning	TxPower High Warning	00 00	
30-31	2	TxPower Low Warning	TxPower Low Warning	00 00	
32-33	2	RxPower High Alarm	RxPower High Alarm	00 00	
34-35	2	RxPower Low Alarm	RxPower Low Alarm	00 00	
36-37	2	RxPower High Warning	RxPower High Warning	00 00	
38-39	2	RxPower Low Warning	RxPower Low Warning	00 00	
40-55	16	Reserved	Reserved	00	
56-59	4	Ext RxPwr 4	Ext RxPwr 4	00 00 00 00	
60-63	4	Ext RxPwr 3	Ext RxPwr 3	00 00 00 00	
64-67	4	Ext RxPwr 2	Ext RxPwr 2	00 00 00 00	
68-71	4	Ext RxPwr 1	Ext RxPwr 1	00 00 00 00	
72-75	4	Ext RxPwr 0	Ext RxPwr 0	00 00 00 00	
76-77	2	Ext Bias Slope	Ext Bias Slope	00 00	
78-79	2	Ext Bias Offset	Ext Bias Offset	00 00	
80-81	2	Ext TxPower Slope	Ext TxPower Slope	00 00	
82-83	2	Ext TxPower Offset	Ext TxPower Offset	00 00	
84-85	2	Ext Temp Slope	Ext Temp Slope	01 00	
86-87	2	Ext Temp Offset	Ext Temp Offset	00 00	
88-89	2	Ext Vcc Slope	Ext Vcc Slope	01 00	
90-91	2	Ext Vcc Offset	Ext Vcc Offset	00 00	
92-94	3	Reserved	Reserved	00	
95	1	Checksum	0-94 Byte Checksum	30	
96-97	2	Temperature	Temperature	-	
98-99	2	Vcc	Vcc	-	
100-101	2	Bias Current	Bias Current	00 00	

102-103	2	Tx Power	Tx Power	00 00	
104-105	2	Rx Power	Rx Power	00 00	
106-109	4	Reserved	Reserved	00 00 00 00	
110	1	Optional Status/Control Bits	02		
111	1	Reserved	Reserved	00	
112-113	2	Alarm Flags	Alarm Flags	00 00	
114-115	2	Reserved	Reserved	00 00	
116-117	2	Warning Flags	Warning Flags	00 00	
118-121	4	Reserved	Reserved	00 00 00 00	
122	1	Security Level	Security Level: 00=Normal Mode; 01=User Mode (Level 1); 02=Factory Mode (Level 2);	00	
123-126	4	Password Entry	Password Entry Area	00 00 00 00	
127	1	Table Selection	Page Select Byte	00	
Address A2 Page 00h					
IIC Addr	Size	Name	Description	Values (HEX)	Remarks
128-255	128	Upper Memory Map	User Code Area	-	
Address A2 Page 8Ah					
IIC Addr	Size	Name	Description	Values (HEX)	Remarks
128-131	4	Firmware Version Number[4]	Firmware Version Number	-	
132-135	4	Total Running Time In Second	Total Running Time In Second	-	
Address A2 Page F0h					
IIC Addr	Size	Name	Description	Values (HEX)	Remarks
128-131	4	Password1 Long	Level 1 Password	00 00 10 11	
132	1	Disable A0 WP	00=A0 With Write Protection; 01=A0 Without Write Protection	00	
133	1	Disable A2T00T01 WP	00=A2 T00T01 With Write Protection; 01=A2 T00T01 Without Write Protection	00	

Notes:

1.Password entry area default 00000000, read out as last written value

User Mode

Level 1 Default Password	Password Can Be Changed	Permissions
00 00 10 11	YES(A2 TF0)	1. Read And Write A0
		2. Read And Write A2 T00/T01
		3. Read A2 T8A
		4. Read And Write A2 TF0

Notes:

1.detail in I2C memory map

Dimensions

Weight: 25.0g

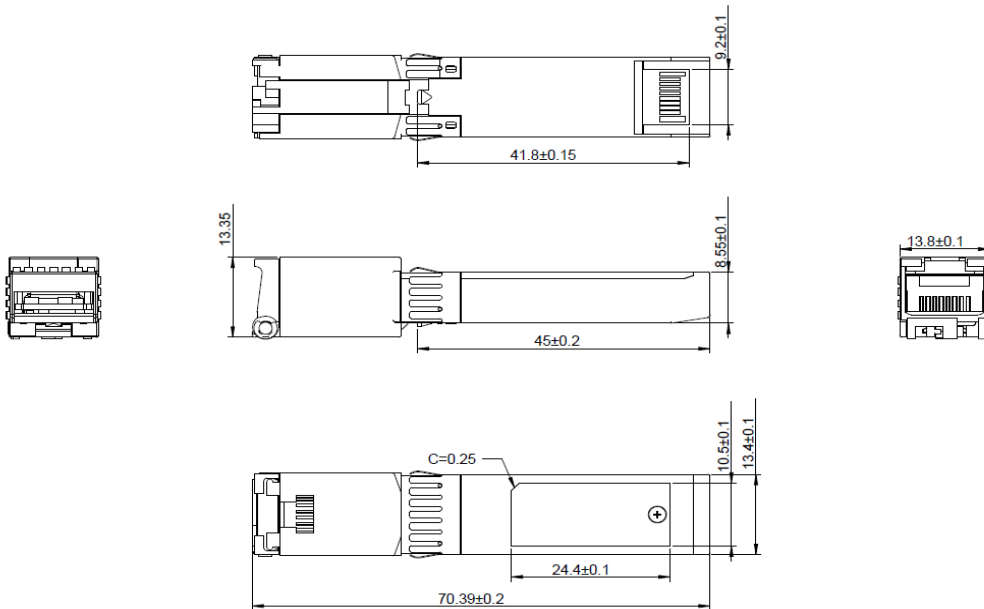

ALL DIMENSIONS ARE ± 0.2 mm UNLESS OTHERWISE SPECIFIED
UNIT: mm

Electrical Pad Layout

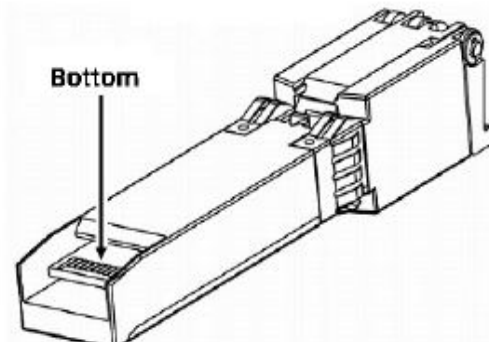
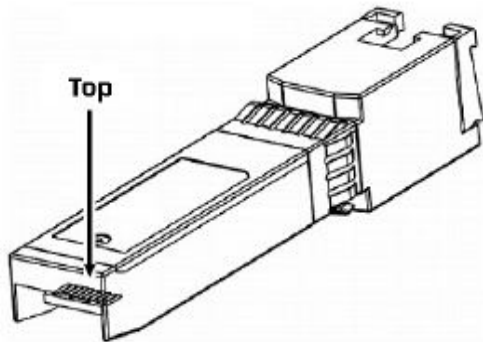
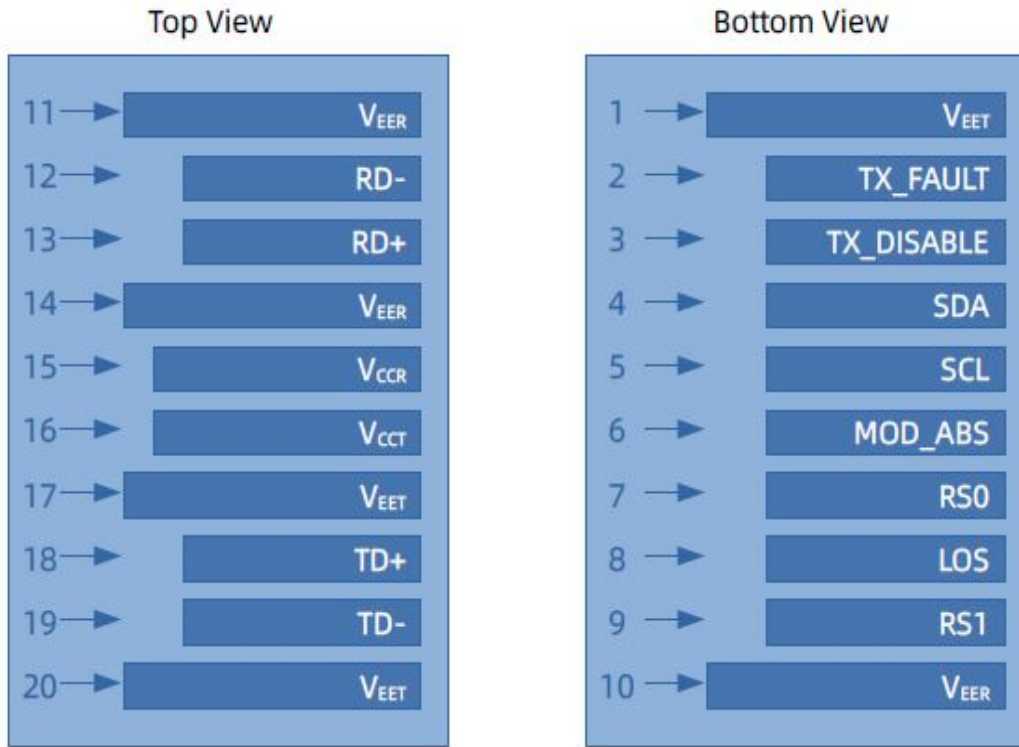

Pin Assignment

PIN #	Symbol	Description	Remarks
1	V _{EET}	Transmitter ground (common with receiver ground)	1
2	TX_FAULT	Transmitter Fault. Not supported	
3	TX_DISABLE	Transmitter Disable. PHY disabled on high or open	2
4	MOD_DEF(2)	Module Definition 2. Data line for serial ID	3
5	MOD_DEF(1)	Module Definition 1. Clock line for serial ID	3
6	MOD_DEF(0)	Module Definition 0. Grounded within the module	3
7	Rate Select	No connection required	
8	LOS	Loss of Signal	
9	V _{EER}	Receiver ground (common with transmitter ground)	1
10	V _{EER}	Receiver ground (common with transmitter ground)	1
11	V _{EER}	Receiver ground (common with transmitter ground)	1
12	RD-	Receiver Inverted DATA out. AC coupled	
13	RD+	Receiver Non-inverted DATA out. AC coupled	
14	V _{EER}	Receiver ground (common with transmitter ground)	1
15	V _{CCR}	Receiver power supply	
16	V _{CCT}	Transmitter power supply	
17	V _{EET}	Transmitter ground (common with receiver ground)	1
18	TD+	Transmitter Non-Inverted DATA in. AC coupled	
19	TD-	Transmitter Inverted DATA in. AC coupled	
20	V _{EET}	Transmitter ground (common with receiver ground)	1

Notes:

1. Circuit ground is connected to chassis ground
2. Disabled: T_{DIS}>2V or open, Enabled: T_{DIS}<0.8V
3. Should Be pulled up with 4.7k -10k ohm on host board to a voltage between 2V and 3.6V

References

1. IEEE standard 802.3. IEEE Standard Department, 2002.
2. Small Form Factor Pluggable (SFP) Transceiver Multi-Source Agreement (MSA), September 2000.