

DATA SHEET

MODULETEK: SFP-25G-ER-x-C10

25Gb/s SFP28 ER 40km Transceiver

SFP-25G-ER-x-C10 Overview

ModuleTek's SFP-25G-ER-x-C10 optical transceivers are based on 25G Ethernet IEEE 802.3 standard. They are compliant with SFF-8432 and SFF-8472, providing a fast and reliable interface for 25G Ethernet applications. The product implements digital diagnostics via a 2-wire serial bus and is compliant with the SFF-8472 standard.

Product Features

- Operating data rate support 25.78Gbps
- EML transmitter and APD photo-detector
- Compliant with IEEE 802.3-2022
- Compliant with SFF-8402 Rev1.2
- Compliant with SFF-8432 Rev5.2a
- Compliant with SFF-8472 Rev12.3
- Internal CDR on both Transmitter and Receiver channel
- Hot-pluggable SFP28 footprint
- Duplex LC connector
- Built-in digital diagnostic functions
- Up to 40km on SMF
- Single power supply 3.3V
- RoHS Compliant
- Operating temperature range (Case Temperature): Commercial Level: 0°C to 70°C
Industrial Level: -40°C to 85°C

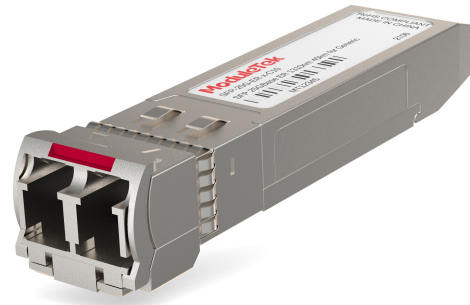

Applications

- 25G Ethernet

Ordering Information

Part Number	Product ID	Description	Bail Color
SFP-25G-ER-C-C10	M008200	25GBASE ER, LC Connectors 40km on SMF, Commercial Temperature	Red
SFP-25G-ER-I-C10	M008201	25GBASE ER, LC Connectors 40km on SMF, Industrial Temperature	Red
Notes: 1.Product ID is the abbreviated order number of the standard model of our products			
For More Information: ModuleTek Limited Web: www.moduletek.com Email: sales@moduletek.com			

General Specifications

Parameter	Symbol	Min	Typ	Max	Unit	Remarks
Data Rate	DR		25.78		Gb/s	1
Bit Error Rate	BER			5×10^{-5}		2
Operating Temperature	T_C	0		70	°C	3
		-40		85	°C	3
Storage Temperature	T_{STO}	-40		85	°C	4
Supply Current (Commercial Temperature)	I_{CC}			450	mA	
Supply Current (Industrial Temperature)	I_{CC}			550	mA	
Input Voltage	V_{CC}	3.14	3.3	3.46	V	
Power Consumption (Commercial Temperature)	P			1.5	W	
Power Consumption (Industrial Temperature)	P			1.8	W	
Maximum Voltage	V_{MAX}	0		3.6	V	5

Notes:

1. IEEE 802.3
2. Measured with data rate at 25.78Gb/s, PRBS $2^{31} - 1$
3. Case temperature
4. Ambient temperature
5. For electrical power interface

Link Distances

Data Rate	Fiber Type	Distance Range (km)	Remarks
25.78 Gb/s	9/125um SMF	40	1

Notes:

1. This module requires RS-FEC on the host ports for operation at 25G

Optical Characteristics - Transmitter

V_{CC}=3.14V to 3.46V, T_C

Parameter	Symbol	Min	Typ	Max	Unit	Remarks
Output Optical Power	P _{TX}	-3		6	dBm	1
Optical Center Wavelength	λ _C	1295		1310	nm	
Extinction Ratio	ER	4			dB	
Spectral Width (-20dB)	Δλ			1	nm	
Side Mode Suppression Ratio	SMSR	30			dB	
Launch Power of OFF Transmitter	P _{OUT_OFF}			-30	dBm	1

Notes:

1. Average

Optical - Characteristics - Receiver

V_{CC}=3.14V to 3.46V, T_C

Parameter	Symbol	Min	Typ	Max	Unit	Remarks
Optical Center Wavelength	λ _C	1295		1325	nm	
Receive Overload	P _{OL}	-4			dBm	
Receiver Sensitivity	R _{X_SEN}			-21	dBm	1
LOS Assert	LOS _A	-30			dBm	
LOS De-Assert	LOS _D			-22	dBm	
LOS Hysteresis	LOS _H	0.5			dB	

Notes:

1. Average optical power, under the condition of measuring signal ER = 9dB, rate = 25.78Gb/s and PRB S_{2³¹-1}

Electrical Characteristics - Transmitter

$V_{CC}=3.14V$ to $3.46V, T_C$

Parameter	Symbol	Min	Typ	Max	Unit	Remarks
Input differential impedance	R_{IN}		100		Ω	
Differential data input swing	V_{IN_PP}	180		700	mV	
Transmit Disable Voltage	V_D	2		V_{CC}	V	
Transmit Enable Voltage	V_{EN}	V_{EE}		$V_{EE}+0.8$	V	

Electrical - Characteristics - Receiver

$V_{CC}=3.14V$ to $3.46V, T_C$

Parameter	Symbol	Min	Typ	Max	Unit	Remarks
Differential data output swing	V_{OUT_PP}	150		900	mV	
LOS Assert	V_{LOS_A}	2		V_{CC_HOST}	V	
LOS De-Assert	V_{LOS_D}	V_{EE}		$V_{EE}+0.8$	V	

IIC Memory Map(Page A0 HEX, Unlisted Fields are Blank/Empty)

IIC Addr	Size	Name	Description	Default Power On Values(HEX)
0	1	Identifier	SFP/SFP+/SFP28	03
1	1	Extended Identifier	Use IIC interface	04
2	1	Connector	Connector Type = LC	07
3-10	8	Transceiver	25G Base ER	00 00 00 00 00 00 00 00
11	1	Encoding	Encoding Type = 64B/66B	06
12	1	BR, Nominal	Nominal Bit Rate 25.78Gb/s	FF
13	1	Rate Identifier	Without rate selection function	00
14	1	Length(9μm)-km	Link Length / SMF = 40km	28
15	1	Length (9μm)-100m	Link Length / SMF = 40km	FF
16	1	Length (50μm)-10m	50μm MMF Link Length = N/A	00
17	1	Length (62.5μm)-10m	62.5μm MMF Link Length = N/A	00
18	1	Length (Copper)	Copper Link Length = N/A	00
19	1	Reserved	Reserved	00
20-35	16	Vendor name	MODULETEK	4D 4F 44 55 4C 45 54 45 4B 20 20 20 20 20 20 20
36	1	Transceiver	25G Base ER	04
37-39	3	Vendor OUI	Without vendor OUI	00 00 00
40-55	16	Vendor PN	Part number in the Ordering Information	Defined by the vendor
56-59	4	Vendor Revision Number	Manufacturer product version number	Defined by the vendor
60-61	2	Wavelength	Laser Wavelength, 1310	05 1E
62	1	Reserved	Reserved	00
63	1	CC_BASE	Checksum of bytes 0-62	Defined by the vendor

64	1	Transceiver Options	<p>BIT7=0 Reserved</p> <p>BIT6 Power Level Declaration</p> <p>BIT5 Power Level Declaration</p> <p>BIT4=1 Paging implemented function</p> <p>BIT3=1 Retimer or CDR indicator</p> <p>BIT2=1 A cooled laser transmitter implementation</p> <p>BIT1 Power Level Declaration</p> <p>BIT0=0 A conventional limiting receiver output</p> <p>Commercial Temperature: Power Level 2(<1.5W, BIT6=0, BIT5=0, BIT1=1)</p> <p>Industrial Temperature: Power Level 3(<2.0W, BIT6=0, BIT5=1, BIT1=0)</p>	1E/3C
65	1	Transceiver Options	<p>BIT7=0 Receiver decision threshold implemented is not realized</p> <p>BIT6=0 Tunable wavelength lasers are not used</p> <p>BIT5=1 RATE_SELECT functionality is not realized</p> <p>BIT4=1 TX_DISABLE is implemented</p> <p>BIT3=1 TX_FAULT signal implemented</p> <p>BIT2=0 Loss of Signal is not realized, signal inverted from standard definition in SFP MSA (often called "Signal Detect")</p> <p>BIT1=1 Loss of Signal implemented, signal as defined in SFP MSA</p> <p>BIT0=0 Reserved</p>	1A
66	1	BR,max	Maximum signal rate	67
67	1	BR, min	Maximum signal rate deviation	00
68-83	16	Vendor SN	Manufacturer serial number	Defined by the vendor
84-91	8	Date code	Date code	Defined by the vendor
92	1	Diagnostic Monitoring Type	<p>BIT7=0 Compatible with SFF-8472 requirements</p> <p>BIT6=1 Realize digital diagnostic function</p> <p>BIT5=1 Internal calibration is implemented</p> <p>BIT4=0 Externally calibration is not realized</p> <p>BIT3=1 Received power is the averaged power</p> <p>BIT2=0 Don't need address change</p> <p>BIT1=0 Reserved</p> <p>BIT0=0 Reserved</p>	68

93	1	Enhanced Options	<p>BIT7=1 Optional Alarm/warning flags implemented for all monitored quantities</p> <p>BIT6=1 Optional soft TX_DISABLE control and monitoring implemented</p> <p>BIT5=1 Optional soft TX_FAULT monitoring implemented</p> <p>BIT4=1 Optional soft RX_LOS monitoring implemented</p> <p>BIT3=0 Optional soft RATE_SELECT control and monitoring is not realized</p> <p>BIT2=0 The optional soft rate selection control function is not implemented by SFF-8079</p> <p>BIT1=0 The optional soft rate selection control function is not implemented by SFF-8431</p> <p>BIT0=0 Reserved</p>	F0
94	1	Compliance	Includes functionality described in Rev 12.3 of SFF-8472	08
95	1	CC_EXT	Check sum of bytes 64-94	Defined by the vendor
96-127	32	Vendor Specific	Vendor specific memory addresses	Defined by the vendor
128-255	128	Vendor Specific	Vendor specific memory addresses	Defined by the vendor

IIC Memory Map(Page A2 HEX LOW, Unlisted Fields are Blank/Empty)

IIC ADDR	Size	Name	Description	Default Power On Values(HEX)
Alarm/Warning Thresholds				
00-01	2	Temp High Alarm	Temperature high alarm	See Table Of Threshold Ranges
02-03	2	Temp Low Alarm	Temperature low alarm	See Table Of Threshold Ranges
04-05	2	Temp High Warning	Temperature high warning	See Table Of Threshold Ranges
06-07	2	Temp Low Warning	Temperature low warning	See Table Of Threshold Ranges
08-09	2	Voltage High Alarm	Voltage high alarm	See Table Of Threshold Ranges
10-11	2	Voltage Low Alarm	Voltage low alarm	See Table Of Threshold Ranges
12-13	2	Voltage High Warning	Voltage high warning	See Table Of Threshold Ranges
14-15	2	Voltage Low Warning	Voltage low warning	See Table Of Threshold Ranges
16-17	2	Bias High Alarm	Bias current high alarm	See Table Of Threshold Ranges
18-19	2	Bias Low Alarm	Bias current low alarm	See Table Of Threshold Ranges
20-21	2	Bias High Warning	Bias current high warning	See Table Of Threshold Ranges
22-23	2	Bias Low Warning	Bias current low warning	See Table Of Threshold Ranges
24-25	2	TX Power High Alarm	TX power high alarm	See Table Of Threshold Ranges
26-27	2	TX Power Low Alarm	TX power low alarm	See Table Of Threshold Ranges
28-29	2	TX Power High Warning	TX power high warning	See Table Of Threshold Ranges

30-31	2	TX Power Low Warning	TX power low warning	See Table Of Threshold Ranges
32-33	2	RX Power High Alarm	RX power high alarm	See Table Of Threshold Ranges
34-35	2	RX Power Low Alarm	RX power low alarm	See Table Of Threshold Ranges
36-37	2	RX Power High Warning	RX power high warning	See Table Of Threshold Ranges
38-39	2	RX Power Low Warning	RX power low warning	See Table Of Threshold Ranges
40-41	2	Optional Laser Temp High Alarm	Optional laser temp high alarm	See Table Of Threshold Ranges
42-43	2	Optional Laser Temp Low Alarm	Optional laser temp low alarm	See Table Of Threshold Ranges
44-45	2	Optional Laser Temp High Warning	Optional laser temp high warning	See Table Of Threshold Ranges
46-47	2	Optional Laser Temp Low Warning	Optional laser temp low warning	See Table Of Threshold Ranges
48-49	2	Optional TEC Current High Alarm	Optional tec current high alarm	See Table Of Threshold Ranges
50-51	2	Optional TEC Current Low Alarm	Optional tec current low alarm	See Table Of Threshold Ranges
52-53	2	Optional TEC Current High Warning	Optional tec current high warning	See Table Of Threshold Ranges
54-55	2	Optional TEC Current Low Warning	Optional tec current low warning	See Table Of Threshold Ranges
Calibration Constant For External Calibration Option				
56-59	4	RX-PWR(4)	The module only realizes internal correction funtion	00 00 00 00
60-63	4	RX_PWR(3)	The module only realizes internal correction funtion	00 00 00 00
64-67	4	RX_PWR(2)	The module only realizes internal correction funtion	00 00 00 00
68-71	4	RX_PWR(1)	The module only realizes internal correction funtion	3F 80 00 00
72-75	4	RX_PWR(0)	The module only realizes internal correction funtion	00 00 00 00

76-77	2	TX_I(Slope)	The module only realizes internal correction funtion	01 00
78-79	2	TX_I(Offset)	The module only realizes internal correction funtion	00 00
80-81	2	TX_PWR(Slope)	The module only realizes internal correction funtion	01 00
82-83	2	TX_PWR(Offset)	The module only realizes internal correction funtion	00 00
84-85	2	T(Slope)	The module only realizes internal correction funtion	01 00
86-87	2	T(Offset)	The module only realizes internal correction funtion	00 00
88-89	2	V(Slope)	The module only realizes internal correction funtion	01 00
90-91	2	V(Offset)	The module only realizes internal correction funtion	00 00
92-94	3	Unallocated	-	FF FF FF
95	1	Checksum	Byte 95 contains the low order 8 bits of the sum of bytes 0-94	-
A/D Values And Status Bits				
96-97	2	Temperature MSB/LSB	Temperature measured value	Variable
98-99	2	Vcc MSB/LSB	Voltage measured value	Variable
100-101	2	Tx Bias MSB/LSB	Bias current measured value	Variable
102-103	2	TX Power MSB/LSB	Measured TX output power	Variable
104-105	2	RX Power MSB/LSB	Measured RX input power	Variable
106-107	2	Optional Laser Temp/Wavelength MSB/LSB	Measured laser temperature or wavelength	Variable
108-109	2	Optional TEC current MSB/LSB	Measured TEC current (positive is cooling)	Variable
110	1	Status/Control	BIT7 TX_Dis Pin States BIT6 Soft TX_Dis Pin States BIT5 RS(1) Pin States BIT4 RS0 Pin States BIT3 Soft RS0 control bit BIT2 TX_Fault Pin States BIT1 Rx_LOS Pin States BIT0 Data_Ready_Bar Pin States	Variable
111	1	Reserved	Reserved for SFF-8079	00
112	1	Alarm Flags	BIT7 Temp High Alarm BIT6 Temp Low Alarm BIT5 Vcc High Alarm BIT4 Vcc Low Alarm BIT3 TX Bias High Alarm BIT2 TX Bias Low Alarm BIT1 TX Power High Alarm BIT0 TX Power Low Alarm	Variable

113	1	Alarm Flags	BIT7 RX Power High Alarm BIT6 RX Power Low Alarm BIT5 Optional Laser Temp High Alarm BIT4 Optional Laser Temp Low Alarm BIT3 Optional TEC current High Alarm BIT2 Optional TEC current Low Alarm BIT1-BIT0 Reserved	Variable
114	1	Tx Input EQ Control	Unrealized	00
115	1	Rx Out Emphasis Control	Unrealized	00
116	1	Warning Flags	BIT7 Temp High Warning BIT6 Temp Low Warning BIT5 Vcc High Warning BIT4 Vcc Low Warning BIT3 TX Bias High Warning BIT2 TX Bias Low Warning BIT1 TX Power High Warning BIT0 TX Power Low Warning	Variable
117	1	Warning Flags	BIT7 RX Power High Warning BIT6 RX Power Low Warning BIT5 Optional Laser Temp High Warning BIT4 Optional Laser Temp Low Warning BIT3 Optional TEC current High Warning BIT2 Optional TEC current Low Warning BIT1-BIT0 Reserved	Variable
118	1	Ext Status/Control	BIT7-BIT4 BIT2 Reserved BIT3 Soft RS(1) control bit BIT1 Power Level status Value of zero indicates Power Level 1 operation (1.0 W max). Value of one indicates Power Level 2 or 3 operation (1.5 W or 2.0 W max), depending on the values in byte 64 of A0h. BIT0 Power Level control bit Value of zero enables Power Level 1 only (1.0 W max). Value of one enables Power Level 2 or 3 (1.5 W or 2.0 W max), depending on the values in byte 64 of A0h.	00
119	1	Ext Status/Control	BIT7-BIT5 Unallocated BIT4=0 Unallocated BIT3=0 Unallocated BIT2=0 Unallocated BIT1 TX CDR status bit, a value of 0 indicates that the CDR is locked, whereas a value of 1 indicates loss of lock of the CDR BIT0 Rx CDR status bit, a value of 0 indicates that the CDR is locked, whereas a value of 1 indicates loss of lock of the CDR	Variable
General Use Fields				
120-122	3	Reserved	Reserved	00 00 00

123-126	4	Security Level Password	Security level password input area, the written password can be displayed and the default value is 00 00 00 00	00 00 00 00
127	1	Table Select	Table Select	00

Digital Diagnostic Functions

SFP-25G-ER-x-C10 supports the 2-wire serial communication protocol as defined in SFF-8472. Digital diagnostic information is accessible over the 2-wire interface at the address 0xA2. Digital diagnostics for the transceiver are internally calibrated by default. A micro controller unit inside the transceiver gathers the monitoring information and reports the status of transceiver, such as Transceiver Temperature, Supply Power, TX bias current, TX output power, RX received optical power TOSA Temperature and TEC Current.

DDM Threshold Information

Parameter		Alarm Threshold		Warning Threshold	
		High Value	Low Value	High Value	Low Value
Temperature (°C)	C	75 (4B 00)	-5 (FB 00)	70 (46 00)	0 (00 00)
	I	90 (5A 00)	-45 (D3 00)	85 (55 00)	-40 (D8 00)
Vcc (V)		3.63(8D CC)	2.97 (74 04)	3.46 (87 5A)	3.13 (7A 76)
Bias (mA)		120 (EA 60)	20 (27 10)	110 (D6 D8)	25 (30 D4)
TxPower (dBm)		8.16 (FF B8)	-7.0 (07 CB)	6.0 (9B 83)	-3.0 (13 94)
RxPower (dBm)		-1.0 (1F 07)	-24.9 (00 20)	-4.0 (0F 8D)	-21.0 (00 4F)
TOSA Temperature (°C)		70 (46 00)	30 (1E 00)	65 (41 00)	35 (23 00)
TEC Current (A)		1.2 (2E E0)	-0.9 (DC D8)	1.0 (27 10)	-0.7 (E4 A8)

Block-Diagram-of-Transceiver

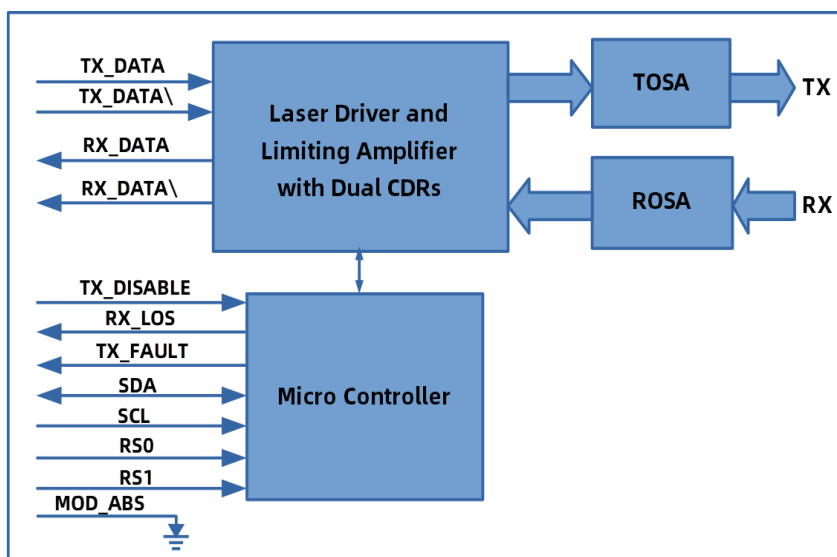

Functions Description

This transceiver consists of a microcontroller, transmitter optical subassembly(TOSA), receiver optical subassembly(ROSA) and multifunctional integrated chip which integrates laser driver, limiting amplifier and dualclock data recovery function (CDR) and so on.

The microcontroller communicates with the host via a 2-wire serial communication interface, providing module control and status reporting. This product compliant with SFF-8472.

The TOSA includes a DFB laser, an electroabsorption modulator (EAM), a TEC, and a monitor photodiode. TEC (Thermo Electric Cooler) controls the temperature of the laser. When a temperature is set, the TOSA temperature of the module will remain unchanged through the control of the TEC. The wavelength of the module laser is related to the temperature of the laser. The module wavelength can be set by setting the TOSA temperature. When the temperature of laser is stable, the module has stable center wavelength.

The laser driver amplifies the high-speed differential signal recovered from the TX CDR, and drives the laser to generate an optical signal, and maintains the stability of the transmitted optical power through an automatic optical power control feedback loop. The electrical signal enters the optical module from the serial electrical interface and is then input to the laser driver chip. The laser driver chip supplies the bias current and the modulation current to the laser. When the transmitter enable pin (TX_Disable) is high (TTL logic "1"), the laser output is turned off. When TX_Disable is low (TTL logic "0"), the laser will turn on within 1ms. When the transmitter fault signal (TX_Fault) is reported as high, indicates a transmitter failure caused by the transmitter's bias current or transmitted optical power or laser tube temperature exceeding a preset alarm threshold. Low indicates normal operation. The module has auto-mute function for TX-Channel, when the amplitude of the electrical signal of the CDR input is lower than the threshold(typical value 50mVpp), the auto-mute for TX-Channel of module is enabled, then the laser still outputs optical power, but the optical eye diagram is changed to a straight line.

ROSA includes a APD (Avalanche photodiode) and a transimpedance amplifier chip. The receiver optical subassembly detects the incident optical signal, converts the optical signal to an electrical signal, and outputs to the limiting amplifier.

The limiting amplifier amplifies the electrical signal converted by the receiver optical subassembly, and outputs the fixed frequency signal to the RX CDR. At the same time, the limiting amplifier detects the amplitude of the electrical signal converted by the receiver optical subassembly, and if it is lower than the set threshold, it reports that the received signal is lost, and pull up the RX_LOS pin on the gold finger. LOS signal is only related to the amplitude of the electrical signal, not to the signal rate and whether the CDR is locked or not. The module has auto-mute function for RX-Channel, when the RX_LOS signal is reported as high(TTL logic "1"), the output eye diagram of the module is a straight line.

A0h、A2h Write Protection

Security Level 1 Password (Factory set value)		
Password Entry ADDR	Size	Vaules(HEX)
Page A2h, 7Bh-7Eh	4	00 00 10 11
Change Security Level 1 Password		
Change Password Entry ADDR	Size	Vaules(HEX)
Page A2h, Table F0h, 80h-83h	4	Programmed by user, 80h.Bit7 must be defined as 0

SFP-25G-ER-x-C10 has write protection functions of A0h and A2h, and users can enter the working state of security level 1 and write to the address of module device A0h and table 00h, table 01h and table F0h of A2h. The method to enter the working state of security level 1 is to write the security level 1 password in the 7Bh-7Eh register of the module A2h address in turn. After entering the security level 1, the user can directly write the contents of the A0h device address, or by modifying the contents of the 7Fh table selection register in the A2h address, write to table 00h or table 01h or table F0h. This version module supports users to modify the password of security level 1 by writing a new security level 1 password in the 80h-83h register in the device address F0h table of module A2h.

Product Weight

Net weight of module : 21.0g/pcs

Net weight of dust cap: 0.95g/pcs

Dimensions

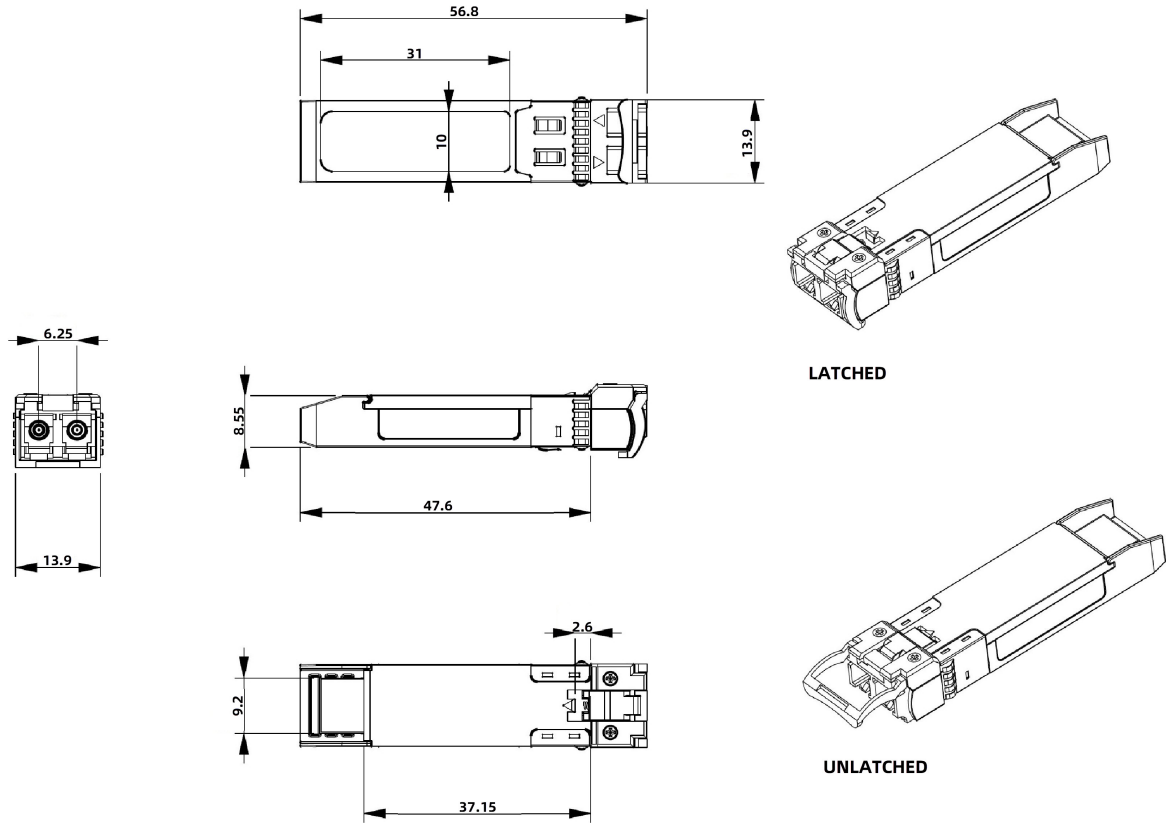

ALL DIMENSIONS ARE ± 0.2 mm UNLESS OTHERWISE SPECIFIED
UNIT: mm

Electrical Pad Layout

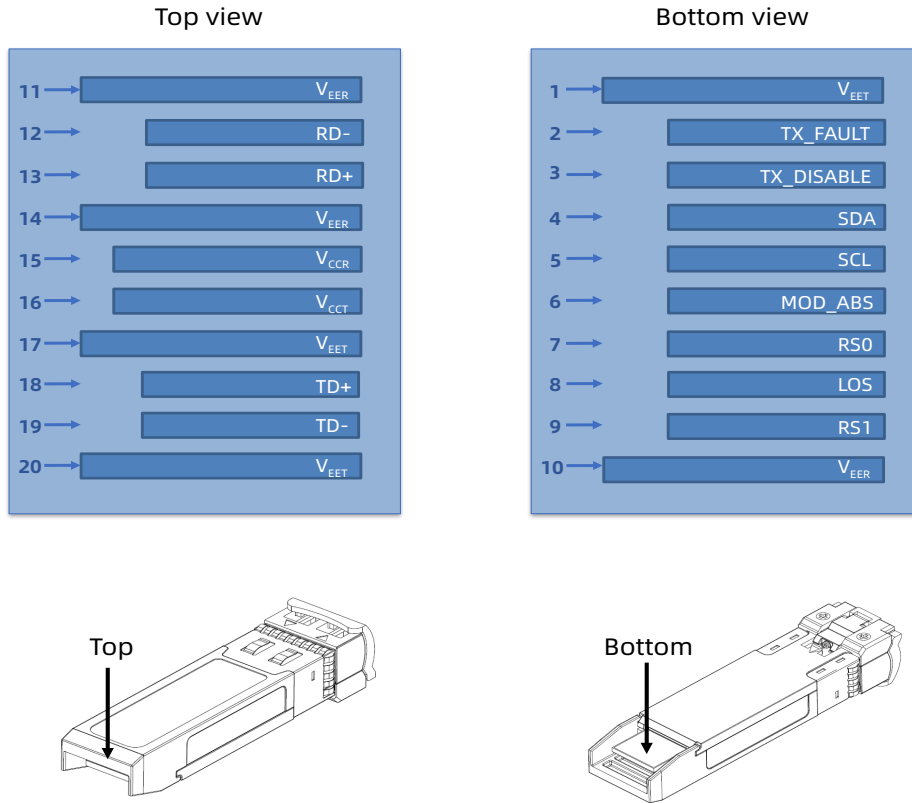

Typical Eye Diagram

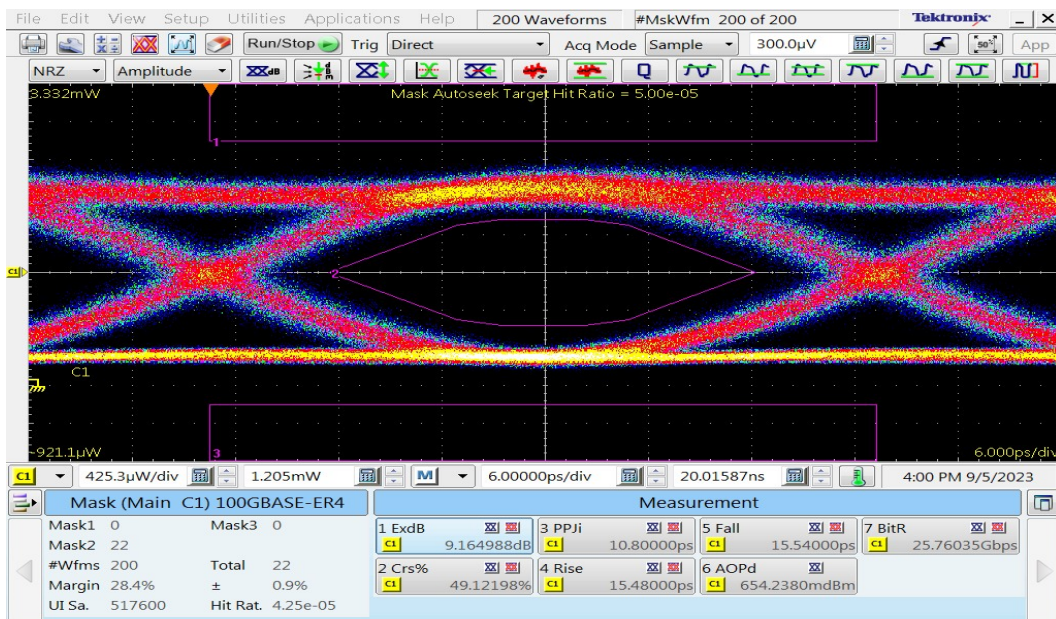

Pin Assignment

PIN #	Symbol	Description	Remarks
1	V _{EET}	Transmitter ground (common with receiver ground)	1
2	TX_FAULT	Transmitter Fault	2
3	TX_DISABLE	Transmitter Disable. Laser output disabled on pin voltage higher than 2.0V or open Laser output enabled on pin voltage lower than 0.8V	3
4	SDA	2-wire Serial Interface Data Line	4
5	SCL	2-wire Serial Interface Clock Line	4
6	MOD_ABS	Module Absent. Grounded within the module	4
7	RS0	No connection required	
8	LOS	Loss of Signal indication. Logic 1 indicates that the signal is lost or the signal does not meet requirements	2
9	RS1	No connection required	
10	V _{EER}	Receiver ground (common with transmitter ground)	1
11	V _{EER}	Receiver ground (common with transmitter ground)	1
12	RD-	Receiver Inverted DATA out. AC coupled	
13	RD+	Receiver Non-inverted DATA out. AC coupled	
14	V _{EER}	Receiver ground (common with transmitter ground)	1
15	V _{CCR}	Receiver power supply	
16	V _{CCT}	Transmitter power supply	
17	V _{EET}	Transmitter ground (common with receiver ground)	1
18	TD+	Transmitter Non-Inverted DATA in. AC coupled	
19	TD-	Transmitter Inverted DATA in. AC coupled	
20	V _{EET}	Transmitter ground (common with receiver ground)	1

Notes:

1. VEET and VEER shall be isolated from the module case
2. This contact is an open collector output contact and should be pulled up with 4.7k-10k ohm on the host to a voltage between 2V and V_{CC} + 0.3V
3. TX_DISABLE is pulled up with 4.7k-10k ohm to VCCT inside the module
4. Should be pulled up with 4.7k-10k ohm on the host to a voltage between 2V and V_{CC} + 0.3V

References

1. Specification for SFP+ 1X Pluggable Transceiver Solutions - SFF-8402 Rev1.2.
2. Specification for SFP+ Module and Cage - SFF-8432 Rev5.2a.
3. Specification for Management Interface for SFP+ - SFF-8472 Rev12.3.