

DATA SHEET

MODULETEK: SFP-25G-DWDM-10KM-xx.xx-x-C10

25Gb/s 100GHZ SFP28 DWDM 10km Transceiver

Overview

ModuleTek's SFP-25G-DWDM-10KM-xx.xx-x-C10 optical transceivers are based on 25G Ethernet IEEE 802.3 standard. They are compliant with SFF-8432 and SFF-8472, providing a fast and reliable interface for 25G Ethernet applications. The product implements digital diagnostics via a 2-wire serial bus and is compliant with the SFF-8472 standard.

Product Features

- Operating data rate support 25.78Gbps
- EML transmitter and PIN photo-detector
- Compliant with IEEE 802.3
- Compliant with SFF-8402
- Compliant with SFF-8432
- Compliant with SFF-8472
- Internal CDR on both Transmitter and Receiver channel
- Hot-pluggable SFP28 footprint
- Duplex LC connector
- Built-in digital diagnostic functions
- Up to 10km on SMF
- Single power supply 3.3V
- RoHS Compliant
- Operating temperature range (Case Temperature): Commercial Level: 0°C to 70°C
Industrial Level: -40°C to 85°C

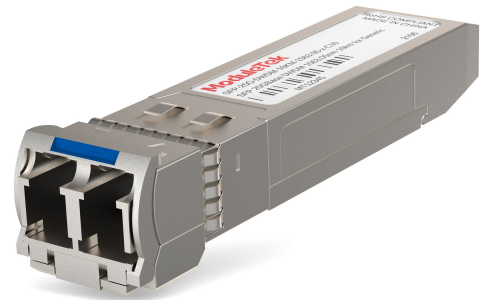

Applications

- 25G Ethernet
- CPRI Option 10

Ordering Information

Part Number	Product ID	Description	Bail Color
SFP-25G-DWDM-10KM-xx.xx-C-C10	M007800	25GBASE DWDM(100GHZ), LC Connectors 10km on SMF, Commercial Temperature	Blue
SFP-25G-DWDM-10KM-xx.xx-I-C10	M007801	25GBASE DWDM(100GHZ), LC Connectors 10km on SMF, Industrial Temperature	Blue
Notes: 1. Product ID is the abbreviated order number of our company's product standard model			
For more information or to order the above products, please contact: Email: sales@moduletek.com Moduletek Web: www.moduletek.com			

Channel Selection

Channel	Wavelength (nm)	Frequency (THZ)	Channel	Wavelength (nm)	Frequency (THZ)
C18	1563.05	191.80	C40	1545.32	194.00
C19	1562.23	191.90	C41	1544.53	194.10
C20	1561.42	192.00	C42	1543.73	194.20
C21	1560.61	192.10	C43	1542.94	194.30
C22	1559.79	192.20	C44	1542.14	194.40
C23	1558.98	192.30	C45	1541.35	194.50
C24	1558.17	192.40	C46	1540.56	194.60
C25	1557.36	192.50	C47	1539.77	194.70
C26	1556.55	192.60	C48	1538.98	194.80
C27	1555.75	192.70	C49	1538.19	194.90
C28	1554.94	192.80	C50	1537.40	195.00
C29	1554.13	192.90	C51	1536.61	195.10
C30	1553.33	193.00	C52	1535.82	195.20
C31	1552.52	193.10	C53	1535.04	195.30
C32	1551.72	193.20	C54	1534.25	195.40
C33	1550.92	193.30	C55	1533.47	195.50
C34	1550.12	193.40	C56	1532.68	195.60
C35	1549.32	193.50	C57	1531.90	195.70
C36	1548.51	193.60	C58	1531.12	195.80
C37	1547.72	193.70	C59	1530.33	195.90
C38	1546.92	193.80	C60	1529.55	196.00
C39	1546.12	193.90	C61	1528.77	196.10

General Specifications

Parameter	Symbol	Min	Typ	Max	Unit	Remarks
Data Rate	DR		25.78		Gb/s	1
Bit Error Rate	BER			5×10^{-5}		2
Operating Temperature	T _C	0		70	°C	3
		-40		85	°C	3
Storage Temperature	T _{STO}	-40		85	°C	4
Supply Current	I _{CC}			600	mA	
Input Voltage	V _{CC}	3.14	3.3	3.46	V	
Power Consumption	P			2	W	
Maximum Voltage	V _{MAX}	0		3.6	V	5

Notes:

1. IEEE 802.3
2. Measured with data rate at 25.78Gb/s, PRBS 2³¹ - 1
3. Case temperature
4. Ambient temperature
5. For electrical power interface

Link Distances

Data Rate	Fiber Type	Distance Range (km)	Remarks
25.78 Gb/s	9/125um SMF	10	1

Notes:

1. This module requires RS-FEC on the host ports for operation at 25G

Optical Characteristics - Transmitter

$V_{CC}=3.14V$ to $3.46V, T_C$

Parameter	Symbol	Min	Typ	Max	Unit	Remarks
Output Optical Power	P_{TX}	-2		6	dBm	1
Optical Center Wavelength	λ_C	$\lambda_C-0.1$	λ_C	$\lambda_C+0.1$	nm	2
Center Wavelength Spacing	GHz		100			
Extinction Ratio	ER	4			dB	
Side Mode Suppression Ratio	SMSR	30			dB	
Transmitter Dispersion Penalty	TDP			4	dB	
Launch Power of OFF Transmitter	P_{OUT_OFF}			-30	dBm	1

Notes:

1. Average Optical Power
2. λ = specified ITU Grid wavelength

Optical - Characteristics - Receiver

$V_{CC}=3.14V$ to $3.46V, T_C$

Parameter	Symbol	Min	Typ	Max	Unit	Remarks
Optical Center Wavelength	λ_C	1270		1610	nm	
Receive Overload	P_{OL}	2			dBm	
Receiver Sensitivity	R_{X_SEN}			-12	dBm	1
LOS Assert	LOS_A	-30			dBm	
LOS De-Assert	LOS_D			-16	dBm	
LOS Hysteresis	LOS_H	0.5			dB	

Notes:

1. Average Optical Power, measured with test signal at 25.78Gb/s, ER > 4dB and PRBS $2^{31}-1$ for BER = 5^{-5} , and without fiber

Electrical Characteristics - Transmitter

$V_{CC}=3.14V$ to $3.46V, T_C$

Parameter	Symbol	Min	Typ	Max	Unit	Remarks
Input differential impedance	R_{IN}		100		Ω	
Differential data input swing	V_{IN_PP}	180		700	mV	
Transmit Disable Voltage	V_D	2		V_{CC}	V	
Transmit Enable Voltage	V_{EN}	V_{EE}		$V_{EE}+0.8$	V	

Electrical - Characteristics - Receiver

$V_{CC}=3.14V$ to $3.46V, T_C$

Parameter	Symbol	Min	Typ	Max	Unit	Remarks
Differential data output swing	V_{OUT_PP}	150		900	mV	
LOS Assert	V_{LOS_A}	2		V_{CC_HOST}	V	
LOS De-Assert	V_{LOS_D}	V_{EE}		$V_{EE}+0.8$	V	

Digital Diagnostic Functions

SFP-25G-DWDM-10KM-xx.xx-x-C10 supports the 2-wire serial communication protocol as defined in SFF-8472. Digital diagnostic information is accessible over the 2-wire interface at the address 0xA2. Digital diagnostics for the transceiver are internally calibrated by default. A micro controller unit inside the transceiver gathers the monitoring information and reports the status of transceiver, such as Transceiver Temperature, Supply Power, TX bias current, TX output power, RX received optical power, TOSA Temperature and TEC Current.

Digital Diagnostic Threshold Range					
Parameter		High Alarm	High Warning	Low Warning	Low Alarm
Temperature (°C)	C	75.00 (4B00h)	70.00 (4600h)	0.00 (0000h)	-5.00 (FB00h)
	I	90.00 (5A00h)	85.00 (5500h)	-40.00 (D800h)	-45.00 (D300h)
Vcc (V)		3.63(8DCCh)	3.46 (875Ah)	3.13 (7A76h)	2.97 (7404h)
Bias (mA)		120.00 (EA60h)	110.00 (D6D8h)	25.00 (30D4h)	20.00 (2710h)
TxPower (dBm)		6.79 (BA9Ch)	6.00 (9B83h)	-2.00 (18A5h)	-2.97 (13B7h)
RxPower (dBm)		5.00 (7BD1h)	2.00 (3DE8h)	-15.00 (013Ch)	-18.00 (009Eh)
TOSA Temperature (°C)		70.00 (4600h)	65.00 (4100h)	35.00 (2300h)	30.00 (1E00h)
TEC Current (A)		1.20 (2EE0h)	1.00 (2710h)	-0.70 (E4A8h)	-0.90 (DCD8h)

A0h/A2h Write Protection

Security Level 1 Password (Factory set value)		
Password Entry ADDR	Size	Vaule(hex)
Page A2h, 7Bh-7Eh	4	00 00 10 11
Change Security Level 1 Password		
Change Password Entry ADDR	Size	Vaule(hex)
Page A2h, Table F0h, 80h-83h	4	Programmed by user, 80h.Bit7 must be defined as 0

SFP-25G-DWDM-10KM-xx.xx-x-C10 has the function of A0h and A2h write-protection. Transceiver need enter the security level 1 working state to write the device address A0h as well as page 00h and page 01h of device address A2h. The method to enter the security level 1 working state is to write the security level 1 password sequentially to bytes 7Bh-7Eh of the device address A2h. After entering the security level 1, the user can either write directly to device address A0h or write to page 00h and page 01h of device address A2h by modifying 7Fh page select byte of the device address A2h. This module supports users to modify the password of security level 1 by writing a new security level 1 password in the 80h-83h register in the device address F0h table of module A2h.

A0h Memory Map

Byte	Size	Name	Description	Initial Value (hex)
0	1	Identifier	SFP/SFP+/SFP28	03
1	1	Extended Identifier	Two-wire interface	04
2	1	Connector	Connector Type = LC	07
3-10	8	Transceiver	25G Base DWDM	00 00 00 00 00 00 00 00
11	1	Encoding	Encoding Type = NRZ	03
12	1	BR, Nominal	Nominal Bit Rate 25.78Gb/s	FF
13	1	Rate Identifier	No rate selection function	00
14	1	Length (9µm)-km	9 µm SMF Link Length = 10 km	0A
15	1	Length (9µm)-100m	9 µm SMF Link Length = 10 km	64
16	1	Length(50µm, OM2)-10m	50 µm OM2 MMF Link Length = N/A	00
17	1	Length (62.5µm, OM1)-10m	62.5 µm OM1 MMF Link Length = N/A	00
18	1	Length (50µm, OM4)-10m	50 µm OM4 MMF Link Length = N/A	00
19	1	Length (50µm, OM3)-10m	50 µm OM3 MMF Link Length = N/A	00
20-35	16	Vendor name	MODULETEK	4D 4F 44 55 4C 45 54 45 4B 20 20 20 20 20 20 20
36	1	Transceiver	25G Base LR	03
37-39	3	Vendor OUI	Without vendor OUI	00 00 00
40-55	16	Vendor PN	Part number in the Ordering Information	Defined by the vendor
56-59	4	Vendor Revision Number	Manufacturer product version number	Defined by the vendor
60-61	2	Wavelength	Laser Wavelength	Defined by the vendor
62	1	Unallocated	Unallocated	00
63	1	CC_BASE	Check sum of bytes 0-62	Defined by the vendor

64	1	Transceiver Options	<p>BIT7:6=0 Reserved BIT5 Power Level Declaration BIT4=1 Paging function is implemented BIT3=1 Retimer or CDR indicator BIT2=1 A cooled laser transmitter implementation BIT1 Power Level Declaration BIT0=0 Receiver output is conventional limiting</p> <p>Commercial Temperature: Power Level 2(<1.5W, BIT5=0, BIT1=1) Industrial Temperature: Power Level 3(<2.0W, BIT5=1, BIT1=0)</p>	1E/3C
65	1	Transceiver Options	<p>BIT7=0 Receiver decision threshold is not implemented BIT6=0 The transmitter wavelength is not tunable BIT5=0 RATE_SELECT functionality is not implemented BIT4=1 TX_DISABLE is implemented BIT3=1 TX_FAULT is implemented BIT2=0 Signal Detect is not implemented BIT1=1 RX_LOS is implemented BIT0=0 Reserved</p>	1A
66	1	BR, max	Upper signaling rate margin	67
67	1	BR, min	Lower signaling rate margin	00
68-83	16	Vendor SN	Manufacturer serial number	Defined by vendor
84-91	8	Date code	Date	Defined by vendor
92	1	Monitoring Type	<p>BIT7=0 Compatible with SFF-8472 requirements BIT6=1 Digital diagnostic function is implemented BIT5=1 Internal calibration is implemented BIT4=0 Externally calibration is not implemented BIT3=1 Received power measurement type is average power BIT2=0 No address change required BIT1:0=0 Reserved</p>	68

93	1	Enhanced Options	<p>BIT7=1 Optional Alarm/Warning flags are implemented for all monitored quantities</p> <p>BIT6=1 Optional soft TX_DISABLE control and monitoring are implemented</p> <p>BIT5=1 Optional soft TX_FAULT monitoring is implemented</p> <p>BIT4=1 Optional soft RX_LOS monitoring is implemented</p> <p>BIT3=0 Optional soft RATE_SELECT control and monitoring are not implemented</p> <p>BIT2=0 Optional Application Select control is not implemented per SFF-8079</p> <p>BIT1=0 Optional soft Rate Select control is not implemented per SFF-8431</p> <p>BIT0=0 Reserved</p>	F0
94	1	Compliance	Includes functionality described in Rev 12.3 of SFF-8472	08
95	1	CC_EXT	Check sum of bytes 64-94	Defined by vendor
96-127	12	Vendor Specific	Vendor specific memory addresses	Defined by vendor
128-255	128	Vendor Specific	Vendor specific memory addresses	Defined by vendor

A2h Memory Map

Byte	Size	Name	Description	Initial Value (hex)
Lower Memory Map(A2h)				
0-1	2	Temp High Alarm	Temperature high alarm threshold	See Table of Threshold Ranges
2-3	2	Temp Low Alarm	Temperature low alarm threshold	See Table of Threshold Ranges
4-5	2	Temp High Warning	Temperature high warning threshold	See Table of Threshold Ranges
6-7	2	Temp Low Warning	Temperature low warning threshold	See Table of Threshold Ranges
8-9	2	Voltage High Alarm	Voltage high alarm threshold	See Table of Threshold Ranges
10-11	2	Voltage Low Alarm	Voltage low alarm threshold	See Table of Threshold Ranges
12-13	2	Voltage High Warning	Voltage high warning threshold	See Table of Threshold Ranges
14-15	2	Voltage Low Warning	Voltage low warning threshold	See Table of Threshold Ranges
16-17	2	Bias High Alarm	Bias current high alarm threshold	See Table of Threshold Ranges
18-19	2	Bias Low Alarm	Bias current low alarm threshold	See Table of Threshold Ranges
20-21	2	Bias High Warning	Bias current high warning threshold	See Table of Threshold Ranges
22-23	2	Bias Low Warning	Bias current low warning threshold	See Table of Threshold Ranges
24-25	2	TX Power High Alarm	TX power high alarm threshold	See Table of Threshold Ranges

26-27	2	TX Power Low Alarm	TX power low alarm threshold	See Table of Threshold Ranges
28-29	2	TX Power High Warning	TX power high warning threshold	See Table of Threshold Ranges
30-31	2	TX Power Low Warning	TX power low warning threshold	See Table of Threshold Ranges
32-33	2	RX Power High Alarm	RX power high alarm threshold	See Table of Threshold Ranges
34-35	2	RX Power Low Alarm	RX power low alarm threshold	See Table of Threshold Ranges
36-37	2	RX Power High Warning	RX power high warning threshold	See Table of Threshold Ranges
38-39	2	RX Power Low Warning	RX power low warning threshold	See Table of Threshold Ranges
40-41	2	Optional Laser Temp High Alarm	Optional laser temp high alarm threshold	See Table of Threshold Ranges
42-43	2	Optional Laser Temp Low Alarm	Optional laser temp low alarm threshold	See Table of Threshold Ranges
44-45	2	Optional Laser Temp High Warning	Optional laser temp high warning threshold	See Table of Threshold Ranges
46-47	2	Optional Laser Temp Low Warning	Optional laser temp low warning threshold	See Table of Threshold Ranges
48-49	2	Optional TEC Current High Alarm	Optional tec current high alarm threshold	See Table of Threshold Ranges
50-51	2	Optional TEC Current Low Alarm	Optional tec current low alarm threshold	See Table of Threshold Ranges
52-53	2	Optional TEC Current High Warning	Optional tec current high warning threshold	See Table of Threshold Ranges
54-55	2	Optional TEC Current Low Warning	Optional tec current low warning threshold	See Table of Threshold Ranges

56-59	4	RX-PWR(4)	External calibration data for RX optical power, the module only implements an internally calibrated function	00 00 00 00
60-63	4	RX_PWR(3)	External calibration data for RX optical power, the module only implements an internally calibrated function	00 00 00 00
64-67	4	RX_PWR(2)	External calibration data for RX optical power, the module only implements an internally calibrated function	00 00 00 00
68-71	4	RX_PWR(1)	External calibration data for RX optical power, the module only implements an internally calibrated function	3F 80 00 00
72-75	4	RX_PWR(0)	External calibration data for RX optical power, the module only implements an internally calibrated function	00 00 00 00
76-77	2	TX_I(Slope)	External calibration data for laser bias current, the module only implements an internally calibrated function	01 00
78-79	2	TX_I(Offset)	External calibration data for laser bias current, the module only implements an internally calibrated function	00 00
80-81	2	TX_PWR(Slope)	External calibration data for TX optical power, the module only implements an internally calibrated function	01 00
82-83	2	TX_PWR(Offset)	External calibration data for TX optical power, the module only implements an internally calibrated function	00 00
84-85	2	T(Slope)	External calibration data for internal module temperature, the module only implements an internally calibrated function	01 00
86-87	2	T(Offset)	External calibration data for internal module temperature, the module only implements an internally calibrated function	00 00
88-89	2	V(Slope)	External calibration data for internal module supply voltage, the module only implements an internally calibrated function	01 00
90-91	2	V(Offset)	External calibration data for internal module supply voltage, the module only implements an internally calibrated function	00 00
92-94	3	Unallocated	Unallocated	FF FF FF
95	1	Checksum	Check sum of bytes 0-94	Defined by vendor

96-97	2	Temperature	Internally measured module temperature, unit is 1/256°C	Variable
98-99	2	Vcc	Internally measured supply voltage in module, unit is 100uV	Variable
100-101	2	TX Bias	Internally measured TX Bias Current, unit is 2uA	Variable
102-103	2	TX Power	Internally measured TX output power, unit is 0.1uW	Variable
104-105	2	RX Power	Internally measured RX input power, unit is 0.1uW	Variable
106-107	2	Optional Laser Temp	Internally measured Measured laser temperature, unit is 0.1mA	00 00
108-109	2	Optional TEC current	Internally measured TEC current, unit is 1/256°C	00 00
110	1	Status/Control	BIT7 TX Disable Input Pin State BIT6=0 Laser disable control bit. Writing '1' disables laser BIT5 RS1 Pin State BIT4 RS0 Pin State BIT3=0 Soft RS0 control bit. Soft Rate Select is not implemented BIT2 TX_Fault Pin State BIT1 RX_LOS Pin State BIT0 Data_Ready_Bar State. Zero/low indicates that the module data is ready	Variable
111	1	Reserved	Reserved for SFF-8079	00
112	1	Alarm Flags	BIT7 Temp High Alarm Flag, active high BIT6 Temp Low AlarmFlag, active high BIT5 Vcc High Alarm Flag, active high BIT4 Vcc Low Alarm Flag, active high BIT3 TX Bias High Alarm Flag, active high BIT2 TX Bias Low Alarm Flag, active high BIT1 TX Power High Alarm Flag, active high BIT0 TX Power Low Alarm, active high	Variable

113	1	Alarm Flags	BIT7 RX Power High Alarm Flag, active high BIT6 RX Power Low Alarm Flag, active high BIT5 Optional Laser Temp High Alarm Flag, active high BIT4 Optional Laser Temp Low Alarm Flag, active high BIT3 Optional TEC current High Alarm Flag, active high BIT2 Optional TEC current Low Alarm Flag, active high BIT1:0 Reserved Alarm Flag	Variable
114	1	Tx input equalization control	This function is not implemented	00
115	1	Rx out emphasis Control	This function is not implemented	00
116	1	Warning Flags	BIT7 Temp High Warning Flag, active high BIT6 Temp Low Warning Flag, active high BIT5 Vcc High Warning Flag, active high BIT4 Vcc Low Warning Flag, active high BIT3 TX Bias High Warning Flag, active high BIT2 TX Bias Low Warning Flag, active high BIT1 TX Power High Warning Flag, active high BIT0 TX Power Low Warning Flag, active high	Variable
117	1	Warning Flags	BIT7 RX Power High Warning Flag, active high BIT6 RX Power Low Warning Flag, active high BIT5 Optional Laser Temp High Warning Flag, active high BIT4 Optional Laser Temp Low Warning Flag, active high BIT3 Optional TEC current High Warning Flag, active high BIT2 Optional TEC current Low Warning Flag, active high BIT1:0 Reserved Warning Flag	Variable
118	1	Ext Status/Control	BIT7:4=0 Reserved BIT3=0 Soft RS1 control bit. Soft Rate Select is not implemented BIT2=0 Reserved BIT1:0=0 Reserved	00

119	1	Ext Status/Control	BIT7:5=0 Unallocated BIT4=0 64GFC Mode Tx Configured, this function is not implemented BIT3=0 64GFC Mode Rx Configured, this function is not implemented BIT2=0 64GFC Mode Configured, this function is not implemented BIT1=0 TX CDR state, this function is not implemented BIT0=0 RX CDR state, this function is not implemented	00
120-122	3	Reserved	Reserved	00 00 00
123-126	4	Security Level Password	Security level password entry. The written value can be read back and the default value on power-up is 00 00 00 00(hex)	00 00 00 00
127	1	Page selection byte	Page selection, select A2h high 128 bytes page	00
Upper Memory Map Page 00/01h				
128-255	128	User Writable EEPROM	User defined, readable and writeable under security level 1	Defined by vendor

Block Diagram of Transceiver

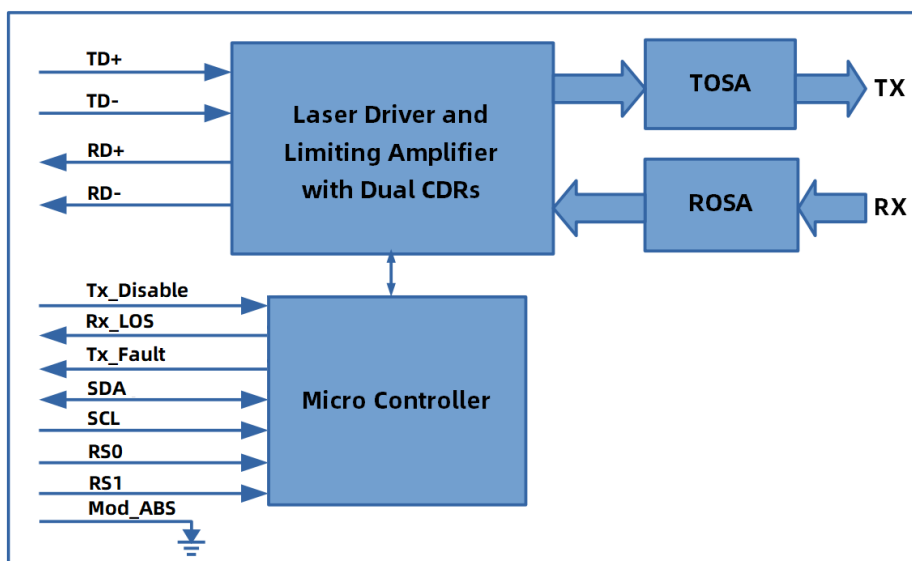

Functions Description

This transceiver consists of a microcontroller, TOSA (Transmitter Optical Sub-Assembly), ROSA (Receiver Optical Sub-Assembly) and multifunctional integrated chip which integrates laser driver, limiting amplifier and dualclock data recovery function (CDR) and so on.

The TOSA includes a DFB laser, an electroabsorption modulator (EAM), a TEC, and a monitor photodiode (MPD). TEC (Thermo Electric Cooler) controls the temperature of the laser. When a temperature is set, the TOSA temperature of the module will remain stable through the control of the TEC. The wavelength of the module laser is related to the temperature of the laser. The module wavelength can be set by setting the TOSA temperature. When the temperature of laser is stable, the module has stable center wavelength.

The laser driver amplifies the high-speed differential signal recovered from the TX CDR, and drives the laser to generate an optical signal, and maintains the stability of the transmitted optical power through an automatic optical power control feedback loop. The electrical signal enters the optical module from the serial electrical interface and is then input to the laser driver chip. The laser driver chip supplies the bias current and the modulation current to the laser. When the transmitter enable pin (TX_DISABLE) is high (logic "1"), the laser output is turned off. When TX_DISABLE is low (logic "0"), the laser will turn on within 1ms. When the transmitter fault signal (TX_FAULT) is reported as high, it indicates that a fault has occurred on the transmitter side. A low level indicates normal operation. The module has auto-mute function for TX-Channel, when the amplitude of the electrical signal of the CDR input is lower than the threshold (typical value 50mVpp), the auto-mute for TX-Channel of module is enabled, then the laser still outputs optical power, but the optical eye diagram is changed to a straight line.

ROSA includes a PIN (Positive-intrinsic-negative photodiode) and a transimpedance amplifier chip. The receiver optical subassembly detects the incident optical signal, converts the optical signal to an electrical signal, and outputs to the limiting amplifier.

The limiting amplifier amplifies the electrical signal converted by the receiver optical subassembly, and outputs the fixed frequency signal to the RX CDR. At the same time, the limiting amplifier detects the amplitude of the electrical signal converted by the receiver optical subassembly, and if it is lower than the set threshold, it reports that the received signal is lost, and pull up the RX_LOS pin on the gold finger. LOS signal is only related to the amplitude of the electrical signal, not to the signal rate and whether the CDR is locked or not. The module has auto-mute function for RX-Channel, when the RX_LOS signal is reported as high(logic "1"), the output eye diagram of the module is a straight line.

Dimensions

Module Weight: 21.0 g

Dust Cap Weight: 0.95 g

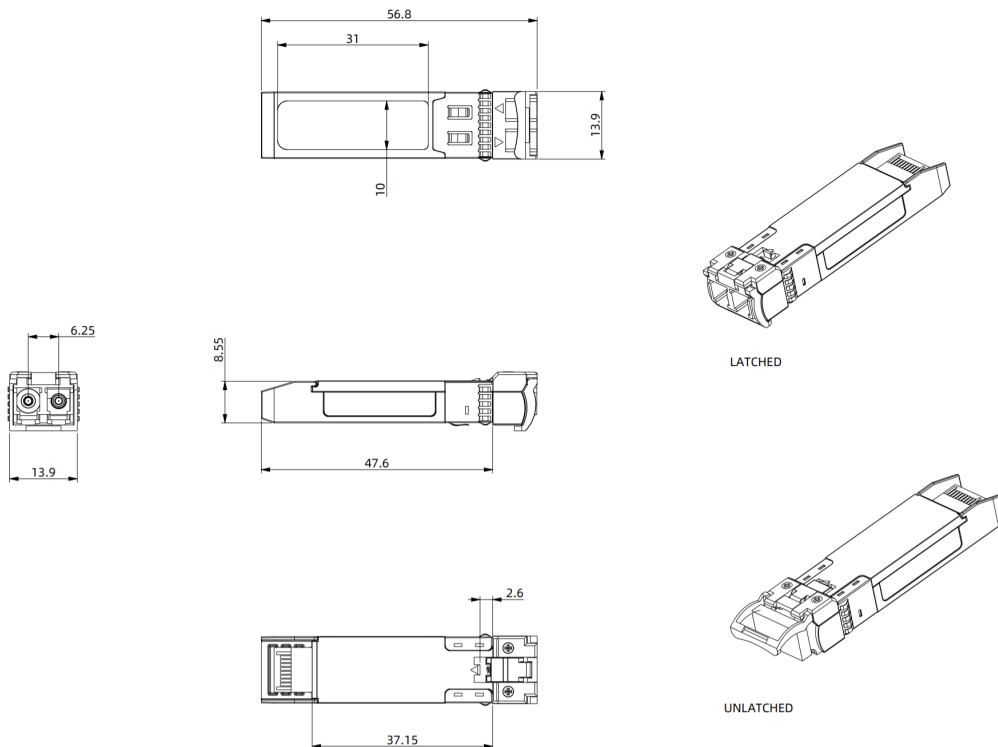

ALL DIMENSIONS ARE $\pm 0.2\text{mm}$ UNLESS OTHERWISE SPECIFIED
UNIT: mm

Electrical Pad Layout

Top view

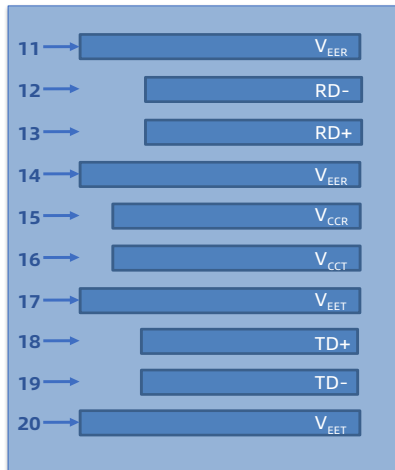

Bottom view

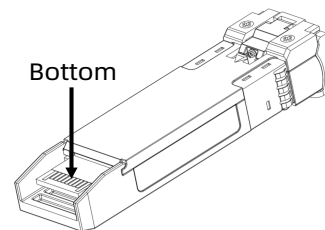
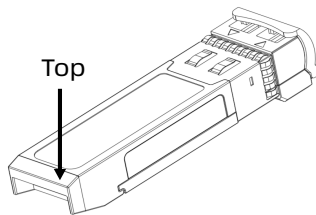
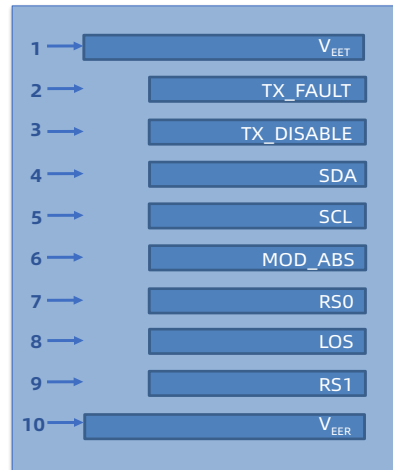

Typical Eye Diagram

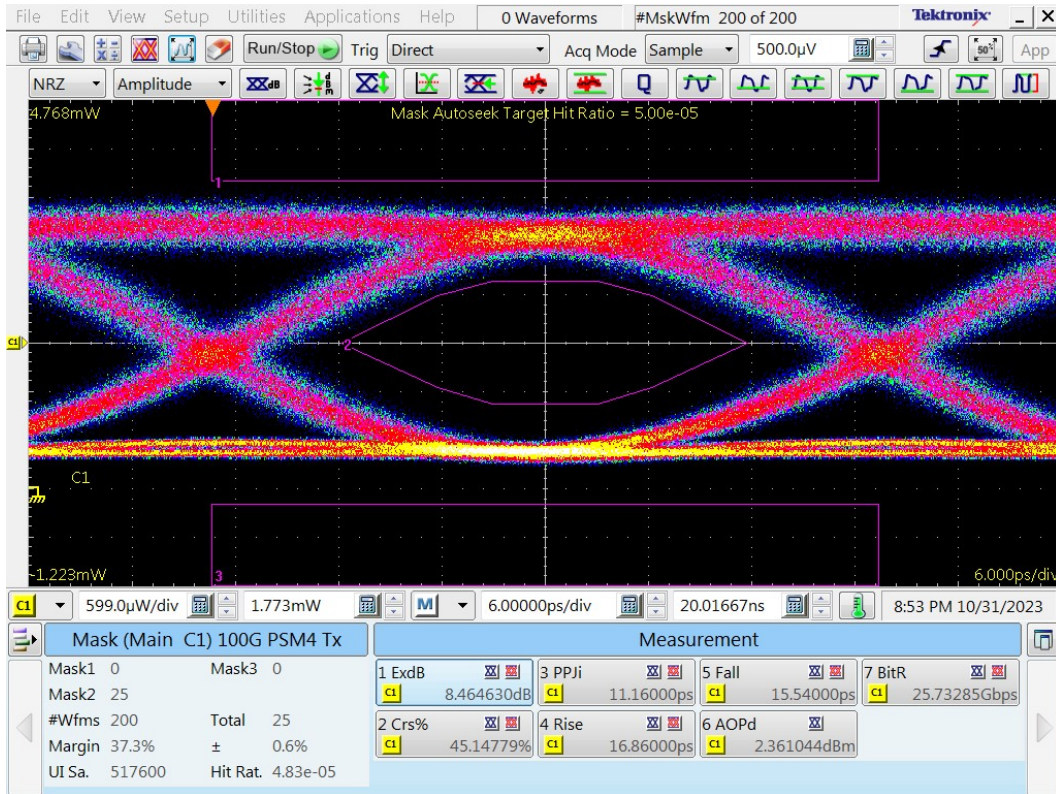

Pin Assignment

PIN #	Symbol	Description	Remarks
1	VeeT	Transmitter ground (common with receiver ground)	1
2	Tx_Fault	Transmitter Fault	
3	Tx_Disable	Transmitter Disable. Laser output disabled on high or open	
4	SDA	2-wire Serial Interface Data Line	
5	SCL	2-wire Serial Interface Clock Line	
6	Mod_ABS	Module Absent. Grounded within the module	
7	RS0	No connection required	
8	Rx_LOS	Loss of Signal indication. Logic 0 indicates normal operation	
9	RS1	No connection required	
10	VeeR	Receiver ground (common with transmitter ground)	1
11	VeeR	Receiver ground (common with transmitter ground)	1
12	RD-	Receiver Inverted DATA out. AC coupled	
13	RD+	Receiver Non-inverted DATA out. AC coupled	
14	VeeR	Receiver ground (common with transmitter ground)	1
15	VccR	Receiver power supply	
16	VccT	Transmitter power supply	
17	VeeT	Transmitter ground (common with receiver ground)	1
18	TD+	Transmitter Non-Inverted DATA in. AC coupled	
19	TD-	Transmitter Inverted DATA in. AC coupled	
20	VeeT	Transmitter ground (common with receiver ground)	1

Notes:

1. Circuit ground is internally isolated from case

References

1. IEEE Std 802.3
2. SFF-8402 SFP28 Pluggable Transceiver Solution
3. SFF-8472 Specification for Management Interface for SFP