

DATA SHEET

MODULETEK: SFP-25G-BIDI-10KM-Txxxx/Rxxxx-x-C12

- 10/25Gb/s SFP28 Tx1270nm/Rx1330nm 10km Bi-directional Transceiver
- 10/25Gb/s SFP28 Tx1330nm/Rx1270nm 10km Bi-directional Transceiver

Overview

ModuleTek's SFP-25G-BIDI-10KM-Txxxx/Rxxxx-x-C12 optical transceivers are based on 25G Ethernet IEEE 802.3cc standard and support 10G and 25G dual rate applications. They are compliant with SFF-8402, SFF-8432 and SFF-8472, providing a fast and reliable interface for 25G Ethernet applications. The product implements digital diagnostics via a 2-wire serial bus and is compliant with the SFF-8472 standard.

Product Features

- Operating data rate support 24.3Gbps - 26.5Gbps with CDR engaged mode
- Operating data rate support 9.95Gbps - 10.31Gbps with CDR bypassed mode
- Compliant with IEEE 802.3cc
- Compliant with SFF-8402
- Compliant with SFF-8432
- Compliant with SFF-8472
- Internal CDR on both Transmitter and Receiver channel
- Hot-pluggable SFP28 footprint
- DFB laser transmitter and PIN PD Receiver
- Simplex LC connector
- Built-in digital diagnostic functions
- Up to 10km on SMF
- Single power supply 3.3V
- RoHS Compliant
- Operating temperature range (Case Temperature): Commercial Level: 0°C to 70°C
Industrial Level: -40°C to 85°C



Applications

- 25GBASE-LR Ethernet
- 10GBASE-LR Ethernet
- CPRI and eCPRI Wireless Networks

Ordering Information

Part Number	Product ID	Description	Bail Color
SFP-25G-BIDI-10KM-T1270/R1330-C-C12	M009908	10/25GBASE SFP28 BIDI, TX1270nm/RX1330nm LC Connector 10km on SMF, Commercial Temperature	Yellow
SFP-25G-BIDI-10KM-T1330/R1270-C-C12	M009910	10/25GBASE SFP28 BIDI, TX1330nm/RX1270nm LC Connector 10km on SMF, Commercial Temperature	Blue
SFP-25G-BIDI-10KM-T1270/R1330-I-C12	M009909	10/25GBASE SFP28 BIDI, TX1270nm/RX1330nm LC Connector 10km on SMF, Industrial Temperature	Yellow
SFP-25G-BIDI-10KM-T1330/R1270-I-C12	M009911	10/25GBASE SFP28 BIDI, TX1330nm/RX1270nm LC Connector 10km on SMF, Industrial Temperature	Blue
<p>Notes:</p> <p>1.Product ID is the abbreviated order number of the standard model of our products</p>			
<p>For More Information: ModuleTek Limited Web: www.moduletek.com Email: sales@moduletek.com</p>			

General Specifications

Parameter	Symbol	Min	Typ	Max	Unit	Remarks
Data Rate1	DR1	24.3		26.5	Gb/s	1
Data Rate2	DR2	9.95		10.31	Gb/s	2
Bit Error Rate1	BER1			5×10^{-5}		3
Bit Error Rate2	BER2			10^{-12}		4
Operating Temperature	T_C	0		70	°C	5
		-40		85	°C	5
Storage Temperature	T_{STO}	-40		85	°C	6
Supply Current (Commercial Temperature)	I_{CC}		220	420	mA	7
Supply Current (Industrial Temperature)	I_{CC}		220	450	mA	7
Input Voltage	V_{CC}	3.14	3.3	3.46	V	
Power Dissipation (Commercial Temperature)	P_C		0.9	1.3	W	
Power Dissipation (Industrial Temperature)	P_I		0.9	1.4	W	
Maximum Voltage	V_{MAX}	-0.5		4	V	7

Notes:

1. IEEE 802.3cc
2. IEEE 802.3ae
3. Measured with data rate at 25.78Gb/s, PRBS $2^{31} - 1$
4. Measured with data rate at 10.31Gb/s, PRBS $2^{31} - 1$
5. Case temperature
6. Ambient temperature
7. For electrical power interface

Link Distances

Data Rate	Fiber Type	Distance Range (km)	Remarks
10.31 Gb/s or 25.78 Gb/s	9/125um SMF	10	1

Notes:

1. This module requires RS-FEC on the host ports for operation at 25G

Optical Characteristics - Transmitter

$V_{CC}=3.14V$ to $3.46V, T_C$

Parameter	Symbol	Min	Typ	Max	Unit	Remarks
Output Optical Power	P_{TX1}	-2		4	dBm	1
Output Optical Power	P_{TX2}	-3		2.5	dBm	1
Optical Center Wavelength (T1270/R1330)	λ_{C1}	1260	1270	1280	nm	
Optical Center Wavelength (T1330/R1270)	λ_{C2}	1320	1330	1340	nm	
Transmitter and Dispersion Penalty	TDP			2.7	dB	
Extinction Ratio	ER	3.5			dB	
Side Mode Suppression Ratio	SMSR	30			dB	
Transmitter Reflectance				-12	dB	
Launch Power of OFF Transmitter	P_{OUT_OFF}			-30	dBm	1

Notes:

1. Average

Optical - Characteristics - Receiver

$V_{CC}=3.14V$ to $3.46V, T_C$

Parameter	Symbol	Min	Typ	Max	Unit	Remarks
Optical Center Wavelength (T1270/R1330)	λ_{C1}	1310	1330	1350	nm	
Optical Center Wavelength (T1330/R1270)	λ_{C2}	1250	1270	1290	nm	
Receive Overload	P_{OL}	2			dBm	
Receiver Sensitivity (OMA)@ 25.78Gb/s	R_{X_SEN1}			-13.3	dBm	1
Receiver Sensitivity (OMA)@ 10.31Gb/s	R_{X_SEN2}			-14	dBm	2
Receiver Reflectance	TR_{RX}			-26	dB	
LOS Assert	LOS_A	-30			dBm	
LOS De-Assert	LOS_D			-17	dBm	
LOS Hysteresis	LOS_H	0.5			dB	

Notes:

1. Measured with data rate at 25.78Gb/s, PRBS $2^{31}-1$, BER 5×10^{-5} ;
2. Measured with data rate at 10.31Gb/s, PRBS $2^{31}-1$, BER 10^{-12} ;

Electrical Characteristics - Transmitter

$V_{CC}=3.14V$ to $3.46V, T_C$

Parameter	Symbol	Min	Typ	Max	Unit	Remarks
Input differential impedance	R_{IN}		100		Ω	
Differential data input swing	V_{IN_PP}	200		900	mV	
Transmit Disable Voltage	V_D	2		V_{CC}	V	
Transmit Enable Voltage	V_{EN}	V_{EE}		$V_{EE}+0.8$	V	

Electrical - Characteristics - Receiver

$V_{CC}=3.14V$ to $3.46V, T_C$

Parameter	Symbol	Min	Typ	Max	Unit	Remarks
Differential data output swing	V_{OUT_PP}	300		850	mV	
LOS Assert	V_{LOS_A}	2		V_{CC_HOST}	V	
LOS De-Assert	V_{LOS_D}	V_{EE}		$V_{EE}+0.8$	V	

A0H Register Description

IIC Addr	Size	Name	Description	Values(HEX)
0	1	Identifier	SFP/SFP+/SFP28	03
1	1	Extended Identifier	Use IIC interface	04
2	1	Connector	Connector Type = LC	07
3-10	8	Transceiver	25G Base LR	00 00 00 00 00 00 00 00
11	1	Encoding	Encoding Type = NRZ	03
12	1	BR, Nominal	Nominal Bit Rate 25.78Gb/s	FF
13	1	Rate Identifier	Without rate selection function	00
14	1	Length(9µm)-km	Link Length / SMF = 10km	0A
15	1	Length (9µm)-100m	Link Length / SMF = 10km	64
16	1	Length (50µm)-10m	50µm MMF Link Length = N/A	00
17	1	Length (62.5µm)-10m	62.5µm MMF Link Length = N/A	00
18	1	Length (Copper)	Copper Link Length = N/A	00
19	1	Reserved	Reserved	00
20-35	16	Vendor name	MODULETEK	4D 4F 44 55 4C 45 54 45 4B 20 20 20 20 20 20 20
36	1	Transceiver	25G Base LR	03
37-39	3	Vendor OUI	Without vendor OUI	00 00 00
40-55	16	Vendor PN	Part number in the Ordering Information	Programmed by Factory
56-59	4	Vendor Revision Number	Manufacturer product version number	Programmed by Factory
60-61	2	Wavelength	Laser Wavelength	Programmed by Factory
62	1	Reserved	Reserved	00
63	1	CC_BASE	Checksum of bytes 0-62	Programmed by Factory
64-65	2	Transceiver Options	1.Internal CDR 2.Rx_LOS 3.Tx_FAULT 4.Tx_DIS	08 1A
66	1	BR, max	103% for 25.78Gbit/s	67
67	1	BR, min	NA	00
68-83	16	Vendor SN	Manufacturer serial number	Programmed by Factory
84-91	8	Date code	Date code	Programmed by Factory
92	1	Monitoring Type	Internal calibration of DOM RxPower measurement using average optical power	68
93	1	Enhanced Options	1.Monitor Alarm and Warning of TxPower and RxPower 2.Tx_DIS Monitor and Control 3.Rx_LOS Monitor 4.Tx_FAULT Monitor	F0
94	1	Compliance	Revision Implemented	08
95	1	CC_EXT	Check sum of bytes 64-94	Programmed by Factory
96-127	32	Vendor Specific	Vendor Specific Area	Programmed by Factory
128-255	128	Vendor Specific	Vendor Specific Area	Programmed by Factory

Digital Diagnostic Functions

SFP-25G-BIDI-10KM-Txxxx/Rxxxx-x-C12 supports the 2-wire serial communication protocol as defined in SFF-8472. Digital diagnostic information is accessible over the 2-wire interface at the address 0xA2. Digital diagnostics for the transceiver are internally calibrated by default. A micro controller unit inside the transceiver gathers the monitoring information and reports the status of transceiver, such as Transceiver Temperature, Supply Power, TX bias current, TX output power and RX received optical power.

DDM Threshold Information

Parameter		Alarm Threshold		Warning Threshold	
		High Value	Low Value	High Value	Low Value
Temperature (°C)	C	90 (5A 00)	-10 (F6 00)	85 (55 00)	-5 (FB 00)
	I	90 (5A 00)	-45 (D3 00)	85 (55 00)	-40 (D8 00)
Vcc (V)		3.63(8D CC)	2.97 (74 04)	3.46 (87 28)	3.13 (7A 44)
Bias (mA)		100 (C3 50)	2 (03 E8)	80 (9C 40)	4 (07 D0)
TxPower (dBm)		4.8 (75 BE)	-2.97 (13 B7)	4.0 (62 1E)	-2.0 (18 A5)
RxPower (dBm)		3.5 (57 A8)	-18.0 (00 9E)	0.5 (2B D4)	-15.0 (01 3C)

Block-Diagram-of-Transceiver

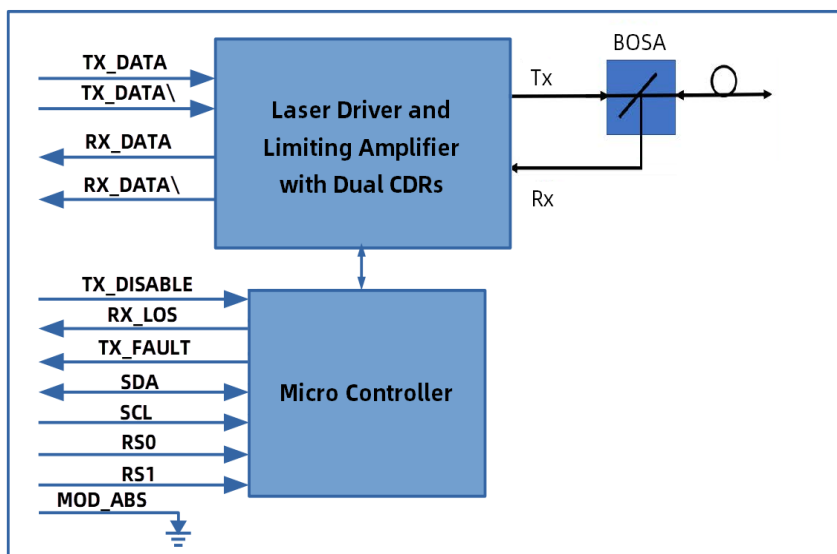

Functions Description

MODULETEK's SFP-25G-BIDI-10KM-Txxxx/Rxxxx-x-C12 module consists of a microcontroller, integrated dual-clock data recovery function (CDR) laser drive and limiting amplifier, and a Transmitter and a Receiver.

The microcontroller communicates with the host via a 2-wire serial communication interface, providing module control, status reporting and monitoring functions (DOM). This product Compliant with SFF-8472.

The laser driver amplifies the high-speed differential signal recovered from the TX CDR, and drives the laser to generate an optical signal, and maintains the stability of the transmitted optical power through an automatic optical power control feedback loop.

The limiting amplifier amplifies the electrical signal converted by the light receiving component, and outputs the fixed frequency signal to the RX CDR. At the same time, the limiting amplifier detects the amplitude of the electrical signal converted by the light receiving component, and if it is lower than the set threshold, it reports that the received signal is lost, and raise the RX_LOS pin level on the gold finger. LOS signal is only related to the amplitude of the electrical signal, not to the signal rate and whether the CDR is locked or not.

The transmitter of the transceiver adopts a TO-CAN structure within a BOSA, and is composed of a DFB laser and a monitoring photodiode(MPD). The laser generates a corresponding optical signal according to a bias current and a modulation current provided by the laser driver, and the MPD will continuously monitor the TX power.

The Receiver of the transceiver also uses a TO-CAN structure within a BOSA, including a PIN photodetector(PIN PD) and a trans-impedance amplifier(TIA). When ROSA detects the incident light signal, it will be converted into photo-generated current by the PIN PD. The photo-generated current is converted into an electrical signal through the TIA and input to the limiting amplifier. After the module is powered on, the read value of the security level access registers 7BH ~ 7EH of A2H is replaced with 0x00. After the content of this group of registers is updated, the read value is the last written value. The security level 1 password of this module is 0x00001011. The method to enter the security level 1 working state is to convert and write the security level 1 password in the A2H 7BH ~ 7EH registers of the module, namely 0x00, 0x00, 0x10, 0x11. After entering the security level 1 working state, the user can directly write to the content of the A0H device address, or modify the content of the A2H 7FH table selection register to write to the contents of Table 00 or Table 01. And this version of the module does not support users to modify the security level 1 password.

The transceiver supports high data rates 24.33G/25.78G(CPRI options 10/25GbE) and low data rates 9.95G/10.31G(10GbE-LW/LR) CDRs at transmitter and receiver are configured according to different signal rates.

We can provide different CDR configurations for different applications, such as 25G single-rate application, full-rate CDR bypass application and so on. For more details, please contact our sales.

Product Weight

Net weight of module : 19.5g/pcs

Net weight of dust cap: 0.60g/pcs

Dimensions

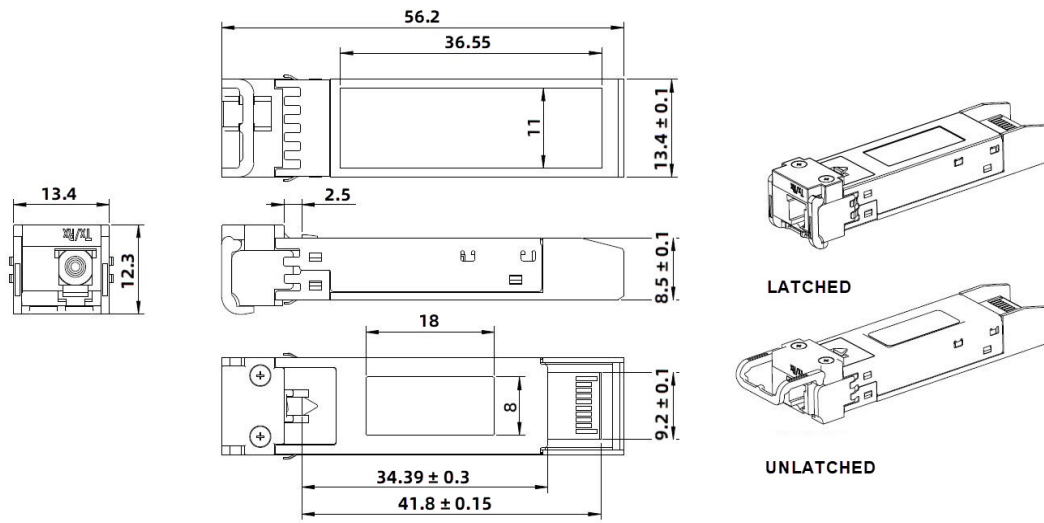

ALL DIMENSIONS ARE ±0.2mm UNLESS OTHERWISE SPECIFIED
UNIT: mm

Electrical Pad Layout

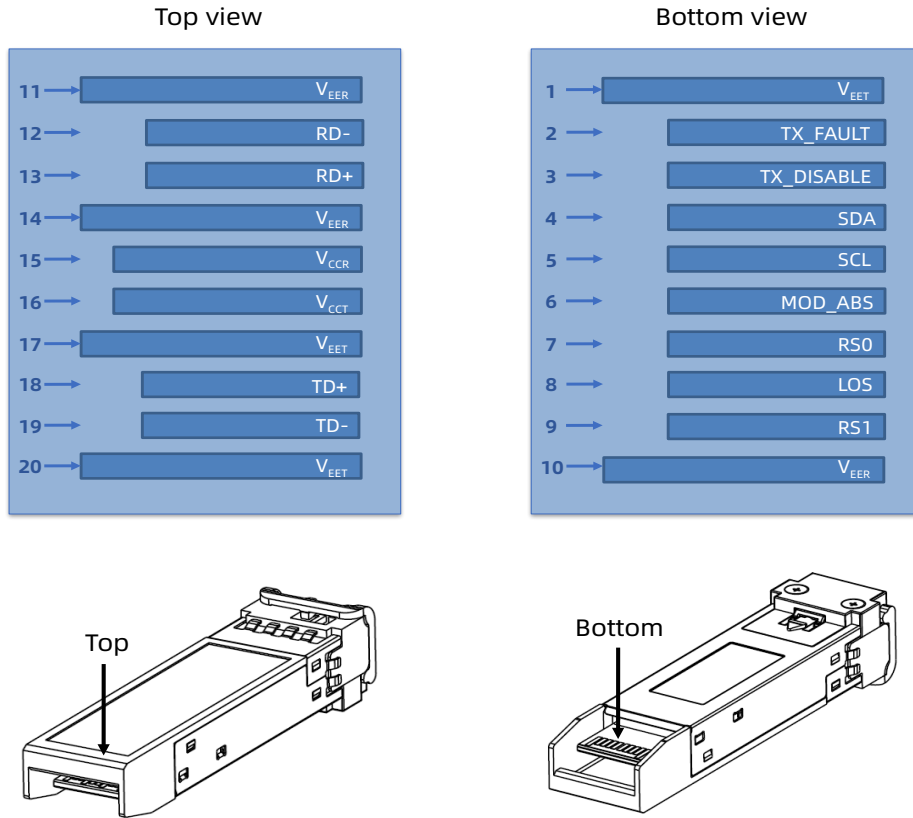

Typical Eye Diagram

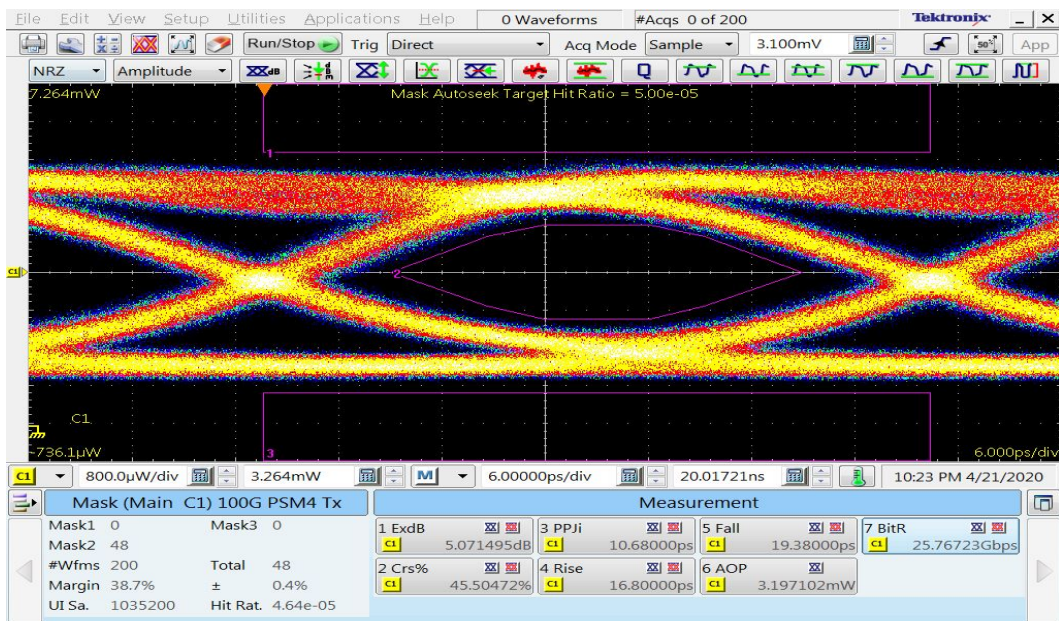

Pin Assignment

PIN #	Symbol	Description	Remarks
1	V _{EET}	Transmitter ground (common with receiver ground)	1
2	TX_FAULT	Transmitter Fault	2
3	TX_DISABLE	Transmitter Disable. Laser output disabled on high or open	3
4	SDA	2-wire Serial Interface Data Line	4
5	SCL	2-wire Serial Interface Clock Line	4
6	MOD_ABS	Module Absent. Grounded within the module	4
7	RS0	Receiver rate selection, Unused	
8	LOS	Loss of Signal indication. Logic 0 indicates normal operation	5
9	RS1	Transmitter rate selection, Unused	
10	V _{EER}	Receiver ground (common with transmitter ground)	1
11	V _{EER}	Receiver ground (common with transmitter ground)	1
12	RD-	Receiver Inverted DATA out. AC coupled	
13	RD+	Receiver Non-inverted DATA out. AC coupled	
14	V _{EER}	Receiver ground (common with transmitter ground)	1
15	V _{CCR}	Receiver power supply	
16	V _{CCT}	Transmitter power supply	
17	V _{EET}	Transmitter ground (common with receiver ground)	1
18	TD+	Transmitter Non-Inverted DATA in. AC coupled	
19	TD-	Transmitter Inverted DATA in. AC coupled	
20	V _{EET}	Transmitter ground (common with receiver ground)	1

Notes:

1. Circuit ground is isolated from chassis ground
2. TX_FAULT is the open collector output and should be pulled up with 4.7k-10k ohm on host board to a voltage between 2V and V_{CC} + 0.3V
3. Disabled: T_{DIS} > 2V or open, Enabled: T_{DIS} < 0.8V
4. Should be pulled up with 4.7k –10k ohm on host board to a voltage between 2V and V_{CC} + 0.3V
5. LOS is open collector output and should be pulled up with 4.7k –10k ohm on host board to a voltage between 2V and V_{CC} +0.3V, the logic "0" indicates normal operation, and the logic "1" indicates that the receiver signal is lost.

References

1. Specification for SFP+ 1X Pluggable Transceiver Solution - SFF-8402.
2. Specification for SFP+ Module and Cage - SFF-8432.
3. Specification for Diagnostic Monitoring Interface for SFP+ - SFF-8472.