

DATA SHEET

MODULETEK: SFP-10/25G-SR-C-D17

10/25 Gb/s SFP SR Transceiver Suitable for CISCO host

Overview

SFP-10/25G-SR-C-D17 optical transceiver is based on 25 Gb/s Ethernet IEEE 802.3 standard and supports 10 Gb/s and 25 Gb/s dual-rate applications. It complies with SFF-8402 standard, providing a high-speed and reliable interface for 25 Gb/s Ethernet applications. The product supports digital diagnostics via a 2-wire serial bus, compliant with the SFF-8472 standard.

Product Features

- Compliant with IEEE 802.3
- Compliant with SFF-8402
- Hot-pluggable SFP footprint
- 850 nm VCSEL laser transmitter and PIN PD receiver
- Duplex LC connector
- Built-in digital diagnostic functions
- Single power supply 3.3 V
- RoHS Compliant
- Internal CDR on both transmitter and receiver channel
- Operating data rate support 25.78 Gb/s with CDR engaged mode
- Operating data rate support 10.31 Gb/s with CDR bypassed mode
- Operating temperature range (Case Temperature) : Commercial Level : 0 °C to 70 °C



Applications

- 25GBASE-SR Ethernet
- 10GBASE-SR Ethernet
- eCPRI Wireless Networks

Ordering Information

Part Number	Product ID	Description	Color on Clasp
SFP-10/25G-SR-C-D17	M600508	10/25GBASE-SR SFP 850 nm LC Connectors	Black
Notes: 1. Product ID is the abbreviated order number of our company's product standard model			
For more information or to order the above product, please contact: Email: sales@moduletek.com ModuleTek Website: www.moduletek.com			

General Specifications

Parameter	Symbol	Min	Typ	Max	Unit	Remarks
Line Rate @ 25 Gb/s	BR		25.78		Gb/s	1
Line Rate @ 10 Gb/s	BR		10.31		Gb/s	1
Bit Error Rate @ 25 Gb/s	BER			5×10^{-5}		2
Bit Error Rate @ 10 Gb/s	BER			1×10^{-12}		3
Operating Temperature	T _C	0		70	°C	4
Storage Temperature	T _{STO}	-40		85	°C	5
Input Voltage	V _{CC}	3.13	3.3	3.46	V	
Power Dissipation	P _I		0.55	0.7	W	
Maximum Voltage	V _{MAX}	-0.5		4	V	6

Notes:

1. IEEE 802.3
2. Measured with line rate at 25.78 Gb/s, PRBS 2³¹ - 1
3. Measured with line rate at 10.31 Gb/s, PRBS 2³¹ - 1
4. Case temperature
5. Ambient temperature
6. For electrical power interface

Link Distances

Line Rate	Fiber Type	Distance Range (m)	Remarks
25.78 Gb/s	OM3 Multimode Fiber (Bandwidth 2000 MHz*km)	70	1
25.78 Gb/s	OM4 Multimode Fiber (Bandwidth 4700 MHz*km)	100	1
10.31 Gb/s	OM3 Multimode Fiber (Bandwidth 2000 MHz*km)	300	
10.31 Gb/s	OM4 Multimode Fiber (Bandwidth 4700 MHz*km)	400	

Notes:

1. This module requires RS-FEC on the host ports for operation at 25G

Optical Characteristics - Transmitter

$V_{CC} = 3.13\text{ V to }3.46\text{ V}$, T_C

Parameter	Symbol	Min	Typ	Max	Unit	Remarks
Output Optical Power @ 25 Gb/s	P_{TX}	-8.4		2.4	dBm	1
Output Optical Power @ 10 Gb/s	P_{TX}	-7		-1	dBm	1
Optical Center Wavelength	λ_C	840	850	860	nm	
Transmitter Dispersion Eye Closed @ 25 Gb/s	TDEC			4.3	dB	
Transmitter Dispersion Penalty @ 10 Gb/s	TDP			3.9	dB	
Extinction Ratio @ 25 Gb/s	ER	2			dB	
Extinction Ratio @ 10 Gb/s	ER	3			dB	
Spectral Width (-20 dB)	$\Delta\lambda$			0.6	nm	
Launch Power of OFF Transmitter	P_{OUT_OFF}			-30	dBm	1

Notes:

1. Average optical power

Optical Characteristics - Receiver

$V_{CC} = 3.13\text{ V to }3.46\text{ V}, T_C$

Parameter	Symbol	Min	Typ	Max	Unit	Remarks
Optical Center Wavelength	λ_C	840		860	nm	
Receiver Sensitivity @ 25 Gb/s	P_{RX}	-10.3		2.4	dBm	1
Receiver Sensitivity @ 10 Gb/s	P_{RX}	-10		0.5	dBm	2
LOS Assert	LOS_A	-30			dBm	
LOS De-Assert	LOS_D			-11	dBm	
LOS Hysteresis	LOS_H	0.5			dB	

Notes:

1. Average optical power, measured with test signal at 25.78 Gbps and PRBS 231 -1 for BER = 5×10^{-5} , and without fiber
2. Average optical power, measured with test signal at 10.31 Gbps and PRBS 231 -1 for BER = 1×10^{-12}

Electrical Characteristics - Transmitter

$V_{CC} = 3.13\text{ V to }3.46\text{ V}, T_C$

Parameter	Symbol	Min	Typ	Max	Unit	Remarks
Input Differential Impedance	R_{IN}		100		Ω	
Differential Data Input Swing	V_{IN_PP}	250		900	mV	
Transmitter Disable Voltage	V_D	2		V_{CC}	V	
Transmitter Enable Voltage	V_{EN}	V_{EE}		$V_{EE}+0.8$	V	

Electrical Characteristics - Receiver

$V_{CC} = 3.13\text{ V to }3.46\text{ V}, T_C$

Parameter	Symbol	Min	Typ	Max	Unit	Remarks
Differential Data Output Swing	V_{OUT_PP}	370	600	850	mV	
LOS Assert	V_{LOS_A}	2		V_{CC_HOST}	V	
LOS De-Assert	V_{LOS_D}	V_{EE}		$V_{EE}+0.8$	V	

Digital Diagnostic Function

SFP-10/25G-SR-C-D17 supports the 2-wire serial communication protocol defined in SFF-8472, which provides access to digital diagnostic information through a 2-wire interface with the address A2h. Digital diagnostics are internally calibrated, and the internal microcontroller provides real-time access to module operating parameters such as module temperature, laser bias current, transmit optical power, receive optical power and module supply voltage. The module features rate selection capability, and when switching between different rates, the threshold range for digital diagnostics remains unchanged. The module implements the SFF-8472's alarm function, which alerts the user when specific operating parameters are out of normal range.

Digital Diagnostic Threshold Range				
Parameter	High Alarm	High Warning	Low Warning	Low Alarm
Temperature (°C)	75.00 (4B00h)	70.00 (4600h)	0.00 (0000h)	-5.00 (FB00h)
Voltage (V)	3.63 (8DCCh)	3.46 (8728h)	3.13 (7A44h)	2.97 (7404h)
Bias Current (mA)	12.00 (1770h)	11.50 (1676h)	2.00 (03E8h)	1.00 (01F4h)
Tx Power (dBm)	3.40 (5575h)	2.40 (43E2h)	-8.40 (05A5h)	-9.40 (047Ch)
Rx Power (dBm)	3.40 (5575h)	2.40 (43E2h)	-10.30 (03A5h)	-11.30 (02E5h)

A0h/A2h Write Protection

Security Level 1 Password (Factory Value)		
Password Entry Bytes	Size	Value (hex)
A2h, 7Bh-7Eh	4	00 00 10 11
Change Security Level 1 Password		
Change Password Entry Bytes	Size	Value (hex)
A2h, Page F0h, 80h-83h	4	Programmed by User

SFP-10/25G-SR-C-D17 has the function of A0h and A2h write-protection. Transceiver need enter the security level 1 working state to write the device address A0h as well as page 00h, page 01h and page F0h of device address A2h. The method to enter the security level 1 working state is to write the security level 1 password sequentially to bytes 7Bh-7Eh of the device address A2h. After entering the security level 1, the user can either write directly to device address A0h or write to page 00h, page 01h and page F0h of device address A2h by modifying 7Fh page select byte of the device address A2h. This version module supports users to modify the password of security level 1 by writing a new security level 1 password in the 80h-83h register in the device address F0h page of module A2h. The new security level 1 password ranges from 00000000-7FFFFFFF (hex), and the highest bit of the new security level 1 password must be 0b.

A0h Memory Map

Byte	Size	Name	Description	Initial Value (hex)
0	1	Identifier	SFP	03
1	1	Extended Identifier	Two-wire interface	04
2	1	Connector	Connector type = LC	07
3-10	8	Transceiver	25GBASE-SR	00 00 00 00 00 00 00 00
11	1	Encoding	NRZ	03
12	1	BR, Nominal	Nominal bit rate 25.78 Gb/s	FF
13	1	Rate Identifier	Rate selection function is implemented	0C
14	1	Length (9 μ m)-km	9 μ m SMF link length = N/A	00
15	1	Length (9 μ m)-100 m	9 μ m SMF link length = N/A	00
16	1	Length (50 μ m, OM2)-10 m	50 μ m OM2 MMF link length = N/A	00
17	1	Length (62.5 μ m, OM1)-10 m	62.5 μ m OM1 MMF link length = N/A	00
18	1	Length (50 μ m, OM4)-10 m	50 μ m OM4 MMF link length = 100 m	0A
19	1	Length (50 μ m, OM3)-10 m	50 μ m OM3 MMF link length = 70 m	07
20-35	16	Vendor name	MODULETEK	4D 4F 44 55 4C 45 54 45 4B 20 20 20 20 20 20 20
36	1	Transceiver	Undefined	00
37-39	3	Vendor OUI	Without vendor OUI	00 00 00
40-55	16	Vendor PN	Part number provided by SFP vendor	ASCII Format
56-59	4	Vendor Revision	Revision level for part number provided by vendor	Defined by vendor
60-61	2	Wavelength	Laser wavelength 850 nm	03 52
62	1	Reserved	Reserved	00
63	1	CC_BASE	Check sum of bytes 0-62	Defined by vendor

64	1	Transceiver Options	BIT7:6 = 0 Reserved BIT5 = 0 Power level 1, < 1.0 W BIT4 = 1 Paging function is implemented BIT3 = 1 With retimer or CDR indicator BIT2 = 0 Uncooled laser transmitter BIT1 = 0 Power level 1, < 1.0 W BIT0 = 0 Receiver output is conventional limiting	18
65	1	Transceiver Options	BIT7 = 0 Receiver decision threshold is not implemented BIT6 = 0 The transmitter wavelength is not tunable BIT5 = 1 RATE_SELECT functionality is implemented BIT4 = 1 Tx_Disable is implemented BIT3 = 1 Tx_Fault is implemented BIT2 = 0 Signal detect is not implemented BIT1 = 1 Rx_LOS is implemented BIT0 = 0 Reserved	3A
66	1	BR, nominal	BR, nominal	67
67	1	BR, deviation	BR, deviation	00
68-83	16	Vendor SN	Manufacturer serial number	Defined by vendor
84-91	8	Date code	Date	Defined by vendor
92	1	Monitoring Type	BIT7 = 0 Compatible with SFF-8472 requirements BIT6 = 1 Digital diagnostic function is implemented BIT5 = 1 Internal calibration is implemented BIT4 = 0 Externally calibration is not implemented BIT3 = 1 Received power measurement type is average power BIT2 = 0 No address change required BIT1:0 = 0 Reserved	68

93	1	Enhanced Options	<p>BIT7 = 1 Optional Alarm/Warning flags are implemented for all monitored quantities</p> <p>BIT6 = 1 Optional soft Tx_Disable control and monitoring are implemented</p> <p>BIT5 = 1 Optional soft Tx_Fault monitoring is implemented</p> <p>BIT4 = 1 Optional soft Rx_LOS monitoring is implemented</p> <p>BIT3 = 1 Optional soft RATE_SELECT control and monitoring are implemented</p> <p>BIT2 = 0 Optional application select control is not implemented per SFF-8079</p> <p>BIT1 = 1 Optional soft rate select control is implemented per SFF-8431</p> <p>BIT0 = 0 Reserved</p>	FA
94	1	Compliance	Includes functionality described in Rev 12.3 of SFF-8472	08
95	1	CC_EXT	Check sum of bytes 64-94	Defined by vendor
96-127	32	Vendor Specific	Vendor specific memory addresses	Defined by vendor
128-255	128	Vendor Specific	Vendor specific memory addresses	Defined by vendor

A2h Memory Map

Byte	Size	Name	Description	Initial Value (hex)
Lower Memory Map(A2h)				
00-01	2	Temp High Alarm	Temperature high alarm threshold	See Table of Threshold Ranges
02-03	2	Temp Low Alarm	Temperature low alarm threshold	See Table of Threshold Ranges
04-05	2	Temp High Warning	Temperature high warning threshold	See Table of Threshold Ranges

06-07	2	Temp Low Warning	Temperature low warning threshold	See Table of Threshold Ranges
08-09	2	Voltage High Alarm	Voltage high alarm threshold	See Table of Threshold Ranges
10-11	2	Voltage Low Alarm	Voltage low alarm threshold	See Table of Threshold Ranges
12-13	2	Voltage High Warning	Voltage high warning threshold	See Table of Threshold Ranges
14-15	2	Voltage Low Warning	Voltage low warning threshold	See Table of Threshold Ranges
16-17	2	Bias High Alarm	Bias current high alarm threshold	See Table of Threshold Ranges
18-19	2	Bias Low Alarm	Bias current low alarm threshold	See Table of Threshold Ranges
20-21	2	Bias High Warning	Bias current high warning threshold	See Table of Threshold Ranges
22-23	2	Bias Low Warning	Bias current low warning threshold	See Table of Threshold Ranges
24-25	2	TX Power High Alarm	TX power high alarm threshold	See Table of Threshold Ranges
26-27	2	TX Power Low Alarm	TX power low alarm threshold	See Table of Threshold Ranges
28-29	2	TX Power High Warning	TX power high warning threshold	See Table of Threshold Ranges

30-31	2	TX Power Low Warning	TX power low warning threshold	See Table of Threshold Ranges
32-33	2	RX Power High Alarm	RX power high alarm threshold	See Table of Threshold Ranges
34-35	2	RX Power Low Alarm	RX power low alarm threshold	See Table of Threshold Ranges
36-37	2	RX Power High Warning	RX power high warning threshold	See Table of Threshold Ranges
38-39	2	RX Power Low Warning	RX power low warning threshold	See Table of Threshold Ranges
40-41	2	Optional Laser Temp High Alarm	This function is not implemented	00 00
42-43	2	Optional Laser Temp Low Alarm	This function is not implemented	00 00
44-45	2	Optional Laser Temp High Warning	This function is not implemented	00 00
46-47	2	Optional Laser Temp Low Warning	This function is not implemented	00 00
48-49	2	Optional TEC Current High Alarm	This function is not implemented	00 00
50-51	2	Optional TEC Current Low Alarm	This function is not implemented	00 00
52-53	2	Optional TEC Current High Warning	This function is not implemented	00 00
54-55	2	Optional TEC Current Low Warning	This function is not implemented	00 00
56-59	4	RX_PWR(4)	External calibration data for RX optical power, the module only implements an internally calibrated function	00 00 00 00

60-63	4	RX_PWR(3)	External calibration data for RX optical power, the module only implements an internally calibrated function	00 00 00 00
64-67	4	RX_PWR(2)	External calibration data for RX optical power, the module only implements an internally calibrated function	00 00 00 00
68-71	4	RX_PWR(1)	External calibration data for RX optical power, the module only implements an internally calibrated function	3F 80 00 00
72-75	4	RX_PWR(0)	External calibration data for RX optical power, the module only implements an internally calibrated function	00 00 00 00
76-77	2	TX_I(Slope)	External calibration data for laser bias current, the module only implements an internally calibrated function	01 00
78-79	2	TX_I(Offset)	External calibration data for laser bias current, the module only implements an internally calibrated function	00 00
80-81	2	TX_PWR(Slope)	External calibration data for TX optical power, the module only implements an internally calibrated function	01 00
82-83	2	TX_PWR(Offset)	External calibration data for TX optical power, the module only implements an internally calibrated function	00 00
84-85	2	T(Slope)	External calibration data for internal module temperature, the module only implements an internally calibrated function	01 00
86-87	2	T(Offset)	External calibration data for internal module temperature, the module only implements an internally calibrated function	00 00
88-89	2	V(Slope)	External calibration data for internal module supply voltage, the module only implements an internally calibrated function	01 00
90-91	2	V(Offset)	External calibration data for internal module supply voltage, the module only implements an internally calibrated function	00 00
92-94	3	Reserved	Reserved	00 00 00
95	1	Checksum	Check sum of bytes 0-94	Defined by vendor
96-97	2	Temperature	Internally measured module temperature, unit is 1/256 °C	Variable

98-99	2	Vcc	Internally measured supply voltage in module, unit is 100 uV	Variable
100-101	2	TX Bias	Internally measured TX bias current, unit is 2 uA	Variable
102-103	2	TX Power	Internally measured TX output power, unit is 0.1 uW	Variable
104-105	2	RX Power	Internally measured RX input power, unit is 0.1 uW	Variable
106-107	2	Optional Laser Temp	This function is not implemented	00 00
108-109	2	Optional TEC current	This function is not implemented	00 00
110	1	Status/Control	BIT7 Tx_Disable input pin state BIT6 = 0 Laser disable control bit. Writing '1' disables laser BIT5 RS1 pin state BIT4 RS0 pin state BIT3 = 0 Soft RS0 control bit. Soft rate select is not implemented BIT2 Tx_Fault pin state BIT1 Rx_LOS pin state BIT0 Data_Ready_Bar state. Zero/low indicates that the module data is ready	Variable
111	1	Reserved	Reserved for SFF-8079	00
112	1	Alarm Flags	BIT7 Temp high alarm flag, active high BIT6 Temp low alarm flag, active high BIT5 Vcc high alarm flag, active high BIT4 Vcc low alarm flag, active high BIT3 TX bias high alarm flag, active high BIT2 TX bias low alarm flag, active high BIT1 TX power high alarm flag, active high BIT0 TX power low alarm, active high	Variable
113	1	Alarm Flags	BIT7 RX power high alarm flag, active high BIT6 RX power Low alarm flag, active high BIT5 Optional laser temp high alarm flag, this alarm flag is not implemented BIT4 Optional laser temp Low alarm flag, this alarm flag is not implemented BIT3 Optional TEC current high alarm flag, this alarm flag is not implemented BIT2 Optional TEC current low alarm flag, this alarm flag is not implemented BIT1:0 Reserved alarm flag	Variable

114	1	Tx input equalization control	<p>BIT7:4 = 0011 High-speed mode input equalization setting value; the default value for power-up is 3, which can be used to change the module input equalization value</p> <p>BIT3:0 = 0010 Low-speed mode input equalization setting value; the default value for power-up is 2, which can be used to change the module output emphasis value</p>	32
115	1	Rx out emphasis Control	<p>BIT7:4 = 0011 High-speed mode output emphasis setting value; the default value for power-up is 3, which can be used to change the module output emphasis value</p> <p>BIT3:0 = 0010 Low-speed mode output emphasis setting value; the default value for power-up is 2, which can be used to change the module output emphasis value</p>	32
116	1	Warning Flags	<p>BIT7 Temp high warning flag, active high</p> <p>BIT6 Temp low warning flag, active high</p> <p>BIT5 Vcc high warning flag, active high</p> <p>BIT4 Vcc low warning flag, active high</p> <p>BIT3 TX Bias high warning flag, active high</p> <p>BIT2 TX bias low warning flag, active high</p> <p>BIT1 TX power high warning flag, active high</p> <p>BIT0 TX power low warning flag, active high</p>	Variable
117	1	Warning Flags	<p>BIT7 RX power high warning flag, active high</p> <p>BIT6 RX power low warning flag, active high</p> <p>BIT5 Optional laser temp high warning flag, this warning flag is not implemented</p> <p>BIT4 Optional laser temp low warning flag, this warning flag is not implemented</p> <p>BIT3 Optional TEC current high warning flag, this warning flag is not implemented</p> <p>BIT2 Optional TEC current low warning flag, this warning flag is not implemented</p> <p>BIT1:0 Reserved warning flag</p>	Variable

118	1	Ext Status/Control	BIT7:4 = 0 Reserved BIT3 = 0 Soft RS1 control bit. Soft rate select is not implemented BIT2 = 0 Reserved BIT1 = 0 Power level state = Level 1, < 1.0 W BIT0 = 0 Power level select = Level 1, < 1.0 W	00
119	1	Ext Status/Control	BIT7:5 = 0 Reserved BIT4 = 0 64GFC Mode Tx configured, this function is not implemented BIT3 = 0 64GFC Mode Rx configured, this function is not implemented BIT2 = 0 64GFC Mode configured, this function is not implemented BIT1 TX CDR state. If the Tx side CDR is enabled, a value of 0 indicates that the CDR is locked, whereas a value of 1 indicates loss of lock of the CDR. If the CDR is in bypass mode, this bit is set to 0 BIT0 RX CDR state. If the Rx side CDR is enabled, a value of 0 indicates that the CDR locked, whereas a value of 1 indicates loss of lock of the CDR. If the CDR is in bypass mode, this bit is set to 0	Variable
120-122	3	Reserved	Reserved	00 00 00
123-126	4	Security Level Password	Security level password entry. The written value can be read back and the default value on power-up is 00 00 00 00(hex)	00 00 00 00
127	1	Page selection byte	Page selection, select A2h high 128 bytes page	00
Upper Memory Map Page 00/01h				
128-255	128	User Writable EEPROM	User defined, readable and writeable under security level 1	Defined by vendor

Block Diagram of Transceiver

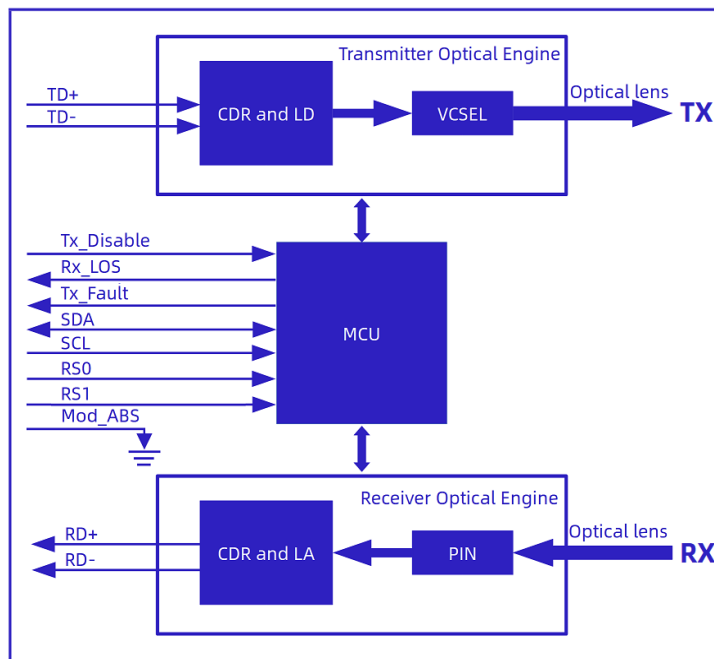

Functions Description

SFP-10/25G-SR-C-D17 module is manufactured by COB (Chip on Board) process and consists of a microcontroller, a transmitter side optical engine and a receiver side optical engine. The module has built-in clock and data recovery functions.

The microcontroller communicates with the host via a 2-wire serial communication interface and provides module control, status reporting, and monitoring (DOM) functions in accordance with the SFF-8472 standard.

The transmitter side optical engine consists of a clock data recovery circuit (CDR), a laser driver circuit (LD), a VCSEL laser, and a monitoring photodiode (MPD). The high-speed differential electrical signals output from the host is restored and shaped by the CDR. The restored electrical signal send to the laser driver and drive the VCSEL lasers to generate optical signals. The optical signals are coupled into the optical fiber through an optical lens. The optical engine integrates a monitoring photodiode for output optical power detection.

The receiver side optical engine consists of a photodiode (PIN), a signal amplifier (TIA/LA) and a receiver clock data recovery circuit (CDR). The optical signal in the optical fiber is coupled through an optical lens to the receiving photodiode (PIN), where it is converted into a photocurrent. The photocurrent signal is amplified by the TIA/LA amplifier, and then sent to the CDR circuit for retiming, and finally transmitted to the host in the form of high-speed differential signal. The microcontroller reads the signal strength (modulation amplitude) received by the photodiode

and reports a loss of the received signal if it is below a set threshold. The receiver detects and reports the Rx_LOS status based on OMA.

Both the transmitter and receiver have the squelch function. When the transmitter side has a signal input, the oscilloscope shows the waveform of the output optical signal as an eye diagram shape, and when there is no signal input, the oscilloscope shows the waveform of the output optical signal as a straight line. When the receiver side has a signal input, the oscilloscope shows the waveform of the output electrical signal as an eye diagram shape, and when there is no signal input, the oscilloscope shows the waveform of the output electrical signal as a straight line.

The SFP-10/25G-SR-C-D17 transceiver supports high data rates 25.78 Gb/s and low data rates 10.31 Gb/s, CDR at transmitter and receiver are configured according to different signal rates.

Dimensions

Module Weight: 16 g

Dust Cap Weight: 1 g

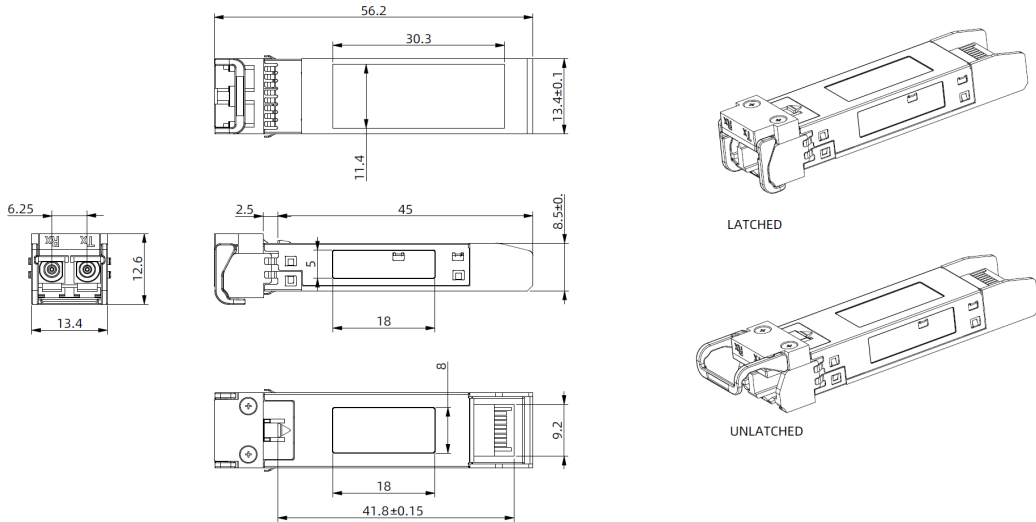

ALL DIMENSIONS ARE ± 0.2 mm UNLESS OTHERWISE SPECIFIED
UNIT: mm

Electrical Pad Layout

Top View of Board

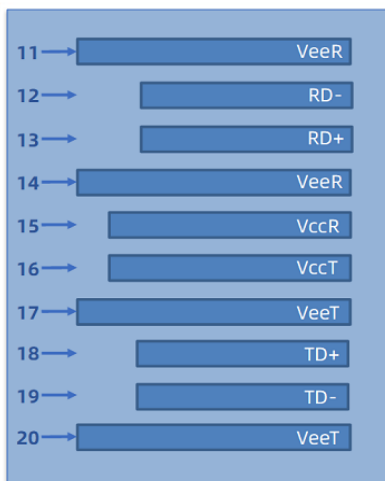

Bottom View of Board

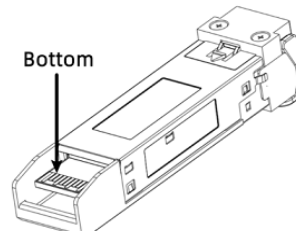
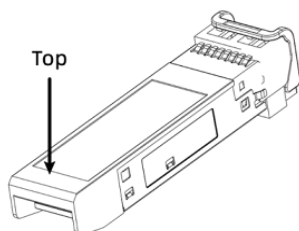
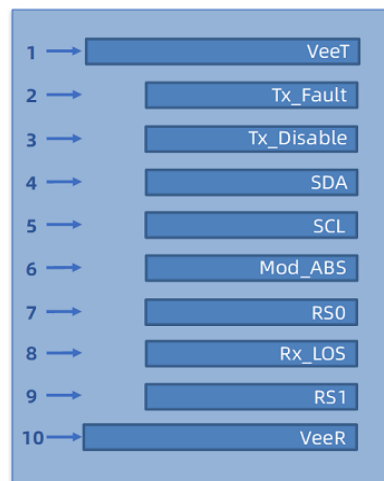

Typical Eye Diagram

Eye View In 25G Working Mode

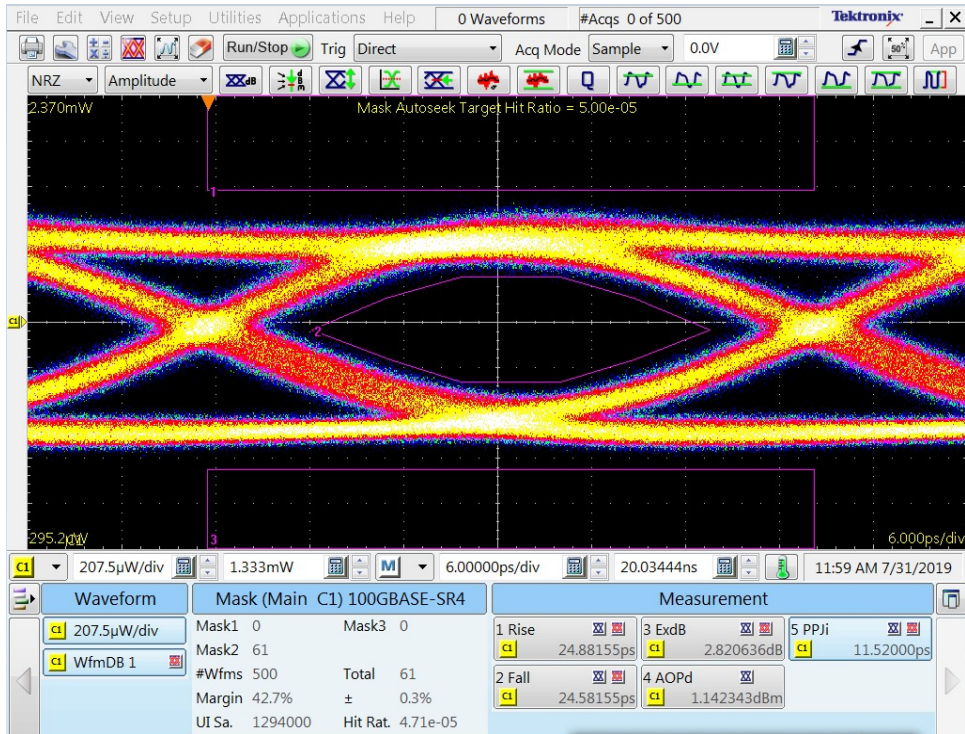

Eye View In 10G Working Mode

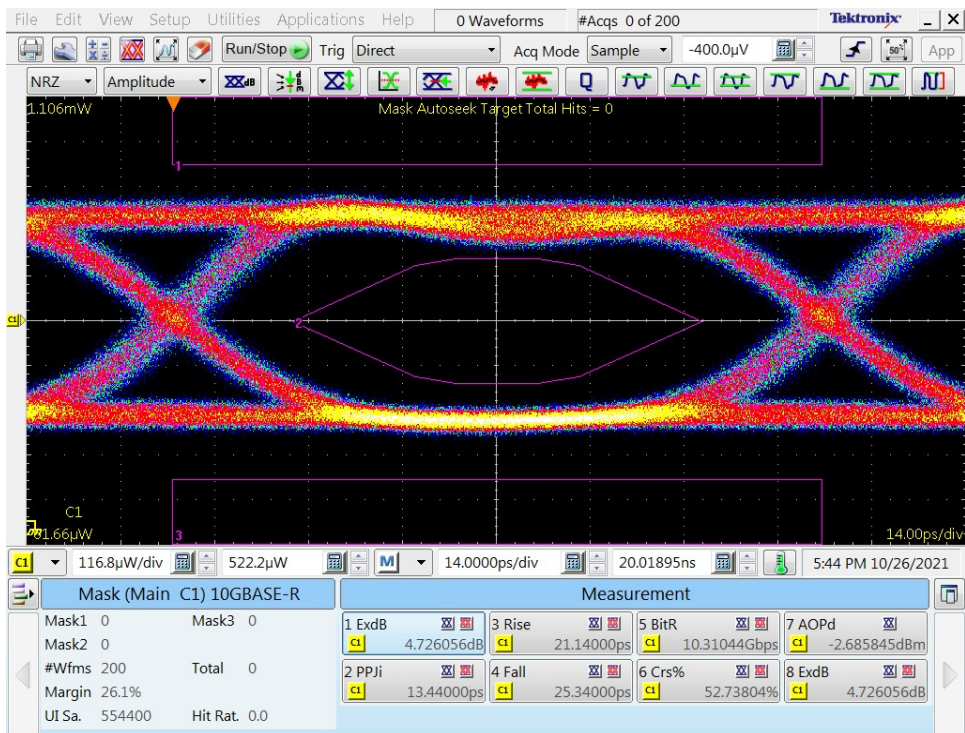

Pin Assignment

PIN #	Symbol	Description	Remarks
1	VeeT	Transmitter ground (common with receiver ground)	1
2	Tx_Fault	Transmitter fault	
3	Tx_Disable	Transmitter disable. Laser output disabled on high or open	2
4	SDA	2-wire serial interface data line	3
5	SCL	2-wire serial interface clock line	3
6	Mod_ABS	Module absent. Grounded within the module	3
7	RS0	No connection required	
8	Rx_LOS	Loss of signal indication. Logic 0 indicates normal operation	4
9	RS1	No connection required	
10	VeeR	Receiver ground (common with transmitter ground)	1
11	VeeR	Receiver ground (common with transmitter ground)	1
12	RD-	Receiver Inverted DATA out. AC coupled	
13	RD+	Receiver Non-inverted DATA out. AC coupled	
14	VeeR	Receiver ground (common with transmitter ground)	1
15	VccR	Receiver power supply	
16	VccT	Transmitter power supply	
17	VeeT	Transmitter ground (common with receiver ground)	1
18	TD+	Transmitter Non-Inverted DATA in. AC coupled	
19	TD-	Transmitter Inverted DATA in. AC coupled	
20	VeeT	Transmitter ground (common with receiver ground)	1

Notes:

1. Circuit ground is internally isolated from case
2. Disabled: $T_{DIS} > 2\text{ V}$ or open, Enabled: $T_{DIS} < 0.8\text{ V}$
3. Should be pulled up on the host board with a 4.7 k Ω to 10 k Ω resistor to a voltage between 2 V and 3.6 V
4. LOS is open collector output

References

1. IEEE standard 802.3
2. SFF-8402 Specification for SFP+ 1X 28 Gb/s Pluggable Transceiver Solution (SFP28)
3. SFF-8472 Specification for Management Interface for SFP+