

DATA SHEET

MODULETEK : DAC-QSFP-4SFP-100G-P-xxAWG-aa.aaM-D1C1B

QSFP to 4SFP 100G Passive Copper Cable Assembly

Overview

ModuleTek's QSFP to 4SFP 100G passive cable is the preferred solution for 100G rate short-range data transmission, it has the characteristics of low power consumption, good stability and high cost performance. The QSFP to 4SFP 100G passive cable is used for data transfer between a 100G QSFP port and four 25G SFP ports, providing a low-cost solution for data transmission services within and between data center racks. The product complies with the QSFP28 MSA and SFP28 MSA standards.

Product Features

- QSFP End: Compliant with QSFP28 MSA specifications
- SFP End: Compliant with SFP28 MSA specifications
- 4 independent duplex channels operating at 25Gbps
- AC coupled inputs and outputs
- 100 Ohm differential impedance
- All-metal housing for superior EMI performance
- Single power supply 3.3V, low power consumption
- RoHS Compliant
- Operating temperature range (Case Temperature):
Commercial Level: 0°C to 70°C

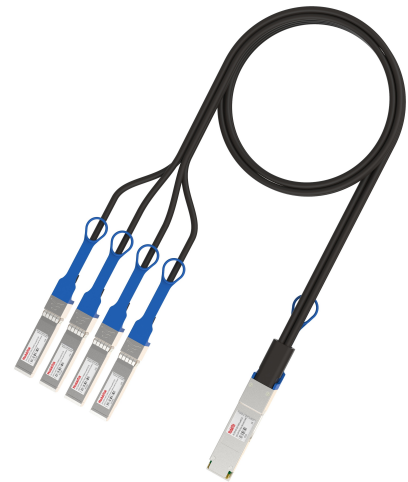

Applications

100Gigabit Ethernet
Serial Data Transmission
Storage
Fiber Channel

Ordering Information

Part Number	Product ID	Description	Gauge	Length
DAC-QSFP-4SFP-100G-P-30AWG-aa.aaM-D1C1B	M600912	QSFP to 4SFP 100G Passive Direct Attach Copper Cable Assembly, aa.aa \leq 2	30AWG	\leq 2m
DAC-QSFP-4SFP-100G-P-28AWG-aa.aaM-D1C1B	M600910	QSFP to 4SFP 100G Passive Direct Attach Copper Cable Assembly, aa.aa \leq 3	28AWG	\leq 3m
DAC-QSFP-4SFP-100G-P-26AWG-aa.aaM-D1C1B	M600911	QSFP to 4SFP 100G Passive Direct Attach Copper Cable Assembly, aa.aa \leq 5	26AWG	\leq 5m
<p>Note:</p> <ol style="list-style-type: none"> "P" indicates passive cable "aa.aa" indicates the cable length in meters. The product with write protection. The wire diameter of the products in the above list is the default value under different lengths. We can also provide other wire products to customers with special requirements. Product ID is the short order number of our product standard model. 				
<p>For More Information: ModuleTek Limited Web: www.moduletek.com Email: sales@moduletek.com</p>				

General Specifications

Parameter	Symbol	Min	Typ	Max	Unit	Remarks
Bit Error Rate	BER			10 ⁻¹²		
Operating Temperature	T _C	0		70	°C	1
Storage Temperature	T _{STO}	-40		85	°C	2
Input Voltage	V _{CC}	3.14	3.3	3.46	V	

Notes:

- Case temperature
- Ambient temperature

I2C Memory Map

QSFP END

Lower Memory Map (A0h)					
IIC Addr	Size	Name	Description	Values (HEX)	Remarks
0	1	Identifier	Description of Physical Device	11	

1-2	2	Status	bit0:Data Not Ready; bit1:Intl; bit2: Flat mem	07 00	
3	1	Channel Status LOS Flag	Latched TX/RX LOS indicator	00	
4	1	Channel Status TxFault Flag	Latched TX fault indicator	00	
5	1	Channel Status Reserved5	Reserved	00	
6	1	Module Monitor Temp AW Flag	Latched temperature alarm/warning and initialization complete	00	
7	1	Module Monitor Vcc AW Flag	Latched Vcc alarm/warning	00	
8	1	Module Monitor Reserved8	Reserved	00	
9-10	2	Channel Mon RxPower AW Flag	Latched Rx Power alarm/warning	00 00	
11-12	2	Channel Mon TxBias AW Flag	Latched Tx Bias alarm/warning	00 00	
13-21	9	Channel Mon Reserved13	Reserved	00	
22-23	2	Module Monitor Temp	Internally measured module temperature	00 00	1
24-25	2	Module Monitor Reserved24	Reserved	0000	
26-27	2	Module Monitor Voltage	Internally measured module supply voltage	00 00	1
28-33	6	Module Monitor Reserved28	Reserved	00	
34-35	2	Channel Mon Rx1Power	Internally measured RX input power, channel 1	00 00	
36-37	2	Channel Mon Rx2Power	Internally measured RX input power, channel 2	00 00	
38-39	2	Channel Mon Rx3Power	Internally measured RX input power, channel 3	00 00	
40-41	2	Channel Mon Rx4Power	Internally measured RX input power, channel 4	00 00	
42-43	2	Channel Mon Tx1Bias	Internally measured TX bias, channel 1	00 00	
44-45	2	Channel Mon Tx2Bias	Internally measured TX bias, channel 2	00 00	
46-47	2	Channel Mon Tx3Bias	Internally measured TX bias, channel 3	00 00	

48-49	2	Channel Mon Tx4Bias	Internally measured TX bias, channel 4	00 00	
50-81	32	Channel Mon Reserved50	Reserved	00	
82-85	4	Reserved82	Reserved	00	
86	1	Control TxDisable	Txn Read/write bit that allows software disable of transmitters	00	
87	1	Control Rx Rate Select	Rx channel Software Rate Select	00	
88	1	Control Tx Rate Select	Tx channel Software Rate Select	00	
89	1	Control Rx4 App Select	Software Application Select per SFF-8079, Rx Channel 4 (Optional)	00	
90	1	Control Rx3 App Select	Software Application Select per SFF-8079, Rx Channel 3 (Optional)	00	
91	1	Control Rx2 App Select	Software Application Select per SFF-8079, Rx Channel 2 (Optional)	00	
92	1	Control Rx1 App Select	Software Application Select per SFF-8079, Rx Channel 1 (Optional)	00	
93	1	Control Power	Power set to low power mode/Override of LPMode signal setting the power mode with software	00	
94	1	Control Tx4 App Select	Software Application Select per SFF-8079, Tx Channel 4 (Optional)	00	
95	1	Control Tx3 App Select	Software Application Select per SFF-8079, Tx Channel 3 (Optional)	00	
96	1	Control Tx2 App Select	Software Application Select per SFF-8079, Tx Channel 2 (Optional)	00	
97	1	Control Tx1 App Select	Software Application Select per SFF-8079, Tx Channel 1 (Optional)	00	
98-99	2	Control Reserved98	Reserved	00 00	
100	1	Mask TxRx LOS	Masking bit for TX/RX LOS indicator	00	

101	1	Mask TxFault	Masking bit for TX fault indicator	00	
102	1	Mask Reserved102	Reserved	00	
103	1	Mask Temp AW	Masking bit for Temperature alarm/warning and initialization complete	00	
104	1	Mask Vcc AW	Masking bit for Vcc alarm/warning	00	
105-106	2	Mask Reserved105	Reserved	00 00	
107-109	3	Reserved107	Reserved	00	
110	1	Power	Power Less Than 1W	08	
111-112	2	Reserved111	Reserved	00	
113	1	Channel	Four Channel	10	
114-118	5	Reserved107	Reserved	00	
119-122	4	Password Change Entry Area	Password Change Entry Area (optional)	00 00 00 00	
123-126	4	Password Entry Area	Password Entry Area (Optional)	00 00 00 00	2
127	1	Page Select	Page Select Byte	00	
Upper Memory Map Page 00h					
IIC Addr	Size	Name	Description	Values (HEX)	Remarks
128	1	Identifier	QSFP28	11	
129	1	Ext. Identifier	CLEI code present in Page 02h	10	
130	1	Connector	No separable connector	23	
131-138	8	Tranceiver	Code for electronic compatibility or optical compatibility	80 00 00 00 00 00 00 00	
139	1	Encoding	(64B66B)	05	
140	1	BR, nominal	Nominal Bit Rate 25.5GB/s	FF	
141	1	Extended RateSelect Compliance	Tags for Extended RateSelect compliance	00	
142	1	Length(SMF)	Link length supported for SMF fiber in km	00	

143	1	Length (E-50µm)	Link length supported for EBW 50/125 µm fiber, units of 2 m	00	
144	1	Length (50 µm)	Link length supported for 50/125 µm fiber, units of 1 m	00	
145	1	Length (62.5 µm)	Link length supported for 62.5/125 µm fiber, units of 1 m	00	
146	1	Length (Copper)	Link length supported for copper, units of 1m	-	
147	1	Device Tech	Copper cable unequalized	A0	
148-163	16	Vendor name	MODULETEK	4D 4F 44 55 4C 45 54 45 4B 20 20 20 20 20 20 20	
164	1	Extended Transceiver	Extended Transceiver Codes for InfiniBand	00	
165-167	3	Vendor OUI	QSFP vendor IEEE company ID	00 00 00	
168-183	16	Vendor PN	Part number in Order information	-	
184-185	2	Vendor rev	Revision level for part number provided by vendor (ASCII)	-	
186-187	2	Wavelength	Nominal laser wavelength (Wavelength = value / 20 in nm)	-	
188-189	2	Wavelength Tolerance	Guaranteed range of laser wavelength (+/- value) from Nominal wavelength.(Wavelength Tol. = value/200 in nm)	-	
190	1	Max Case Temp	Maximum Case Temperature in Degrees C.	46	
191	1	CC BASE	Check code for Base ID Fields (addresses 128-190)	-	
192-195	4	Options	Rate Select, TX Disable, TX Fault, LOS, Warning indicators for: Temperature, VCC, RX power, TX Bias	0B 00 00 00	
196-211	16	Vendor SN	Serial number provided by vendor	Programmed by Factory	

212-219	8	Date Code	Year,Month,Day	Programmed by Factory	
220	1	Diagnostic Monitoring Type	Indicates which types of diagnostic monitoring are implemented (if any) in the Module. Bit 1,0 Reserved	00	
221	1	Enhanced options	Indicates which optional enhanced features are implemented in the Module.	00	
222	1	Reserved	Reserved	-	
223	1	CC EXT	Check code for the Extended ID Fields (addresses 192-222)	-	
224-255	32	Vendor Specific	Vendor Specific EEPROM	-	
Upper Memory Map Page 02h					
IIC Addr	Size	Name	Description	Values (HEX)	Remarks
128-255	128	Upper Memory Map	User Code Area	-	3
Upper Memory Map Page 8Ah					
IIC Addr	Size	Name	Description	Values (HEX)	Remarks
128-131	4	Firmware Version Number[4]	Firmware Version Number	-	
132-135	4	Datasheet Version Number[4]	Datasheet Version Number	-	
136	1	Security Level	Security Level: 00=Normal Mode 01=User Mode(Level 1) 02=Factory Mode(Level 2)	-	
137-138	2	Vcc ADC	Vcc ADC	-	1
139-140	2	Temp ADC	Temp ADC	-	1
Upper Memory Map Page F0h					
IIC Addr	Size	Name	Description	Values (HEX)	Remarks
128-131	4	Password1 long	Level 1 Password	00 00 10 11	

Notes:

- 1.Module automatically updates data
- 2.Default 00000000, read out as last written value

3.Module with write protection, enter the security level 1 writeable

SFP END

Address A0					
IIC Addr	Size	Name	Description	Values (HEX)	Remarks
0	1	Identifier	SFP or SFP+	03	
1	1	Ext. Identifier	GBIC/SFP function is defined by two-wire interface ID only	04	
2	1	Connector	Copper pigtail	21	
3-10	8	Transceiver	Passive Cable	00 00 00 00 00 04 00 00	
11	1	Encoding	Code for high speed serial encoding algorithm	00	
12	1	BR, Nominal	Nominal Bit Rate 25.5GB/s	FF	
13	1	Rate Identifier	Type of rate select functionality	00	
14	1	Length(SMF,km)	Link length supported for single mode fiber, units of km	00	
15	1	Length (SMF)	Link length supported for single mode fiber, units of 100 m	00	
16	1	Length (50um)	Link length supported for 50 um OM2 fiber, units of 10 m	00	
17	1	Length (62.5um)	Link length supported for 62.5 um OM1 fiber, units of 10 m	00	
18	1	Length (OM4 or copper cable)	Link length supported for 50um OM4 fiber, units of 10m. Alternatively copper or direct attach cable, units of m	01	
19	1	Length (OM3)	Link length supported for 50 um OM3 fiber, units of 10 m	00	
20-35	16	Vendor name	MODULETEK	4D 4F 44 55 4C 45 54 45 4B 20 20 20 20 20 20 20	

36	1	Transceiver	Code for electro nic or optical compatibility	0D	
37-39	3	Vendor OUI	SFP vendor IEEE company ID	00 00 00	
40-55	16	Vendor PN	Part number in Order information	-	
56-59	4	Vendor rev	Revision level for part number provided by vendor (ASCII)	-	
60-61	2	Wavelength	Laser wavelength (Passive/Active Cable Specification Compliance)	00 00	
62	1	Unallocated		00	
63	1	CC BASE	Check code for Base ID Fields (addresses 0 to 62)	-	
64-65	2	Options	Indicates which optional transceiver signals are implemented	00 00	
66	1	BR, max	Upper bit rate margin	64	
67	1	BR, min	Lower bit rate margin	00	
68-83	16	Vendor SN	Serial number provided by vendor	Programmed by Factory	
84-91	8	Date code	Year,Month,Day	Programmed by Factory	
92	1	Diagnostic Monitoring Type	Indicates which type of diagnostic monitoring is implemented (if any) in the transceiver	00	
93	1	Enhanced Options	Indicates which optional enhanced features are implemented (if any) in the transceiver	00	
94	1	SFF-8472 Compliance	Indicates which revision of SFF-8472 the transceiver complies with.	00	
95	1	CC EXT	Check code for the Extended ID Fields (addresses 64 to 94)	-	
96-127	32	Vendor Specific	Vendor Specific EEPROM	-	
128-255	128	Vendor Specific	Vendor Specific EEPROM	-	
Address A2 Low					

IIC Addr	Size	Name	Description	Values (HEX)	Remarks
0-94	95	Reserved	Reserved	FF	
95	1	Checksum	0-94 Byte Checksum	-	
96-121	26	Reserved	Reserved	00	
122	1	Security Level	Security Level: 00=Normal Mode; 01=User Mode(Level 1) 02=Factory Mode(Level 2)	00	
123-126	4	Password Entry	Password Entry Area	00 00 00 00	1
127	1	Table Selection	Page Select Byte	00	
Address A2 Page 00h/01h					
IIC Addr	Size	Name	Description	Values (HEX)	Remarks
128-255	128	Upper Memory Map	User Code Area	FF	2
Address A2 Page 8Ah					
IIC Addr	Size	Name	Description	Values (HEX)	Remarks
128-131	4	Firmware Version Number[4]	Firmware Version Number	-	
132-135	4	Total Running Time In Second	Total Running Time In Second	-	
Address A2 Page F0h					
IIC Addr	Size	Name	Description	Values (HEX)	Remarks
128-131	4	Password1 Long	Level 1 Password	00 00 10 11	2
132	1	DisableA0WP	00=A0 With Write Protection; 01=A0 Without Write Protection	00	2
133	1	DisableA2T00T01WP	00=A2 T00T01 With Write Protection; 01=A2 T00T01 Without Write Protection	00	2

Notes:

- 1.Default 00000000, read out as last written value
- 2.Module with write protection, enter the security level 1 writeable

User Mode

Module	Level 1 Default Password	Password Can Be Changed	Permissions
QSFP END	00 00 10 11	YES(A2 TF0)	1. Read And Write A0 T00/T02
			2. Read A0 T8A
			3. Read And Write A0 TF0
SFP END	00 00 10 11	YES(A2 TF0)	1. Read And Write A0
			2. Read And Write A2 T00/T01
			3. Read A2 T8A
			4. Read And Write A2 TF0

Insertion Loss Level

Part Number	Insertion loss level
DAC-QSFP-4SFP-100G-P-30AWG-1M-D1C1B	CA-25G-N
DAC-QSFP-4SFP-100G-P-30AWG-2M-D1C1B	CA-25G-N
DAC-QSFP-4SFP-100G-P-28AWG-2.5M-D1C1B	CA-25G-N
DAC-QSFP-4SFP-100G-P-28AWG-3M-D1C1B	CA-25G-S
DAC-QSFP-4SFP-100G-P-26AWG-5M-D1C1B	CA-25G-L

Note:

1. Cable insertion loss classification standard: IEEE 802.3by 110-10

Typical S parameter

1m 30AWG typical insertion loss curve

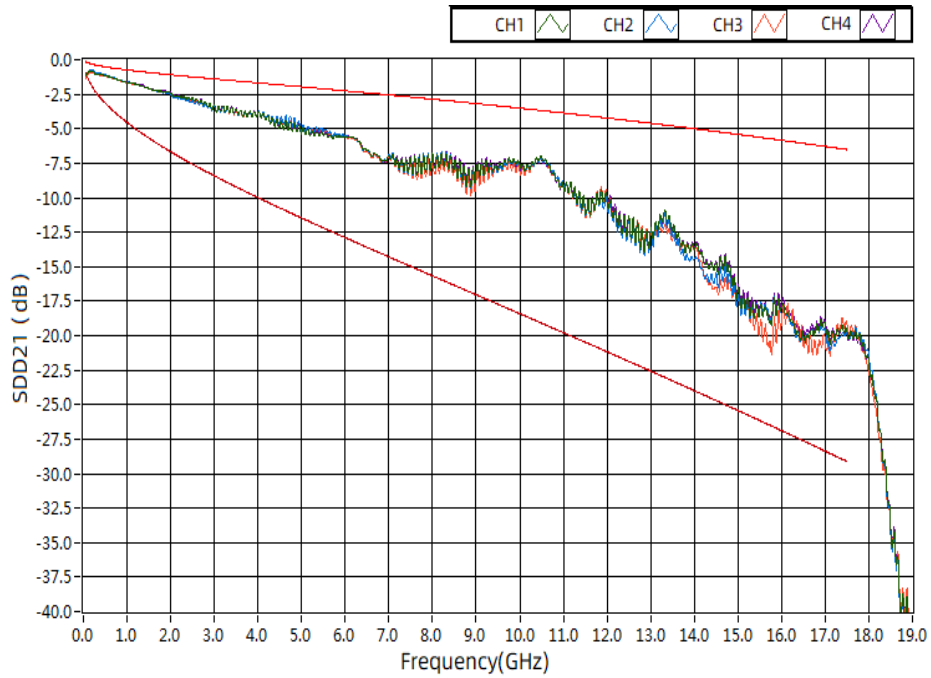

1m 30AWG typical reflection curve

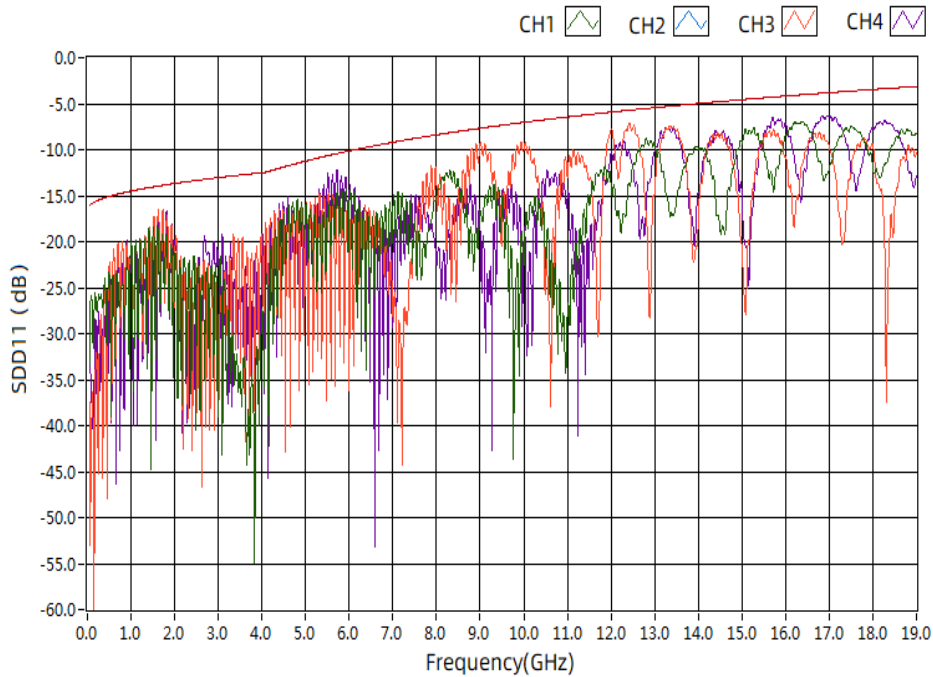

3m 28AWG typical insertion loss curve

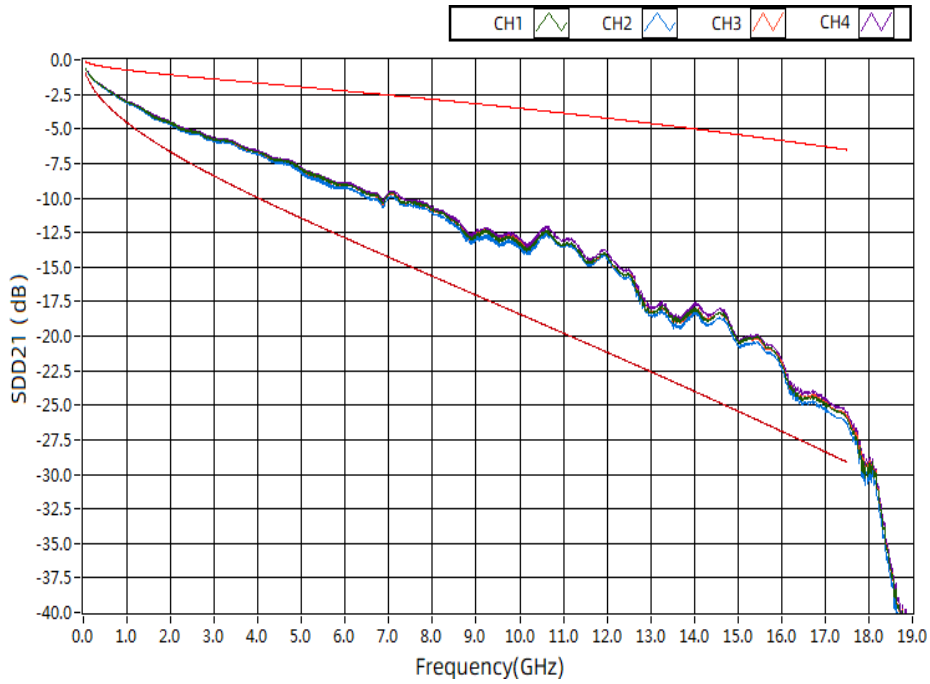

3m 28AWG typical reflection curve

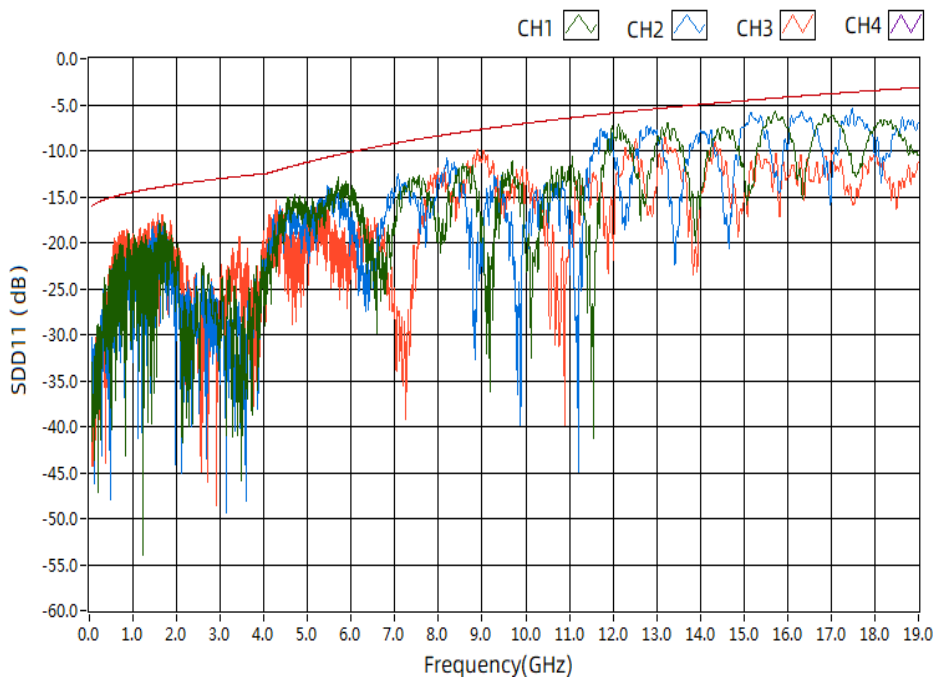

注:

1. Insertion loss standard reference IEEE802.3bj 92.10.2: $IL < 22.48 \text{ dB} @ 12.89 \text{ GHz}$
2. Reflection curve standard reference IEEE802.3bj 92.10.3: $SDD_{xx}(\text{dB}) = 16.5 - 2 \times \text{SQRT}(f)$, $0.05 \leq f < 4.1 \text{ GHz}$.
3. Reflection curve standard reference IEEE802.3bj 92.10.3: $SDD_{xx}(\text{dB}) = 10.66 - 14 \times \log_{10}(f/5.5)$, $4.1 \leq f \leq 19 \text{ GHz}$.

Weight

Parameter	Symbol	Typ	Unit	Remarks
30AWG Product Weight	G _{D30}	270	g/PCS	1
28AWG Product Weight	G _{D28}	290	g/PCS	1
26AWG Product Weight	G _{D26}	320	g/PCS	1
30AWG Cable Weight	G _{C30}	130	g/M	2
28AWG Cable Weight	G _{C28}	155	g/M	2
26AWG Cable Weight	G _{C26}	175	g/M	2
SFP END Dust Cap Weight	G _S	0.80	g/PCS	
QSFP END Dust Cap Weight	G _Q	1.40	g/PCS	

Notes:

- 1.The weight of DAC-QSFP-4SFP-100G-P-xxAWG-1M-D1C1B
- 2.The weight of unit length cable(four sticks). For example: the weight of DAC-QSFP-4SFP-100G-P-26AWG-5M-D1C1B is: $320+175*(5-1)+0.80*4+1.40=1024.6g$

Cable Specifications

Parameter	Symbol	Min	Typ	Max	Unit	Remarks
Wire Gauge		30		26	AWG	
Cable Impedance	Z	90	100	110	Ohm	

Cable Dimension

Serial number	Standard Wire Gauge (AWG)	Cable diameter OD (mm)	Minimum bending radius R (mm)
1	30	4.6	26
2	28	5.0	28

Dimensions

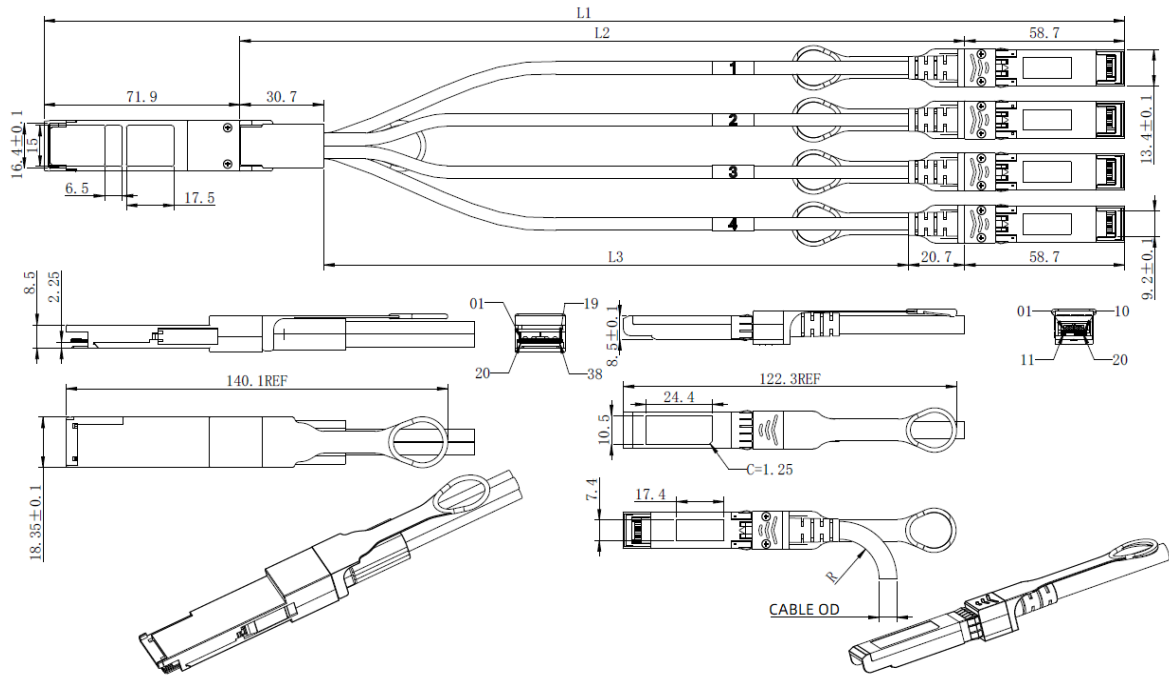

ALL DIMENSIONS ARE ± 0.2 mm UNLESS OTHERWISE SPECIFIED
UNIT: mm

Nominal Length

Serial number	Module nominal length L1 (cm)	Tolerance range \pm (cm)
1	100	2
2	200	2
3	300	4
4	400	4
5	500	6

QSFP Electrical Pad Layout

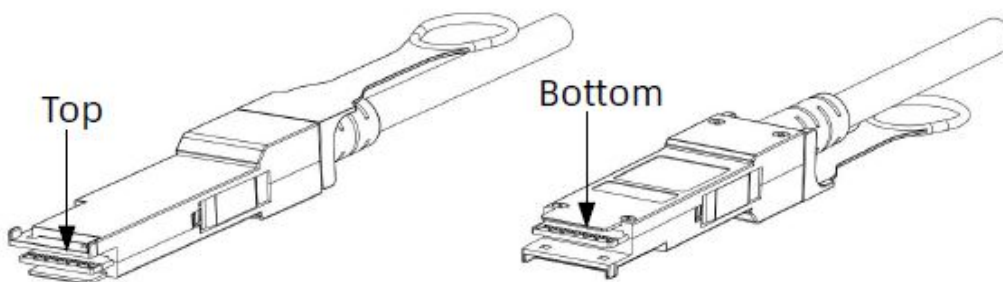
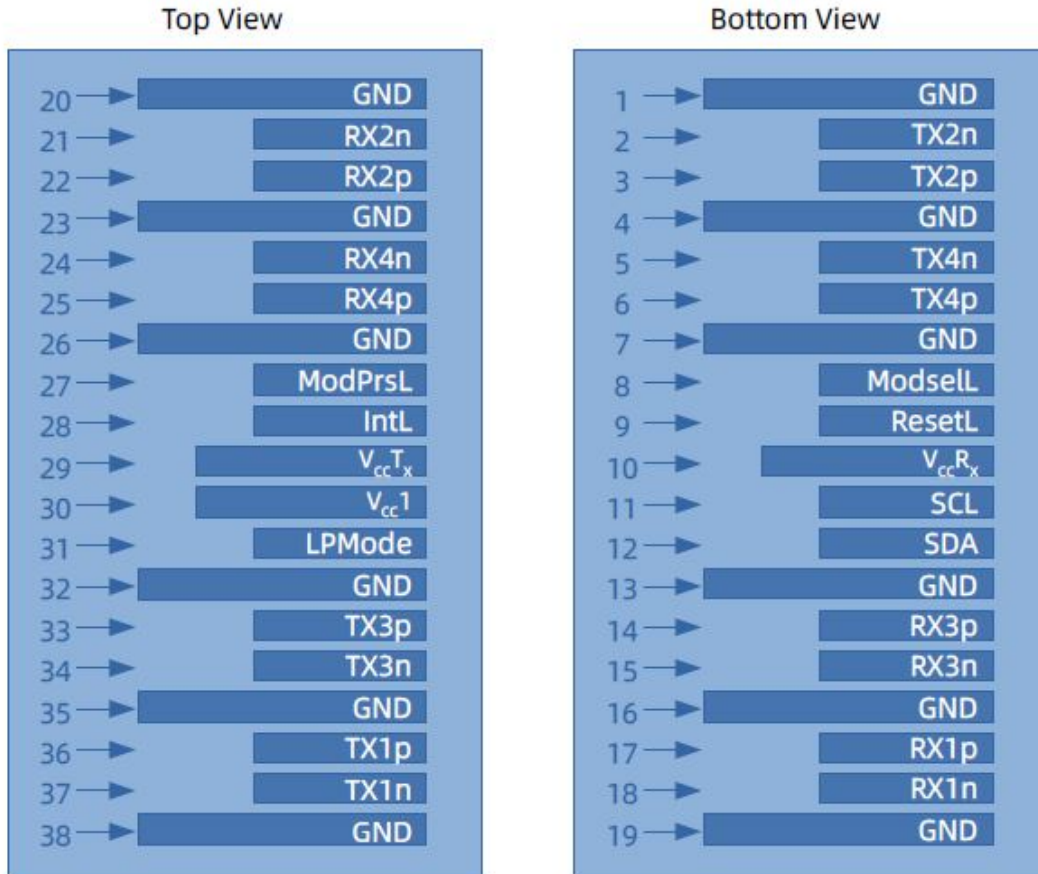

SFP Electrical Pad Layout

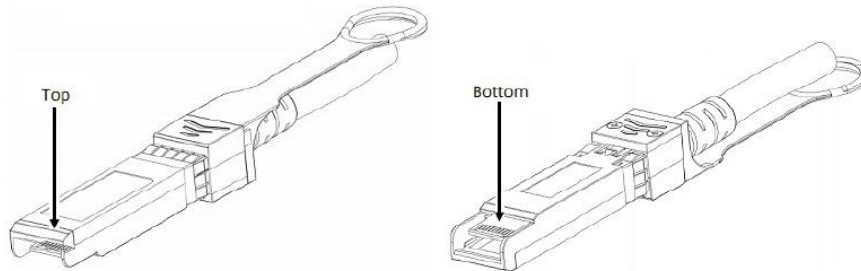
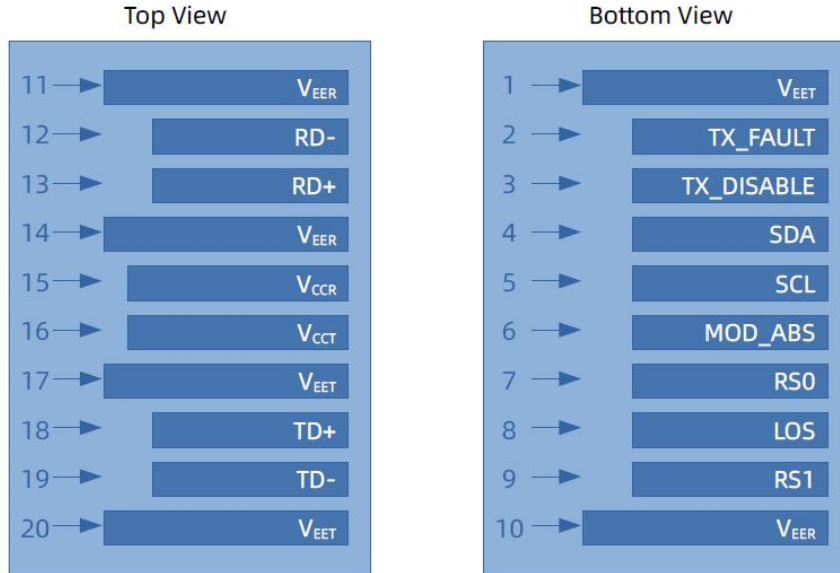

QSFP Pin Assignment

PIN #	Symbol	Description	Remarks
1	GND	Ground	5
2	Tx2n	Transmitter Inverted Data Input, LAN2	
3	Tx2p	Transmitter Non-Inverted Data Input, LAN2	
4	GND	Ground	5
5	Tx4n	Transmitter Inverted Data Input, LAN4	
6	Tx4p	Transmitter Non-Inverted Data Input, LAN4	
7	GND	Ground	5
8	ModSelL	Module select pin, the module responds to two-wire serial communication when low level	1
9	ResetL	Module Reset	2
10	V _{CC} RX	+3.3V Power Supply Receiver	
11	SCL	2-wire serial interface clock	
12	SDA	2-wire serial interface data	
13	GND	Ground	5
14	Rx3p	Receiver Non-Inverted Data Output, LAN3	
15	Rx3n	Receiver Inverted Data Output, LAN3	
16	GND	Ground	5
17	Rx1p	Receiver Non-Inverted Data Output, LAN1	
18	Rx1n	Receiver Inverted Data Output, LAN1	
19	GND	Ground	5
20	GND	Ground	5
21	Rx2n	Receiver Inverted Data Output, LAN2	
22	Rx2p	Receiver Non-Inverted Data Output, LAN2	
23	GND	Ground	5
24	Rx4n	Receiver Inverted Data Output, LAN4	
25	Rx4p	Receiver Non-Inverted Data Output, LAN4	
26	GND	Ground	5
27	ModPrsL	The module is inserted into the indicate pin and grounded in the module.	3
28	IntL	Interrupt	4
29	V _{CC} TX	+3.3V Power Supply transmitter	
30	V _{CC} 1	+3.3V Power Supply	
31	LPMODE	Low Power Mode	5
32	GND	Ground	5

33	Tx3p	Transmitter Non-Inverted Data Input, LAN3	
34	Tx3n	Transmitter Inverted Data Input, LAN3	
35	GND	Ground	5
36	Tx1p	Transmitter Non-Inverted Data Input, LAN1	
37	Tx1n	Transmitter Inverted Data Input, LAN1	
38	GND	Ground	5

Notes:

1. ModSelL is the input pin. The module responds to 2-wire serial communication commands when it is held low by the host. ModSelL allows multiple QSFP modules to be used on a single 2-wire interface bus. If ModSelL is High, the module will not respond to any 2-wire interface communication from the host. ModSelL has internal pull-up resistors in the module
2. The module restart pin, when the low level on the ResetL pin lasts longer than the minimum pulse length, resets the module and restores all user modules to their default state. When performing reset device, the host should ignore all status bits. Until the module reset interrupt is completed, please note that during hot plugging, the module will issue this information to complete the reset interrupt without resetting
3. This pin is active high, indicating that the module is running under a low power module. The signal has no effect on the functionality of this product.
4. IntL is the output pin, which is the open collector output and must be pulled up to Vcc with a 4.7kΩ-10kΩ resistor on the motherboard. When it is low, it indicates that the module may malfunction. The host uses a 2-wire serial interface to identify the interrupt source
5. Circuit ground is internally isolated from chassis ground.

SFP Pin Assignment

PIN #	Symbol	Description	Remarks
1	V _{EET}	Transmitter ground (common with receiver ground)	1
2	TX_FAULT	Transmitter failure alarm, not used	
3	TX_DISABLE	The signal turns off the module transmitter when it is high or open, not used.	
4	SDA	Data line for serial ID	2
5	SCL	Clock line for serial ID	2
6	MOD_ABS	Module Absent. Grounded within the module	2
7	RS0	No connection required	
8	LOS	Loss of Signal indication. Logic 0 indicates normal operation	
9	RS1	No connection required	
10	V _{EER}	Receiver ground (common with transmitter ground)	1
11	V _{EER}	Receiver ground (common with transmitter ground)	1
12	RD-	Receiver Inverted DATA out. AC coupled	
13	RD+	Receiver Non-inverted DATA out. AC coupled	
14	V _{EER}	Receiver ground (common with transmitter ground)	1
15	V _{CCR}	Receiver power supply	
16	V _{CCT}	Transmitter power supply	
17	V _{EET}	Transmitter ground (common with receiver ground)	1
18	TD+	Transmitter Non-Inverted DATA in. AC coupled	
19	TD-	Transmitter Inverted DATA in. AC coupled	
20	V _{EET}	Transmitter ground (common with receiver ground)	1

Notes:

1. Circuit ground is isolated from chassis ground
2. Should Be pulled up with 4.7k - 10k ohm on host board to a voltage between 2V and 3.6V

References

1. IEEE standard 802.3bj. IEEE Standard Department.
2. IEEE standard 802.3by. IEEE Standard Department.