

DATA SHEET

MODULETEK: DAC-QSFP-40G-A-xxAWG-aa.aaM-D0D0B

QSFP 40G Active Copper Cable Assembly

Overview

ModuleTek's 40G active direct-attach copper cables are suitable for very short distances and offer a highly cost-effective way to establish a 40-Gigabit link between QSFP ports. QSFP+ are designed for a high density cabling interconnect system capable of delivering an aggregate data bandwidth of 40Gbps. This interconnect system is fully compliant with QSFP+ MSA. The QSFP+ cables support the bandwidth transmission requirements defined by IEEE802.3ba (40Gbps).

Product Features

- Up to 40 Gb/s bi-directional data links
- Compliant with QSFP+ MSA specifications
- Compliant with IEEE802.3ba specifications
- Compliant with Infiniband QDR specifications
- 4 independent duplex channels operating at 10Gbps
- Support for 2.5Gbps,5Gbps data rates
- All-metal housing for superior EMI performance
- Single power supply 3.3V
- Low power consumption, less than 1.5W
- RoHS Compliant
- Operating temperature range: 0°C to 70°C



Applications

40Gigabit Ethernet
Serial Data Transmission
QDR

Ordering Information

Part Number	Product ID	Description	Gauge	Length
DAC-QSFP-40G-A-xxAWG-aa.aaM-D0D0B	M365803	QSFP 40G Active Copper Cable Assembly, aa.aa≤7	30AWG	≤7m
DAC-QSFP-40G-A-xxAWG-aa.aaM-D0D0B	M310803	QSFP 40G Active Copper Cable Assembly, aa.aa≤10	28AWG	≤10m
Note: 1. "A" indicates active cable 2. "aa.aa" indicates the cable length in meters. 3. The product with write protection. 4. The wire diameter of the products in the above list is the default value under different lengths. We can also provide other wire products to customers with special requirements. 5. Product ID is the short order number of our product standard model.				
For More Information: ModuleTek Limited Web: www.moduletek.com Email: sales@moduletek.com				

General Specifications

Parameter	Symbol	Min	Typ	Max	Unit	Remarks
Bit Error Rate	BER			10 ⁻¹²		
Operating Temperature	T _C	0		70	°C	1
Storage Temperature	T _{STO}	-40		85	°C	2
Input Voltage	V _{CC}	3.14	3.3	3.46	V	
Total Power Consumption	P		1.23	1.32	W	

Notes:

- 1.Case temperature
- 2.Ambient temperature

I2C Memory Map

Lower Memory Map (A0h)					
IIC Addr	Size	Name	Description	Values (HEX)	Remarks
0	1	Identifier	QSFP+	0D	
1-2	2	Status	bit0:Data Not Ready; bit1:IntL; bit2: Flat mem	00 00	

3	1	Channel Status LOS Flag	Latched TX/RX LOS indicator	00	
4	1	Channel Status TxFault Flag	Latched TX fault indicator	00	
5	1	Channel Status Reserved5	Reserved	00	
6	1	Module Monitor Temp AW Flag	Latched temperature alarm/warning and initialization complete	00	
7	1	Module Monitor Vcc AW Flag	Latched Vcc alarm/warning	00	
8	1	Module Monitor Reserved8	Reserved	00	
9-10	2	Channel Mon RxPower AW Flag	Latched Rx Power alarm/warning	00 00	
11-12	2	Channel Mon TxBias AW Flag	Latched Tx Bias alarm/warning	00 00	
13-21	9	Channel Mon Reserved13	Reserved	00	
22-23	2	Module Monitor Temp	Internally measured module temperature	-	
24-25	2	Module Monitor Reserved24	Reserved	00 00	
26-27	2	Module Monitor Voltage	Internally measured module supply voltage	-	
28-33	6	Module Monitor Reserved28	Reserved	00	
34-35	2	Channel Mon Rx1Power	Internally measured RX input power, channel 1	00 00	
36-37	2	Channel Mon Rx2Power	Internally measured RX input power, channel 2	00 00	
38-39	2	Channel Mon Rx3Power	Internally measured RX input power, channel 3	00 00	
40-41	2	Channel Mon Rx4Power	Internally measured RX input power, channel 4	00 00	
42-43	2	Channel Mon Tx1Bias	Internally measured TX bias, channel 1	00 00	
44-45	2	Channel Mon Tx2Bias	Internally measured TX bias, channel 2	00 00	
46-47	2	Channel Mon Tx3Bias	Internally measured TX bias, channel 3	00 00	
48-49	2	Channel Mon Tx4Bias	Internally measured TX bias, channel 4	00 00	

50-81	32	Channel Mon Reserved50	Reserved	00	
82-85	4	Reserved82	Reserved	00	
86	1	Control TxDisable	Txn Read/write bit that allows software disable of transmitters	00	
87	1	Control Rx Rate Select	Rx channel Software Rate Select	00	
88	1	Control Tx Rate Select	Tx channel Software Rate Select	00	
89	1	Control Rx4 App Select	Software Application Select per SFF-8079, Rx Channel 4 (Optional)	00	
90	1	Control Rx3 App Select	Software Application Select per SFF-8079, Rx Channel 3 (Optional)	00	
91	1	Control Rx2 App Select	Software Application Select per SFF-8079, Rx Channel 2 (Optional)	00	
92	1	Control Rx1 App Select	Software Application Select per SFF-8079, Rx Channel 1 (Optional)	00	
93	1	Control Power	Power set to low power mode/Override of LPMode signal setting the power mode with software	00	
94	1	Control Tx4 App Select	Software Application Select per SFF-8079, Tx Channel 4 (Optional)	00	
95	1	Control Tx3 App Select	Software Application Select per SFF-8079, Tx Channel 3 (Optional)	00	
96	1	Control Tx2 App Select	Software Application Select per SFF-8079, Tx Channel 2 (Optional)	00	
97	1	Control Tx1 App Select	Software Application Select per SFF-8079, Tx Channel 1 (Optional)	00	
98-99	2	Control Reserved98	Reserved	00 00	
100	1	Mask TxRx LOS	Masking bit for TX/RX LOS indicator	00	
101	1	Mask TxFault	Masking bit for TX fault indicator	00	

102	1	Mask Reserved102	Reserved	00	
103	1	Mask Temp AW	Masking bit for Temperature alarm/warning and initialization complete	00	
104	1	Mask Vcc AW	Masking bit for Vcc alarm/warning	00	
105-106	2	Mask Reserved105	Reserved	00 00	
107-118	12	Reserved107	Reserved	00	
119-122	4	Password Change Entry Area	Password Change Entry Area	00 00 00 00	1
123-126	4	Password Entry Area	Password Entry Area	00 00 00 00	2
127	1	Page Select	Page Select Byte	00	
Upper Memory Map Page 00h					
IIC Addr	Size	Name	Description	Values (HEX)	Remarks
128	1	Identifier	QSFP+	0D	
129	1	Ext. Identifier	Extended Identifier of Serial Module	00	
130	1	Connector	No separable connector	23	
131-138	8	Tranceiver	40G Active Cable	00 00 00 00 00 00 00 00	
139	1	Encoding	(64B66B)	05	
140	1	BR, nominal	Nominal Bit Rate 10.3Gb/s	67	
141	1	Extended RateSelect Compliance	Tags for Extended RateSelect compliance	00	
142	1	Length(SMF)	Link length supported for SMF fiber in km	00	
143	1	Length (E-50µm)	Link length supported for EBW 50/125 µm fiber, units of 2 m	00	
144	1	Length (50 µm)	Link length supported for 50/125 µm fiber, units of 1 m	00	
145	1	Length (62.5 µm)	Link length supported for 62.5/125 µm fiber, units of 1 m	00	
146	1	Length (Copper)	Link length supported for copper, units of 1m	-	

147	1	Device Tech	Copper cable unequalized	A0	
148-163	16	Vendor name	MODULETEK	4D 4F 44 55 4C 45 54 45 4B 20 20 20 20 20 20 20	
164	1	Extended Transceiver	Extended Transceiver Codes for InfiniBand	00	
165-167	3	Vendor OUI	QSFP vendor IEEE company ID	00 00 00	
168-183	16	Vendor PN	Part number in Order information	-	
184-185	2	Vendor rev	Revision level for part number provided by vendor (ASCII)	-	
186-187	2	Wavelength	Nominal laser wavelength (Wavelength = value / 20 in nm)	-	
188-189	2	Wavelength Tolerance	Guaranteed range of laser wavelength (+/- value) from Nominal wavelength.(Wavelength Tol. = value/200 in nm)	-	
190	1	Max Case Temp	Maximum case temperature in degrees C(70°C)	46	
191	1	CC BASE	Check code for Base ID Fields (addresses 128-190)	-	
192-195	4	Options	Rate Select, TX Disable, TX Fault, LOS, Warning indicators for: Temperature, VCC, RX power, TX Bias	0B 00 00 00	
196-211	16	Vendor SN	Serial number provided by vendor	Programmed by Factory	
212-219	8	Date Code	Year,Month,Day	Programmed by Factory	
220	1	Diagnostic Monitoring Type	Indicates which types of diagnostic monitoring are implemented (if any) in the Module. Bit 1,0 Reserved	2E	
221	1	Enhanced options	Indicates which optional enhanced features are implemented in the Module.	00	

222	1	Reserved	Reserved	-	
223	1	CC EXT	Check code for the Extended ID Fields (addresses 192-222)	-	
224-255	32	Vendor Specific	Vendor Specific EEPROM	-	
Upper Memory Map Page 02h					
IIC Addr	Size	Name	Description	Values (HEX)	Remarks
128-255	128	Upper Memory Map	User Code Area	-	
Upper Memory Map Page 03h					
IIC Addr	Size	Name	Description	Values (HEX)	Remarks
128-129	2	Temp High Alarm	80°C	50 00	
130-131	2	Temp Low Alarm	-10°C	F6 00	
132-133	2	Temp High Warning	75°C	4B 00	
134-135	2	Temp Low Warning	-5°C	FB 00	
136-143	8	Reserved136	Reserved	00	
144-145	2	Vcc High Alarm	3.63V	8D CC	
146-147	2	Vcc Low Alarm	2.97V	74 04	
148-149	2	Vcc High Warning	3.46V	87 28	
150-151	2	Vcc Low Warning	3.13V	7A 44	
152-175	24	Reserved152	Reserved	00	
176-177	2	RX Power High Alarm	RX Power High Alarm	00 00	
178-179	2	RX Power Low Alarm	RX Power Low Alarm	00 00	
180-181	2	RX Power High Warning	RX Power High Warning	00 00	
182-183	2	RX Power Low Warning	RX Power Low Warning	00 00	
184-185	2	TX Bias High Alarm	TX Bias High Alarm	00 00	
186-187	2	TX Bias Low Alarm	TX Bias Low Alarm	00 00	
188-189	2	TX Bias High Warning	TX Bias High Warning	00 00	
190-191	2	TX Bias Low Warning	TX Bias Low Warning	00 00	
192-225	34	Reserved192	Reserved	00	

226-237	12	Vendor Channel Controls	Vendor Specific Channel Controls	00	
238	1	RX12 Output Amplitude	RX1/RX2 Output amplitude levels	00	
239	1	RX34 Output Amplitude	RX3/RX4 Output amplitude levels	00	
240	1	TxRx SQ Disable	Optional Channel Controls, Tx/Rx Squelch Disable	00	
241	1	Rx Output Disable	Optional Channel Controls, Rx Output Disable		
242-243	2	Rx Power AW Mask	Masking bit for RX Power alarm/warning	00 00	
244-245	2	Tx Bias AW Mask	Masking bit for TX Bias alarm/warning	00 00	
246-255	10	Reserved246	Reserved	00	

Notes:

- 1.The ability to change password can be implemented
- 2.Password entry area are write-only bits, read out always 00000000
- 3.Page 00 and page 02 with write protection, enter the security level 1 writeable

User Mode

Level 1 Default Password	Password Can Be Changed	Permissions
00 00 10 11	YES	1. Change PAassword (77h-7Ah) 2. Read And Write A0 T00/T02

Cable Specifications

Parameter	Symbol	Min	Typ	Max	Unit	Remarks
Wire Gauge		30		28	AWG	
Cable Impedance	Z	90	100	110	Ohm	

Block Diagram of Transceiver

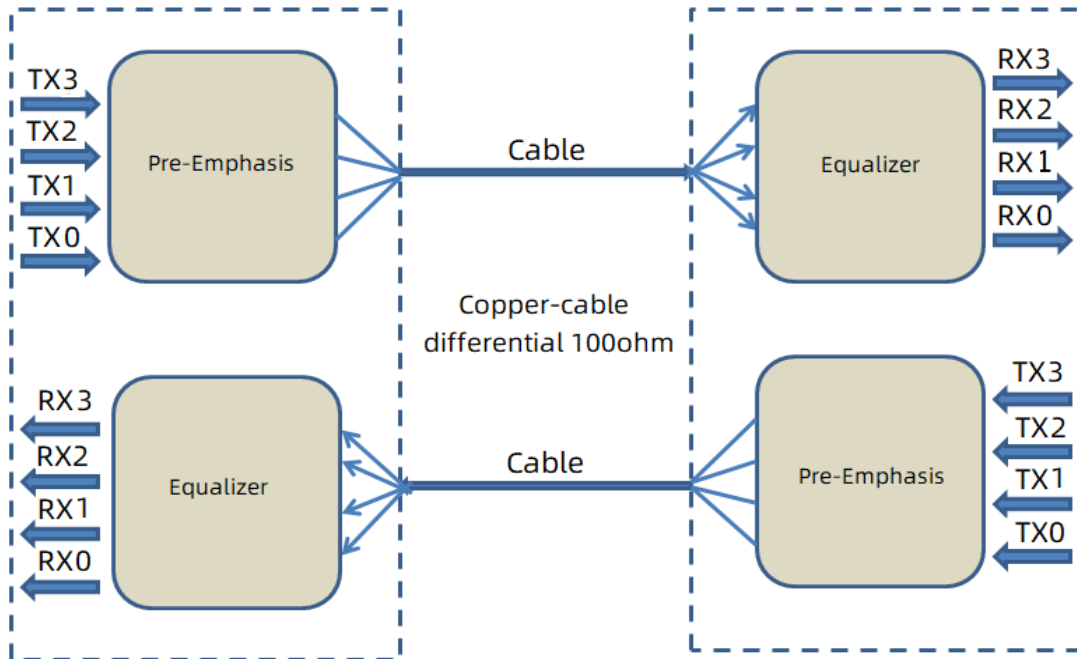

Weight

Parameter	Symbol	Typ	Unit	Remarks
30AWG Product Weight	G_{D30}	140	g/PCS	1
28AWG Product Weight	G_{D28}	160	g/PCS	1
30AWG Cable Weight	G_{C30}	62	g/M	
28AWG Cable Weight	G_{C28}	76	g/M	
Dust Cap Weight	G_Q	1.40	g/PCS	

Notes:

1.The weight of DAC-QSFP-40G-A-xxAWG-1M-D0D0B.For example:The weight of DAC-QSFP-40G-A-28AWG-10M-D0D0B is: $160+76*(10-1)+1.40*2=846.8g$

Dimensions

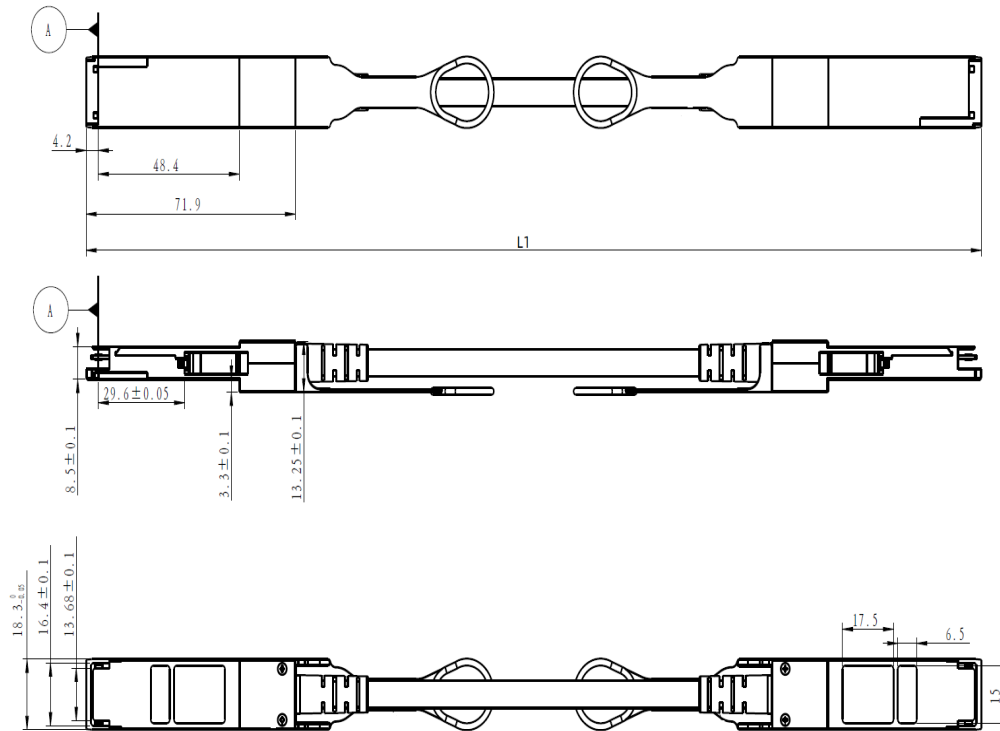

ALL DIMENSIONS ARE ± 0.2 mm UNLESS OTHERWISE SPECIFIED
UNIT: mm

Length tolerance

Serial number	Nominal length L_1 (m)	Tolerance range \pm (cm)
1	$L_1 \leq 2$	2
2	$2 < L_1 \leq 4$	4
3	$4 < L_1 \leq 6$	6
4	$6 < L_1$	8

QSFP Electrical Pad Layout

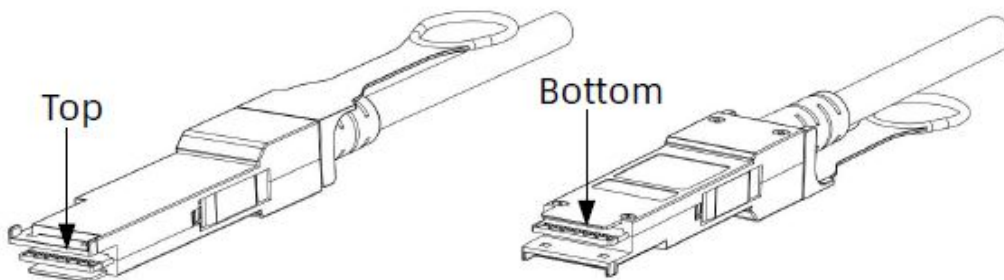
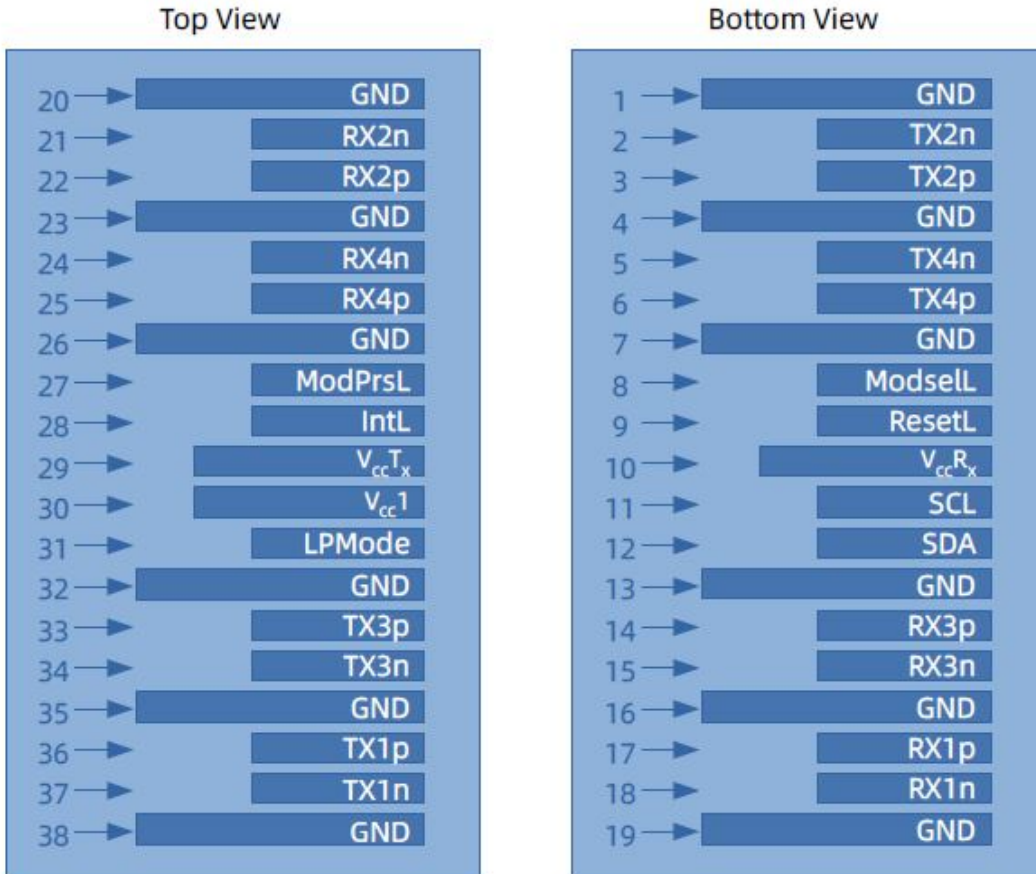

QSFP Pin Assignment

PIN #	Symbol	Description	Remarks
1	GND	Ground	5
2	Tx2n	Transmitter Inverted Data Input, LAN2	
3	Tx2p	Transmitter Non-Inverted Data Input, LAN2	
4	GND	Ground	5
5	Tx4n	Transmitter Inverted Data Input, LAN4	
6	Tx4p	Transmitter Non-Inverted Data Input, LAN4	
7	GND	Ground	5
8	ModSelL	Module select pin, the module responds to two-wire serial communication when low level	1
9	ResetL	Module Reset	2
10	V _{cc} R _X	+3.3V Power Supply Receiver	
11	SCL	2-wire serial interface clock	
12	SDA	2-wire serial interface data	
13	GND	Ground	5
14	Rx3p	Receiver Non-Inverted Data Output, LAN3	
15	Rx3n	Receiver Inverted Data Output, LAN3	
16	GND	Ground	5
17	Rx1p	Receiver Non-Inverted Data Output, LAN1	
18	Rx1n	Receiver Inverted Data Output, LAN1	
19	GND	Ground	5
20	GND	Ground	5
21	Rx2n	Receiver Inverted Data Output, LAN2	
22	Rx2p	Receiver Non-Inverted Data Output, LAN2	
23	GND	Ground	5
24	Rx4n	Receiver Inverted Data Output, LAN4	
25	Rx4p	Receiver Non-Inverted Data Output, LAN4	
26	GND	Ground	5
27	ModPrsL	The module is inserted into the indicate pin and grounded in the module.	3
28	IntL	Interrupt	4
29	V _{cc} T _X	+3.3V Power Supply transmitter	
30	V _{cc} 1	+3.3V Power Supply	
31	LPMoDe	Low Power Mode	5
32	GND	Ground	5

33	Tx3p	Transmitter Non-Inverted Data Input, LAN3	
34	Tx3n	Transmitter Inverted Data Input, LAN3	
35	GND	Ground	5
36	Tx1p	Transmitter Non-Inverted Data Input, LAN1	
37	Tx1n	Transmitter Inverted Data Input, LAN1	
38	GND	Ground	5

Notes:

1. ModSelL is the input pin. The module responds to 2-wire serial communication commands when it is held low by the host. ModSelL allows multiple QSFP modules to be used on a single 2-wire interface bus. If ModSelL is High, the module will not respond to any 2-wire interface communication from the host. ModSelL has internal pull-up resistors in the module
2. The module restart pin, when the low level on the ResetL pin lasts longer than the minimum pulse length, resets the module and restores all user modules to their default state. When performing reset device, the host should ignore all status bits. Until the module reset interrupt is completed, please note that during hot plugging, the module will issue this information to complete the reset interrupt without resetting
3. This pin is active high, indicating that the module is running under a low power module.
4. IntL is the output pin, which is the open collector output and must be pulled up to Vcc on the motherboard. When it is low, it indicates that the module may malfunction. The host uses a 2-wire serial interface to identify the interrupt source
5. Circuit ground is internally isolated from chassis ground.

References

1. IEEE standard 802.3ba. IEEE Standard Department.