

DATA SHEET

MODULETEK: DAC-QSFP-2QSFP-100G-P-xxAWG-aa.aaM-D1D1D

QSFP to 2QSFP 100G Passive Copper Cable Assembly

Overview

ModuleTek's QSFP to 2QSFP 100G passive cable is a high speed, cost-effective, 100Gbps to 2x50Gbps, ethernet connectivity solution designed to meet the growing needs for higher bandwidth in data centers. Cables provide connectivity between systems using a QSFP port one side and two QSFP ports on the other. This interconnect system is compliant with SFF-8665.

Product Features

- Compliant with SFF-8665 specifications
- 2 independent duplex channels operating at 50Gbps
- Single power supply 3.3V
- BER better than 1E-15
- Hot pluggable
- RoHS Compliant
- Operating temperature range (Case Temperature):
Commercial Level: 0°C to 70°C



Applications

100Gigabit Ethernet
Fiber Channel

Ordering Information

Part Number	Product ID	Description	Gauge	Length
DAC-QSFP-2QSFP-100G-P-30AWG-aa.aaM-D1D1D	M254801	QSFP to 2QSFP 100G Passive Direct Attach Copper Cable Assembly	30AWG	≤3m
DAC-QSFP-2QSFP-100G-P-26AWG-aa.aaM-D1D1D	M009501	QSFP to 2QSFP 100G Passive Direct Attach Copper Cable Assembly	26AWG	≤5m
<p>Note:</p> <ol style="list-style-type: none"> 1. "P" indicates passive cable 2. "aa.aa" indicates the cable length in meters. 3. The product with write protection. 4. The wire diameter of the products in the above list is the default value under different lengths. We can also provide other wire products to customers with special requirements. 5. Product ID is the short order number of our product standard model. 				
<p>For More Information: ModuleTek Limited Web: www.moduletek.com Email: sales@moduletek.com</p>				

General Specifications

Parameter	Symbol	Min	Typ	Max	Unit	Remarks
Bit Error Rate	BER			10 ⁻¹²		
Operating Temperature	T _C	0		70	°C	1
Storage Temperature	T _{STO}	-40		85	°C	2
Input Voltage	V _{CC}	3.14	3.3	3.46	V	

Notes:

1. Case temperature
2. Ambient temperature

I2C Memory Map

Lower Memory Map (A0h)					
IIC Addr	Size	Name	Description	Values (HEX)	Remarks
0	1	Identifier	QSFP28	11	
1-2	2	Status	bit0:Data Not Ready; bit1:IntL; bit2: Flat mem	07 00	
3	1	Channel Status LOS Flag	Latched TX/RX LOS indicator	00	

4	1	Channel Status TxFault Flag	Latched TX fault indicator	00	
5	1	Channel Status Reserved5	Reserved	00	
6	1	Module Monitor Temp AW Flag	Latched temperature alarm/warning and initialization complete	00	
7	1	Module Monitor Vcc AW Flag	Latched Vcc alarm/warning	00	
8	1	Module Monitor Reserved8	Reserved	00	
9-10	2	Channel Mon RxPower AW Flag	Latched Rx Power alarm/warning	00 00	
11-12	2	Channel Mon TxBias AW Flag	Latched Tx Bias alarm/warning	00 00	
13-21	9	Channel Mon Reserved13	Reserved	00	
22-23	2	Module Monitor Temp	Internally measured module temperature	00 00	
24-25	2	Module Monitor Reserved24	Reserved	00 00	
26-27	2	Module Monitor Voltage	Internally measured module supply voltage	00 00	
28-33	6	Module Monitor Reserved28	Reserved	00	
34-35	2	Channel Mon Rx1Power	Internally measured RX input power, channel 1	00 00	
36-37	2	Channel Mon Rx2Power	Internally measured RX input power, channel 2	00 00	
38-39	2	Channel Mon Rx3Power	Internally measured RX input power, channel 3	00 00	
40-41	2	Channel Mon Rx4Power	Internally measured RX input power, channel 4	00 00	
42-43	2	Channel Mon Tx1Bias	Internally measured TX bias, channel 1	00 00	
44-45	2	Channel Mon Tx2Bias	Internally measured TX bias, channel 2	00 00	
46-47	2	Channel Mon Tx3Bias	Internally measured TX bias, channel 3	00 00	
48-49	2	Channel Mon Tx4Bias	Internally measured TX bias, channel 4	00 00	
50-81	32	Channel Mon Reserved50	Reserved	00	

82-85	4	Reserved82	Reserved	00	
86	1	Control TxDisable	Txn Read/write bit that allows software disable of transmitters	00	
87	1	Control Rx Rate Select	Rx channel Software Rate Select	00	
88	1	Control Tx Rate Select	Tx channel Software Rate Select	00	
89	1	Control Rx4 App Select	Software Application Select per SFF-8079, Rx Channel 4 (Optional)	00	
90	1	Control Rx3 App Select	Software Application Select per SFF-8079, Rx Channel 3 (Optional)	00	
91	1	Control Rx2 App Select	Software Application Select per SFF-8079, Rx Channel 2 (Optional)	00	
92	1	Control Rx1 App Select	Software Application Select per SFF-8079, Rx Channel 1 (Optional)	00	
93	1	Control Power	Power set to low power mode/Override of LPMODE signal setting the power mode with software	00	
94	1	Control Tx4 App Select	Software Application Select per SFF-8079, Tx Channel 4 (Optional)	00	
95	1	Control Tx3 App Select	Software Application Select per SFF-8079, Tx Channel 3 (Optional)	00	
96	1	Control Tx2 App Select	Software Application Select per SFF-8079, Tx Channel 2 (Optional)	00	
97	1	Control Tx1 App Select	Software Application Select per SFF-8079, Tx Channel 1 (Optional)	00	
98-99	2	Control Reserved98	Reserved	00 00	
100	1	Mask TxRx LOS	Masking bit for TX/RX LOS indicator	00	
101	1	Mask TxFault	Masking bit for TX fault indicator	00	
102	1	Mask Reserved102	Reserved	00	

103	1	Mask Temp AW	Masking bit for Temperature alarm/warning and initialization complete	00	
104	1	Mask Vcc AW	Masking bit for Vcc alarm/warning	00	
105-106	2	Mask Reserved105	Reserved	00 00	
107-109	3	Reserved107	Reserved	00	
110	1	Power	Power Less Than 1W	08	
111-112	2	Reserved111	Reserved	00	
113	1	Channel	Four Channel	10	
114-118	5	Reserved107	Reserved	00	
119-122	4	Password Change Entry Area	Password Change Entry Area (optional)	00 00 00 00	
123-126	4	Password Entry Area	Password Entry Area (Optional)	00 00 00 00	
127	1	Page Select	Page Select Byte	00	
Upper Memory Map Page 00h					
IIC Addr	Size	Name	Description	Values (HEX)	Remarks
128	1	Identifier	QSFP28	11	
129	1	Ext. Identifier	CLEI code present in Page 02h	10	
130	1	Connector	No separable connector	23	
131-138	8	Tranceiver	Code for electronic compatibility or optical compatibility	80 00 00 00 00 00 00 00	
139	1	Encoding	(64B66B)	05	
140	1	BR, nominal	Nominal Bit Rate 25.5GB/s	FF	
141	1	Extended RateSelect Compliance	Tags for Extended RateSelect compliance	00	
142	1	Length(SMF)	Link length supported for SMF fiber in km	00	
143	1	Length (E-50µm)	Link length supported for EBW 50/125 µm fiber, units of 2 m	00	

144	1	Length (50 μ m)	Link length supported for 50/125 μ m fiber, units of 1 m	00	
145	1	Length (62.5 μ m)	Link length supported for 62.5/125 μ m fiber, units of 1 m	00	
146	1	Length (Copper)	Link length supported for copper, units of 1m	-	
147	1	Device Tech	Copper cable unequalized	A0	
148-163	16	Vendor name	MODULETEK	4D 4F 44 55 4C 45 54 45 4B 20 20 20 20 20 20 20	
164	1	Extended Transceiver	Extended Transceiver Codes for InfiniBand	00	
165-167	3	Vendor OUI	QSFP vendor IEEE company ID	00 00 00	
168-183	16	Vendor PN	Part number in Order information	-	
184-185	2	Vendor rev	Revision level for part number provided by vendor (ASCII)	-	
186-187	2	Wavelength	Nominal laser wavelength (Wavelength = value / 20 in nm)	-	
188-189	2	Wavelength Tolerance	Guaranteed range of laser wavelength (+/- value) from Nominal wavelength.(Wavelength Tol. = value/200 in nm)	-	
190	1	Max Case Temp	Maximum Case Temperature in Degrees C.	46	
191	1	CC BASE	Check code for Base ID Fields (addresses 128-190)	-	
192-195	4	Options	Rate Select, TX Disable, TX Fault, LOS, Warning indicators for: Temperature, VCC, RX power, TX Bias	0B 00 00 00	
196-211	16	Vendor SN	Serial number provided by vendor	Programmed by Factory	
212-219	8	Date Code	Year,Month,Day	Programmed by Factory	

220	1	Diagnostic Monitoring Type	Indicates which types of diagnostic monitoring are implemented (if any) in the Module. Bit 1,0 Reserved	00	
221	1	Enhanced options	Indicates which optional enhanced features are implemented in the Module.	00	
222	1	Reserved	Reserved	-	
223	1	CC EXT	Check code for the Extended ID Fields (addresses 192-222)	-	
224-255	32	Vendor Specific	Vendor Specific EEPROM	-	
Upper Memory Map Page 02h					
IIC Addr	Size	Name	Description	Values (HEX)	Remarks
128-255	128	Upper Memory Map	User Code Area	-	
Upper Memory Map Page 8Ah					
IIC Addr	Size	Name	Description	Values (HEX)	Remarks
128-131	4	Firmware Version Number[4]	Firmware Version Number	-	
132-135	4	Datasheet Version Number[4]	Datasheet Version Number	-	
136	1	Security Level	Security Level: 00=Normal Mode 01=User Mode(Level 1) 02=Factory Mode(Level 2)	-	
137-138	2	Vcc ADC	Vcc ADC	-	
139-140	2	Temp ADC	Temp ADC	-	
Upper Memory Map Page F0h					
IIC Addr	Size	Name	Description	Values (HEX)	Remarks
128-131	4	Password1 long	Level 1 Password	00 00 10 11	

Notes:

- 1.Password entry area are write-only bits, read out always 00000000
- 2.Page 00 and page 02 with write protection, enter the security level 1 writeable

User Mode

Level 1 Default Password	Password Can Be Changed	Permissions
00 00 10 11	YES(A0 TF0)	1. Read And Write A0 T00/T02
		2. Read A0 T8A
		3. Read And Write A0 TF0

Cable Mechanical Specifications

Parameter	Symbol	Min	Typ	Max	Unit	Remarks
Wire Gauge		30AWG		26AWG	AWG	
Cable Impedance	Z	95	100	105	Ohm	

Cable dimension

serial number	Standard Wire Gauge AWG	Cable diameter OD (mm)	Minimum bending radius R (mm)
1	30	6.0	28
2	26	7.5	40

Length Tolerance

Serial number	Nominal length L1 (m)	Tolerance range ±(cm)
1	$L1 \leq 2$	2
2	$2 < L1 \leq 4$	4
3	$4 < L1 \leq 5$	6

Weight

Parameter	Symbol	Typ	Unit	Remarks
30AWG Product Weight	G_{D30}	250	g/PCS	1
26AWG Product Weight	G_{D28}	360	g/PCS	1
30AWG Cable Weight	G_{C30}	130	g/M	
26AWG Cable Weight	G_{C28}	240	g/M	
Dust Cap Weight	G_Q	1.40	g/PCS	

Notes:

- 1.The weight of DAC-QSFP-2QSFP-100G-P-xxAWG-1M-D1D1D.
- 2.The weight of unit length cable(two sticks). For example:The weight of DAC-QSFP-2QSFP-100G-P-30AWG-3M-D1D1D is: $250+130*(3-1)+1.4*3=514.2g$

Dimensions

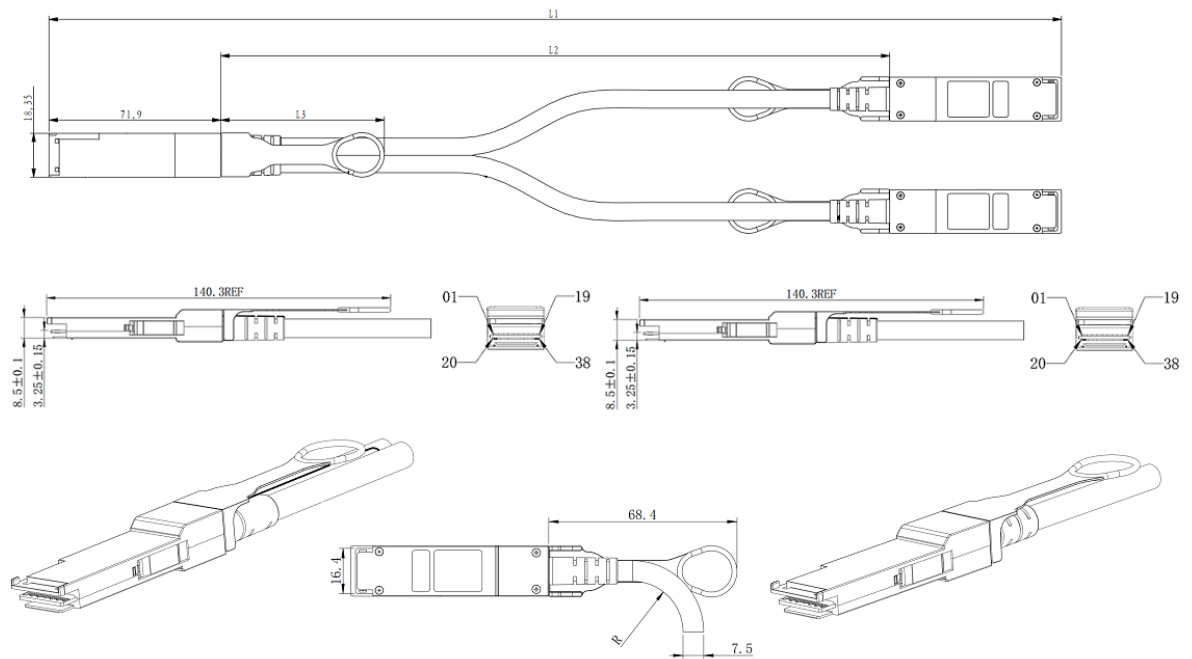

ALL DIMENSIONS ARE $\pm 0.2\text{mm}$ UNLESS OTHERWISE SPECIFIED
UNIT: mm

QSFP Electrical Pad Layout

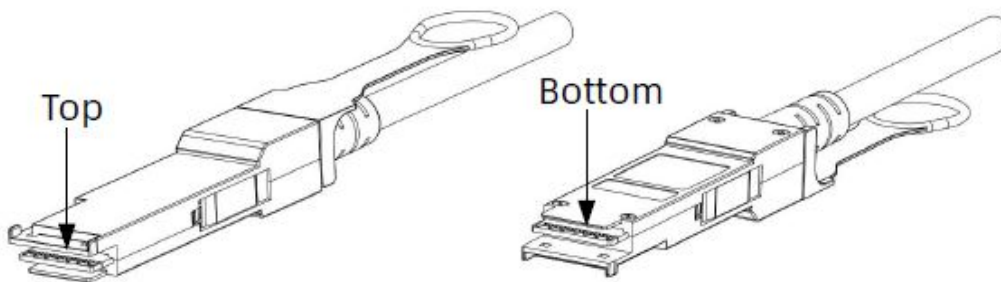
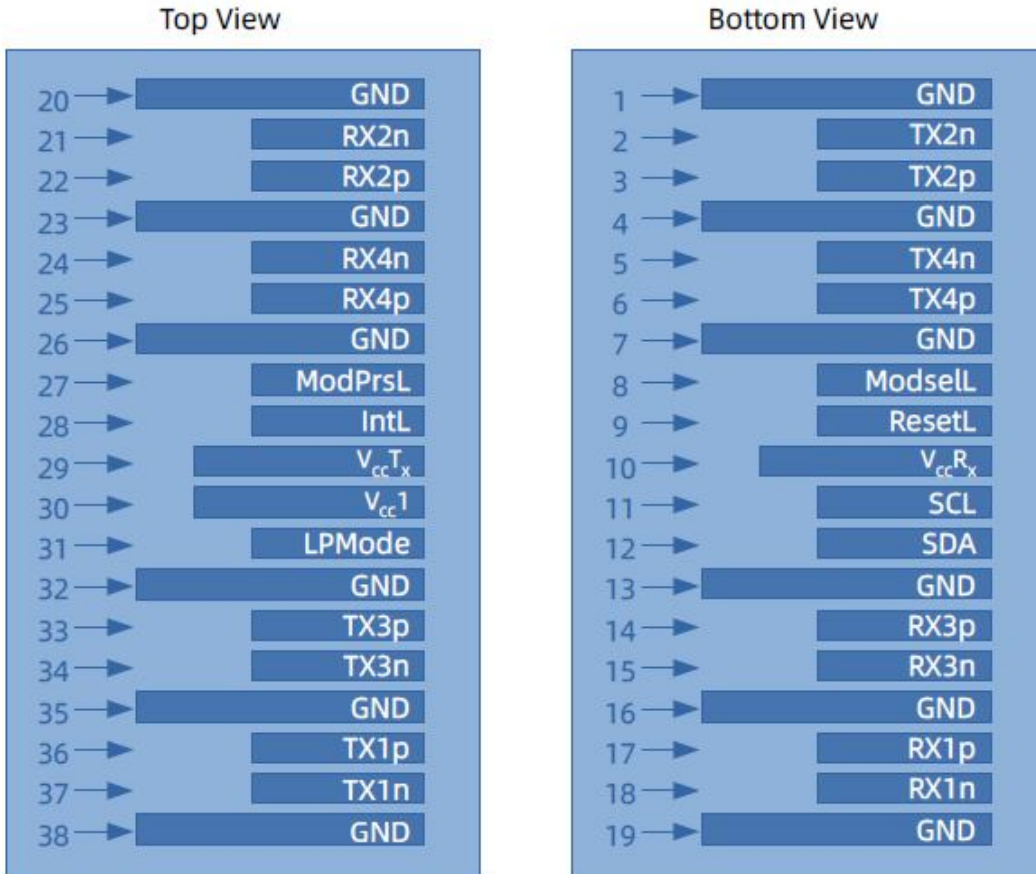

QSFP Pin Assignment

PIN #	Symbol	Description	Remarks
1	GND	Ground	5
2	Tx2n	Transmitter Inverted Data Input, LAN2	
3	Tx2p	Transmitter Non-Inverted Data Input, LAN2	
4	GND	Ground	5
5	Tx4n	Transmitter Inverted Data Input, LAN4	
6	Tx4p	Transmitter Non-Inverted Data Input, LAN4	
7	GND	Ground	5
8	ModSelL	Module select pin, the module responds to two-wire serial communication when low level	1
9	ResetL	Module Reset	2
10	V _{cc} R _X	+3.3V Power Supply Receiver	
11	SCL	2-wire serial interface clock	
12	SDA	2-wire serial interface data	
13	GND	Ground	5
14	Rx3p	Receiver Non-Inverted Data Output, LAN3	
15	Rx3n	Receiver Inverted Data Output, LAN3	
16	GND	Ground	5
17	Rx1p	Receiver Non-Inverted Data Output, LAN1	
18	Rx1n	Receiver Inverted Data Output, LAN1	
19	GND	Ground	5
20	GND	Ground	5
21	Rx2n	Receiver Inverted Data Output, LAN2	
22	Rx2p	Receiver Non-Inverted Data Output, LAN2	
23	GND	Ground	5
24	Rx4n	Receiver Inverted Data Output, LAN4	
25	Rx4p	Receiver Non-Inverted Data Output, LAN4	
26	GND	Ground	5
27	ModPrsL	The module is inserted into the indicate pin and grounded in the module.	3
28	IntL	Interrupt	4
29	V _{cc} T _X	+3.3V Power Supply transmitter	
30	V _{cc} 1	+3.3V Power Supply	
31	LPMoDe	Low Power Mode	5
32	GND	Ground	5

33	Tx3p	Transmitter Non-Inverted Data Input, LAN3	
34	Tx3n	Transmitter Inverted Data Input, LAN3	
35	GND	Ground	5
36	Tx1p	Transmitter Non-Inverted Data Input, LAN1	
37	Tx1n	Transmitter Inverted Data Input, LAN1	
38	GND	Ground	5

Notes:

1. ModSelL is the input pin. The module responds to 2-wire serial communication commands when it is held low by the host. ModSelL allows multiple QSFP modules to be used on a single 2-wire interface bus. If ModSelL is High, the module will not respond to any 2-wire interface communication from the host. ModSelL has internal pull-up resistors in the module
2. The module restart pin, when the low level on the ResetL pin lasts longer than the minimum pulse length, resets the module and restores all user modules to their default state. When performing reset device, the host should ignore all status bits. Until the module reset interrupt is completed, please note that during hot plugging, the module will issue this information to complete the reset interrupt without resetting
3. This pin is active high, indicating that the module is running under a low power module.
4. IntL is the output pin, which is the open collector output and must be pulled up to Vcc on the motherboard. When it is low, it indicates that the module may malfunction. The host uses a 2-wire serial interface to identify the interrupt source
5. Circuit ground is internally isolated from chassis ground.

References

1. IEEE standard 802.3bj. IEEE Standard Department, 2008.