

## DATA SHEET

### MODULETEK: AOC-QSFP-4SFP-100G-aa.aaaM-D1D1C

#### 103.1Gbps QSFP to 4xSFP Active Optical Cable

### Overview

AOC-QSFP-4SFP-100G-aa.aaaM-D1D1C QSFP to 4xSFP active optical cable is used to convert 100G QSFP to 4 25G SFP branches, using full duplex optical components to 4 independent transmission and reception channels, each channel can support a transmission rate of 25.78Gbps.

### Product Features

- QSFP: Compliant with QSFP28 MSA
- SFP: Compliant with SFP+ MSA
- QSFP: 4 independent high-speed full duplex channels
- QSFP: Each channel bit rate at 25.78Gbps
- Support Hot-pluggable
- 850nm VCSEL laser transmitter
- PIN receiver
- Built-in digital diagnostic functions
- OM3 cable lengths up to 70m
- OM4 cable lengths up to 100m
- Single power supply 3.3V
- RoHS-6 Compliant
- Low power consumption (QSFP <2.0W@Single-end, SFP <0.75W@Single-end)
- Operating temperature range (Case Temperature) : Commercial Level: 0°C to 70°C

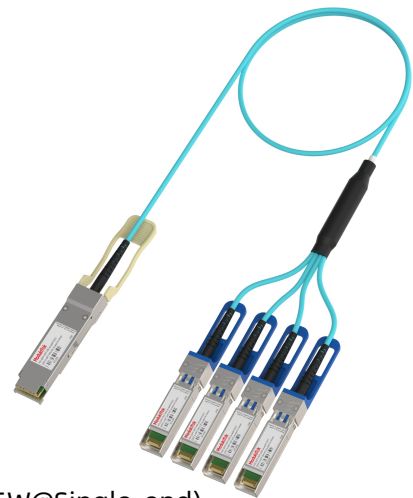

### Applications

- 100G Ethernet Data Center Intra-Rack and Inter-Rack links

## Ordering Information

Part Number	Produce ID	Description	Color on Clasp
AOC-QSFP-4SFP-100G-aa.aaaM-D1D1C	M365401	100G QSFP to 4xSFP Active Optical Cable, Length 1 ~ 100 meters	Beige(QSFP), Blue(SFP)
<b>Notes:</b> 1. Product ID is the abbreviated order number of our company's product standard model 2. Model AOC-QSFP-4SFP-100G-aa.aaaM-D1D1C, where aaa.aaM refers to the length of the AOC cable			
<b>For More Information Or To Order The Above Products, Please Contact:</b>  Email: sales@moduletek.com  ModuleTek Web: <a href="http://www.moduletek.com">www.moduletek.com</a>			

## General Specifications

Parameter	Symbol	Min	Typ	Max	Unit	Remarks
Data Rate (Per Channel)	DR		25.78		Gbps	1
Bit Error Rate	BER			$5 \times 10^{-5}$		2
Operating Temperature	$T_C$	0		70	°C	3
Storage Temperature	$T_{STO}$	-40		85	°C	4
Input Voltage	$V_{CC}$	3.15	3.3	3.46	V	
Maximum Voltage	$V_{MAX}$	-0.5		4.0	V	5

**Notes:**

1. IEEE 802.3
2. Measured with data rate at 25.78Gbps, PRBS  $2^{31}-1$
3. Case temperature
4. Ambient temperature
5. For electrical power interface

## Electrical Characteristics - Transmitter

$V_{CC}=3.15V$  to  $3.46V$ ,  $T_C=0^{\circ}C$  to  $70^{\circ}C$

Parameter	Symbol	Min	Typ	Max	Unit	Remarks
Input differential impedance(SFP)	$R_{IN}$		100		$\Omega$	
Input differential impedance(QSFP)	$R_{IN}$		100		$\Omega$	
Differential Data Input Swing(SFP)	$V_{IN\_PP}$	180		1600	mV	
Differential Data Input Swing(QSFP)	$V_{IN\_PP}$	180		1200	mV	
Transmitter Disable Voltage	$V_D$	2		$V_{CC}$	V	
Transmitter Enable Voltage	$V_{EN}$	$V_{EE}$		$V_{EE}+0.8$	V	

## Electrical Characteristics - Receiver

$V_{CC}=3.15V$  to  $3.46V$ ,  $T_C=0^{\circ}C$  to  $70^{\circ}C$

Parameter	Symbol	Min	Typ	Max	Unit	Remarks
Differential output swing(SFP)	$V_{OUT\_PP}$	370		850	mV	
Differential output swing(QSFP)	$V_{OUT\_PP}$	300		850	mV	
LOS Assert	$V_{LOS\_A}$	2		$V_{CC\_HOST}$	V	
LOS De-Assert	$V_{LOS\_D}$	$V_{EE}$		$V_{EE}+0.8$	V	

## Digital Diagnostic Function

AOC-QSFP-4SFP-100G-aa.aaaM-D1D1C supports the 2-wire serial communication protocol, QSFP defined in SFF-8636, and SFP defined in SFF-8472, which provides access to digital diagnostic information through a 2-wire interface. The internal microcontroller unit provides real-time access to module operating parameters such as module temperature, laser bias current, transmit optical power, receive optical power and module supply voltage. The QSFP module implements the alarm function of the SFF-8636, and SFP module implements the alarm function of the SFF-8472, which alerts the user when specific operating parameters are out of normal range.

QSFP Digital Diagnostic Threshold Range				
Parameter	High Alarm(HEX)	High Warning(HEX)	Low Warning(HEX)	Low Alarm(HEX)
Temperature(°C)	75.00(4B00h)	70.00(4600h)	0.00(0000h)	-5.00(FB00h)
Voltage(V)	3.63(8DCCh)	3.46(8728h)	3.13(7A44h)	2.97(7404h)
Bias Current(mA)	12.00(1770h)	11.50(1676h)	2.00(03E8h)	1.00(01F4h)
Tx Power(dBm)	3.40(5575h)	2.40(43E2h)	-8.40(05A5h)	-9.40(047Ch)
Rx Power(dBm)	3.40(5575h)	2.40(43E2h)	-10.30(03A5h)	-11.30(02E5h)

SFP Digital Diagnostic Threshold Range				
Parameter	High Alarm	High Warning	Low Warning	Low Alarm
Temperature(°C)	75.00(4B00h)	70.00(4600h)	0.00(0000h)	-5.00(FB00h)
Voltage(V)	3.63(8DCCh)	3.46(8728h)	3.13(7A44h)	2.97(7404h)
Bias Current(mA)	12.00(1770h)	11.50(1676h)	2.00(03E8h)	1.00(01F4h)
Tx Power(dBm)	3.40(5575h)	2.40(43E2h)	-8.40(05A5h)	-9.40(047Ch)
Rx Power(dBm)	3.40(5575h)	2.40(43E2h)	-10.30(03A5h)	-11.30(02E5h)

## QSFP A0h Write Protection

Security Level 1 Password (Factory Value)		
Password Entry ADDR	Size	Vaules(HEX)
A0h, 7Bh-7Eh	4	00 00 10 11

AOC-QSFP-4SFP-100G-aa.aaaM-D1D1C QSFP module has the A0 write protection function, which allows users to enter the security level 1 working state and write the contents of Table 00h and Table 02h of the device address A0h. The method to enter the security level 1 working state is to write the security level 1 password sequentially in the 7Bh-7Eh registers of the device address A0h; after entering the security level 1, the user can modify the contents of the 7Fh Table Selection Register of the device address A0h to write the contents of Table 00h and Table 02h. This version module supports users to modify the password of security level 1 by writing a new security level 1 password in the 77h-7Ah register (Password Change Entry) in the device address A0h; the new security level 1 password ranges from 00000000-7FFFFFFF (hex), and the highest bit of the new security level 1 password must be 0b.

## SFP A0h, A2h Write Protection

Security Level 1 Password (Factory value)		
Password Entry ADDR	Size	Vaules(HEX)
Page A2h, 7Bh-7Eh	4	00 00 10 11
Change Security Level 1 Password		
Change Password Entry ADDR	Size	Vaules(HEX)
Page A2h, Table F0h, 80h-83h	4	Programmed by User

AOC-QSFP-4SFP-100G-aa.aaaM-D1D1C SFP module has write protection functions of A0h and A2h, and users can enter the working state of security level 1 and write to the address of module device A0h and table 00h, table 01h and table F0h of A2h. The method to enter the working state of security level 1 is to write the security level 1 password in the 7Bh-7Eh register of the module A2h address in turn. After entering the security level 1, the user can directly write the contents of the A0h device address, or by modifying the contents of the 7Fh table selection register in the A2h address, write to table 00h or table 01h or table F0h. This version module supports users to modify the password of security level 1 by writing a new security level 1 password in the 80h-83h register in the device address F0h table of module A2h. The new security level 1 password ranges from 00000000-7FFFFFFF (hex), and the highest bit of the new security level 1 password must be 0b.

## QSFP A0h Register Map Low 128 Bytes

Lower Memory Map (A0h)				
IIC ADDR	Size	Name	Description	Initial Vaules(HEX)
0	1	Identifier	QSFP28	11
1	1	Revision Compliance	SFF-8636 Rev 2.10	08
2	1	Status	Bit7-Bit3=0000: Reserved Bit2=0: Upper memory Paged (at least upper page 03h implemented) Bit1: Digital state of the IntL Interrupt output pin Bit0: Data Not Ready	Variable
3	1	Channel Status LOS Flag	Tx/Rx LOS Flag	Variable
4	1	Channel Status TX Adapt EQ Fault/TxFault Flag	Bit7-Bit4: This product does not support this function Bit3-Bit0: TxFAULT Flag	Variable
5	1	Channel Status LOL Flag	Tx/Rx CDR LOL Flag	Variable
6	1	Module Monitor Temperature Alarm/Warning Flag	Bit7-Bit4: Temperature Alarm/Warning Flag Bit3-Bit2: Reserved Bit1: This product does not support this function Bit0: initialization completion flag bit	Variable
7	1	Module Monitor Vcc Alarm/Warning Flag	Vcc Alarm/Warning Flag	Variable
8	1	Vendor Specific	Vendor Specific information	00
9-10	2	Channel Mon RxPower Alarm/Warning Flag	RxPower Alarm/Warning Flag	Variable
11-12	2	Channel Mon TxBias Alarm/Warning Flag	TxBias Alarm/Warning Flag	Variable
13-14	2	Channel Mon TxPower Alarm/Warning Flag	TxPower Alarm/Warning Flag	Variable
15-18	4	Reserved	Reserved channel monitor flags	00 00 00 00

19-21	3	Vendor Specific	Vendor Specific information	00 00 00
22-23	2	Module Monitor Temperature	Temperature diagnosis, unit is 1/256°C	Variable
24-25	2	Reserved	Reserved	00 00
26-27	2	Module Monitor Voltage	Supply Voltage diagnosis, unit is 100uV	Variable
28-29	2	Reserved	Reserved	00 00
30-33	4	Vendor Specific	Vendor Specific information	00 00 00 00
34-35	2	Channel Mon Rx1 Power	Rx1 average receive power diagnosis, unit of 0.1uW	Variable
36-37	2	Channel Mon Rx2 Power	Rx2 average receive power diagnosis, unit of 0.1uW	Variable
38-39	2	Channel Mon Rx3 Power	Rx3 average receive power diagnosis, unit of 0.1uW	Variable
40-41	2	Channel Mon Rx4 Power	Rx4 average receive power diagnosis, unit of 0.1uW	Variable
42-43	2	Channel Mon Tx1 Bias	Tx1 bias current diagnosis, unit of 2uA	Variable
44-45	2	Channel Mon Tx2 Bias	Tx2 bias current diagnosis, unit of 2uA	Variable
46-47	2	Channel Mon Tx3 Bias	Tx3 bias current diagnosis, unit of 2uA	Variable
48-49	2	Channel Mon Tx4 Bias	Tx4 bias current diagnosis, unit of 2uA	Variable
50-51	2	Channel Mon Tx1 Power	Tx1 average receive power diagnosis, unit of 0.1uW	Variable
52-53	2	Channel Mon Tx2 Power	Tx2 average receive power diagnosis, unit of 0.1uW	Variable
54-55	2	Channel Mon Tx3 Power	Tx3 average receive power diagnosis, unit of 0.1uW	Variable
56-57	2	Channel Mon Tx4 Power	Tx4 average receive power diagnosis, unit of 0.1uW	Variable
58-73	16	Reserved	Reserved	00 00 00 00 00 00 00 00 00 00 00 00 00 00 00 00
74-81	8	Vendor Specific	Vendor Specific information	00 00 00 00 00 00 00 00
82-85	4	Reserved	Reserved	00 00 00 00

86	1	Control TxDisable	Bit7-Bit4=0000: Reserved Bit3: Bit of Channel4 Laser disable control Bit2: Bit of Channel3 Laser disable control Bit1: Bit of Channel2 Laser disable control Bit0: Bit of Channel1 Laser disable control	Variable
87	1	Control Rx Rate Select	This product does not support this function, Initialize to 00 (hex)	00
88	1	Control Tx Rate Select	This product does not support this function, Initialize to 00 (hex)	00
89-92	4	Reserved	Reserved	00 00 00 00
93	1	Control Power	This product does not support this function, Initialize to 00 (hex)	00
94-97	4	Reserved	Reserved	00 00 00 00
98	1	Control Tx/Rx CDR	Bit7=1 Channel 4 Tx CDR On Bit6=1 Channel 3 Tx CDR On Bit5=1 Channel 2 Tx CDR On Bit4=1 Channel 1 Tx CDR On Bit3=1 Channel 4 Rx CDR On Bit2=1 Channel 3 Rx CDR On Bit1=1 Channel 2 Rx CDR On Bit0=1 Channel 1 Rx CDR On	FF
99	1	Control LP/TxDis, IntL/LOSL	Bit7-Bit2=0 Reserved Bit1 LPMODE/TxDis input signal control Bit0 IntL/LOSL output signal control	Variable
100	1	Mask Tx/Rx LOS	Masking Tx/Rx LOS	Variable
101	1	Mask Tx Adapt EQ Fault/TxFault	Bit7-Bit4: This product does not support this function Bit3-Bit0: Masking TxFault	Variable
102	1	Mask Tx/Rx CDR LOL	Masking Tx/Rx CDR LOL	Variable
103	1	Mask Temperature Alarm/Warning	Masking Temperature Alarm/Warning	Variable
104	1	Mask Vcc Alarm/Warning	Masking Voltage Alarm/Warning	Variable
105-106	2	Vendor Specific	Vendor Specific information	00 00
107	1	Max Power Consumption	Maximum power consumption of module (single-end), 2.0W, unit of 0.1W	14
108-109	2	Propagation Delay	This product does not support this function, Initialize to 00 (hex)	00
110	1	Free Side Device Properties	Bit7-Bit4=0000 Power 1.5W or higher Bit3=0 The far end is managed and complies with SFF-8472 Bit2-Bit0=000 3.3 V	00

111-112	2	Assigned for use by PCI Express	This product does not support this function, Initialize to 00 (hex)	00 00
113	1	Free Side Device Properties	Bit7=0 Reserved Bit6-Bit4=100 4 far-ends with 1 channel implemented in each Bit3-Bit0=0000 Near-End implementation	40
114	1	Use by microQSFP	This product does not support this function, Initialize to 00 (hex)	00
115	1	ModSELL wait time	This product does not support this function, Initialize to 00 (hex)	00
116	1	Secondary Extended Spec Compliance	100G Base AOC	01
117-118	1	Reserved	Reserved	00 00
119-122	4	Password Change Entry Area (optional)	Modify security level 1 password entry, power-up default 00000000 (hex); readback not supported after writing	00 00 00 00
123-126	4	Password Entry Area (optional)	Security level 1 password entry, power-up default 00000000 (hex); readback not supported after writing	00 00 00 00
127	1	Page Select Byte	Table selection, select A0h high 128 byte page	00

## QSFP A0h Register Map High 128 Bytes

Upper Memory Map Page 00h				
ICC Addr	Size	Name	Description	Initial Value(HEX)
128	1	Identifier	QSFP28	11
129	1	Ext. Identifier	Bit7-Bit6=01: Power Class 2 Single-end of Module (<2.0W) Bit5=0: Power Class 8 not implemented Bit4=0: No CLEI code Bit3=1: Tx with CDR function Bit2=1: Rx with CDR function Bit1-Bit0=00: Power Classes 1 to 4	4C
130	1	Connector Type	No separable connector	23
131-138	8	Specification Compliance	100G Base AOC	80 00 00 00 00 00 00 00
139	1	Encoding	NRZ	03
140	1	Nominal bit rate	Unit is 100Mbps	FF

141	1	Extended Rate Select Compliance	No rate selection function	00
142	1	Length (SMF)	SMF transmission distance, unit of 1km	00
143	1	Length (OM3 50 um)	OM3 transmission distance, unit of 2m	00
144	1	Length (OM2 50 um)	OM2 transmission distance, unit of 1m	00
145	1	Length (OM1 62.5 um)	OM1 transmission distance, unit of 1m	00
146	1	Length(Active Cable or Copper)	Cable Length, unit of 1m	According to the needs of customers
147	1	Device technology	Bit7-Bit4=0000: 850nm VCSEL Bit3=0: No wavelength control Bit2=0: Uncooled transmitter device Bit1=0: Pin detector Bit0=0: Transmitter not tunable	00
148-163	16	Vendor name	MODULETEK	ASCII Format
164	1	Extended Module	InfinBand application are not supported	00
165-167	3	Vendor OUI	IEEE Company Identifier for the vendor	00 00 00
168-183	16	Vendor PN	Vendor Part Number	ASCII Format
184-185	2	Vendor rev	Vendor Part Revision Number	Defined by vendor
186-187	2	Wavelength	850nm, unit of 0.05nm	42 68
188-189	2	Wavelength tolerance	±20nm, unit of 0.005nm	1F 40
190	1	Max case temp	Max case temp is 70°C, unit of °C	46
191	1	CC_BASE	The check code of Bytes 128-190	Defined by vendor
192	1	Extended Specification Compliance Codes	100G Base AOC	01

193	1	Options	<p>Bit7=0 Reserved</p> <p>Bit6=1 LPMode/TxDis input signal is configurable using byte 99, bit 1</p> <p>Bit5=1 IntL/RxLOSL output signal is configurable using byte 99, bit 0</p> <p>Bit4-Bit3=00 This product does not support this function</p> <p>Bit2=1 Tx input equalizers fixed-programmable implemented</p> <p>Bit1=1 Rx output emphasis fixed-programmable implemented</p> <p>Bit0=1 Rx output amplitude fixed-programmable implemented</p>	67
194	1	Options	<p>Bit7=1: Tx CDR On/Off Control implemented</p> <p>Bit6=1: Rx CDR On/Off Control implemented</p> <p>Bit5=1: Tx CDR Loss of Lock (LOL) flag implemented</p> <p>Bit4=1: Rx CDR Loss of Lock (LOL) flag implemented</p> <p>Bit3=1: Rx Squelch Disable implemented</p> <p>Bit2=1: Rx Output Disable capable implemented</p> <p>Bit1=1: Tx Squelch Disable implemented</p> <p>Bit0=1: Tx Squelch implemented</p>	FF
195	1	Options	<p>Bit7=1: Memory Page 02 provided</p> <p>Bit6=0: Memory Page 01 not implemented</p> <p>Bit5=0: Rate selection funtion not implemented</p> <p>Bit4=1: Tx-DISABLE implemented</p> <p>Bit3=1: Tx-FAULT signal implemented</p> <p>Bit2=0: Tx Squelch implemented to reduce OMA</p> <p>Bit1=1: Tx Los of signal implemented</p> <p>Bit0=0: Pages 20-21h not implemented</p>	9A
196-211	16	Vendor SN	Vendor Part Serial Number	Defined by vendor
212-219	8	Date Code	Date	Defined by vendor
220	1	Diagnostic Monitoring Type	<p>Bit7-Bit6=00: Reserved</p> <p>Bit5=1: Temperature monitoring implemented</p> <p>Bit4=1: Supply voltage monitoring implemented</p> <p>Bit3=1: Received power measurements type is average power</p> <p>Bit2=1: Transmitter power measurement supported</p> <p>Bit1-Bit0=00: Reserved</p>	3C

221	1	Enhanced Options	Bit7-Bit5=000: Reserved Bit4=1: The initialization complete flag Bit3=0: Rate selection is not supported Bit2=0: Reserved Bit1=0: TC readiness flag not implemented Bit0=1: Software reset is implemented	11
222	1	BR, nominal	Nominal baud rate, units of 250 Mbps	68
223	1	CC_EXT	The check code of Byte 192-222	Defined by vendor
224-255	32	Vendor Specific	Vendor Specific information	Defined by vendor
<b>Upper Memory Map Page 02h</b>				
IIC Addr	Size	Name	Description	Initial Value(HEX)
128-255	128	User-writable EEPROM	User defined, readable and writeable under security level 1	User-defined
<b>Upper Memory Map Page 03h</b>				
IIC Addr	Size	Name	Description	Initial Vlan(HEX)
128-129	2	Temp High Alarm	Temperature high alarm	See Table Of Threshold Ranges
130-131	2	Temp Low Alarm	Temperature low alarm	See Table Of Threshold Ranges
132-133	2	Temp High Warning	Temperature high warning	See Table Of Threshold Ranges
134-135	2	Temp Low Warning	Temperature low warning	See Table Of Threshold Ranges
136-143	8	Reserved	Reserved	00 00 00 00 00 00 00 00
144-145	2	Vcc High Alarm	Voltage high alarm	See Table Of Threshold Ranges
146-147	2	Vcc Low Alarm	Voltage low alarm	See Table Of Threshold Ranges

148-149	2	Vcc High Warning	Voltage high warning	See Table Of Threshold Ranges
150-151	2	Vcc Low Warning	Voltage low warning	See Table Of Threshold Ranges
152-159	8	Reserved	Reserved	00 00 00 00 00 00 00 00
160-175	16	Vendor Specific	Vendor Specific information	Defined by vendor
176-177	2	Rx Power High Alarm	RX power high alarm	See Table Of Threshold Ranges
178-179	2	Rx Power Low Alarm	RX power low alarm	See Table Of Threshold Ranges
180-181	2	Rx Power High Warning	RX power high warning	See Table Of Threshold Ranges
182-183	2	Rx Power Low Warning	RX power low warning	See Table Of Threshold Ranges
184-185	2	Tx Bias High Alarm	Tx Bias current high alarm	See Table Of Threshold Ranges
186-187	2	Tx Bias Low Alarm	Tx Bias current low alarm	See Table Of Threshold Ranges
188-189	2	Tx Bias High Warning	Tx Bias current high warning	See Table Of Threshold Ranges
190-191	2	Tx Bias Low Warning	Tx Bias current low warning	See Table Of Threshold Ranges
192-193	2	Tx Power High Alarm	TX power high alarm	See Table Of Threshold Ranges

194-195	2	Tx Power Low Alarm	TX power low alarm	See Table Of Threshold Ranges
196-197	2	Tx Power High Warning	TX power high warning	See Table Of Threshold Ranges
198-199	2	Tx Power Low Warning	TX power low warning	See Table Of Threshold Ranges
200-207	8	Reserved	Reserved	00 00 00 00 00 00 00 00
208-215	8	Reserved	Reserved	00 00 00 00 00 00 00 00
216-223	8	Vendor Specific	Vendor Specific information	Defined by vendor
224	1	Tx EQ, Rx Emphasis Magnitude ID	Bit7-Bit4=1010 Max Tx input equalization supported Bit3-Bit0=0111 Max Rx output emphasis supported	A7
225	1	Rx output amplitude support indicators	Bit7-Bit6=00 Reserved Bit5-Bit4=00 Peak-to-peak amplitude stays constant Bit3-Bit0=1111 Rx output amplitude supported	0F
226	1	Control options advertising	Reserved	00
227	1	Control options advertising	Bit7-Bit6=00 This product does not support this function Bit5-Bit4=00 Reserved Bit3=1 Tx Force Squelch implemented Bit2=0 RxLOSL fast mode is not supported Bit1=1 TxDis fast mode is supported Bit0=0 Reserved	0A
228	1	Control options advertising	This product does not support this function, Initize to 00 (hex)	00
229	1	Control options advertising	This product does not support this function, Initize to 00 (hex)	00
230	1	Optional Channel Controls	This product does not support this function, Initize to 00 (hex)	00
231	1	Optional Channel Controls	Bit7-Bit4=0 Reserved Bit3 Tx4 Force Squelch Bit2 Tx3 Force Squelch Bit1 Tx2 Force Squelch Bit0 Tx1 Force Squelch	Variable

232	1	Optional Channel Controls	Reserved	00
233	1	Optional Channel Controls	This product does not support this function, Initize to 00 (hex)	00
234	1	Optional Channel Controls	Bit7-Bit4 Tx1 input equalizer control Bit3-Bit0 Tx2 input equalizer control	Variable
235	1	Optional Channel Controls	Bit7-Bit4 Tx3 input equalizer control Bit3-Bit0 Tx4 input equalizer control	Variable
236	1	Optional Channel Controls	Bit7-Bit4 Rx1 output emphasis control Bit3-Bit0 Rx2 output emphasis control	Variable
237	1	Optional Channel Controls	Bit7-Bit4 Rx3 output emphasis control Bit3-Bit0 Rx4 output emphasis control	Variable
238	1	Optional Channel Controls	Bit7-Bit4: Rx1 output amplitude Bit3-Bit0: Rx2 output amplitude	Variable
239	1	Optional Channel Controls	Bit7-Bit4: Rx3 output amplitude Bit3-Bit0: Rx4 output amplitude	Variable
240	1	Optional Channel Controls	Bit7-Bit4: Rx4-Rx1 squelch enable or disable Bit3-Bit0: Tx4-Tx1 squelch enable or disable	Variable
241	1	Optional Channel Controls	Bit7-Bit4=0000: Rx4-Rx1 output enable Bit3-Bit0=0000: This product does not support this function	00
242-243	2	Channel Monitor Masks	Masking Bit for Rx power Alarm/Warning	Variable
244-245	2	Channel Monitor Masks	Masking Bit for Tx Bias current Alarm/Warning	Variable
246-247	2	Channel Monitor Masks	Masking Bit for Tx power Alarm/Warning	Variable
248-249	2	Channel Monitor Masks	Reserved	00 00
250-251	2	Channel Monitor Masks	Reserved	00 00
252-255	4	Reserved	Reserved	00 00 00 00

**Notes:**

1. The alarm threshold information can be modified according to the customer's definition, please contact us if you have any modification requirements.

## SFP IIC Memory Map(Page A0h, Unlisted Fields are Blank/Empty)

IIC ADDR	Size	Name	Description	Vaules(HEX)
0	1	Identifier	SFP	03
1	1	Ext. Identifier	Two-wire Interface	04
2	1	Connector	No separable connector	23
3-10	8	Transceiver	25G Base AOC	00 00 00 00 00 08 00 00
11	1	Encoding	Not Explicitly Specified	00
12	1	BR, Nominal	Nominal Bit Rate 25.78Gbps	FF
13	1	Rate Identifier	Type of rate select functionality	00
14	1	Length(9um)-km	Link Length in Thousands of Meters/SMF = NA	00
15	1	Length(9um)-100m	Link Length in Hundreds of Meters/SMF = NA	00
16	1	Length(50um)-10m	50-micron MMF Link Length = NA	00
17	1	Length(62.5um)-10m	62.5-micron MMF Link Length = NA	00
18	1	Length(Active Cable or Copper)-m	Cable Length-m	According to the needs of customers
19	1	Length(Active Cable or Copper)-m	Cable Length-m	00
20-35	16	Vendor name	MODULETEK	ASCII Format
36	1	Transceiver	25G Base AOC	01
37-39	3	Vendor OUI	SFP Vendor IEEE Company ID	00 00 00
40-55	16	Vendor PN	The Part number in the Ordering Information	ASCII Format
56-59	4	Vendor rev	Programmed by Factory	Programmed by Factory
60-61	2	Wavelength	850nm, unit of 0.05nm	03 52
62	1	Reserved	Unallocated	00
63	1	CC_BASE	Check sum of bytes 0-62	Programmed by Factory
64	1	Transceiver Options	BIT7=0 Reserved BIT6=0 Reserved BIT5=0 The module power level is 1 (Less than 1.0w) BIT4=1 Paging implemented function BIT3=1 Retimer or CDR indicator BIT2=0 A uncooled laser transmitter implementation BIT1=0 The module power Level is 1 (Less than 1.0w) BIT0=0 A conventional limiting receiver output	18

65	1	Transceiver Options	BIT7=0 Receiver decision threshold implemented is not realized BIT6=0 Tunable wavelength lasers are not used BIT5=0 RATE_SELECT functionality is not realized BIT4=1 Have TX_DIS function BIT3=1 Have TX_Fault function BIT2=0 Loss of Signal is not realized BIT1=1 Have RX_LOS function BIT0=0 Reserved	1A
66	1	BR, max	Maximum signal rate	68
67	1	BR, min	Maximum signal rate deviation	00
68-83	16	Vendor SN	Vendor SN	Programmed by Factory
84-91	8	Date code	Year, Month, Day	Programmed by Factory
92	1	Diagnostic Monitoring Type	BIT7=0 Compatible with SFF-8472 requirements BIT6=1 Realize digital diagnostic function BIT5=1 Realized internal calibration function BIT4=0 Externally calibration is not realized BIT3=1 Received power is the averaged power BIT2=0 Don't need address change BIT1=0 Reserved BIT0=0 Reserved	68
93	1	Enhanced Options	BIT7=1 Have optional Alarm/Warning flags implements function BIT6=1 Have soft TX_DIS monitor and control functions BIT5=1 Have soft TX_Fault monitor function BIT4=1 Have soft RX_LOS monitor function BIT3=0 No software RATE_SEL monitor and control functions BIT2=0 The optional soft rate selection control funtion is not implemented by SFF-8079 BIT1=0 The optional soft rate selection control funtion is not implemented by SFF-8431 BIT0=0 Reserved	F0
94	1	SFF-8472 Compliance	As defined by SFF8472 version 12.3	08
95	1	CC_BASE	Check sum of bytes 64-94	Programmed by Factory
96-127	32	Vendor Specific	Vendor Specific EEPROM	Programmed by Factory
128-255	128	Reserved	Vendor Specific	Programmed by Factory

## SFP IIC Memory Map(Page A2h LOW, Unlisted Fields are Blank/Empty)

IIC ADDR	Size	Name	Description	Vaules(HEX)
<b>Alarm/Warning Thresholds</b>				
00-01	2	Temp High Alarm	Temperature high alarm	See Table Of Threshold Ranges
02-03	2	Temp Low Alarm	Temperature low alarm	See Table Of Threshold Ranges
04-05	2	Temp High Warning	Temperature high warning	See Table Of Threshold Ranges
06-07	2	Temp Low Warning	Temperature low warning	See Table Of Threshold Ranges
08-09	2	Voltage High Alarm	Voltage high alarm	See Table Of Threshold Ranges
10-11	2	Voltage Low Alarm	Voltage low alarm	See Table Of Threshold Ranges
12-13	2	Voltage High Warning	Voltage high warning	See Table Of Threshold Ranges
14-15	2	Voltage Low Warning	Voltage low warning	See Table Of Threshold Ranges
16-17	2	Bias High Alarm	Bias current high alarm	See Table Of Threshold Ranges
18-19	2	Bias Low Alarm	Bias current low alarm	See Table Of Threshold Ranges
20-21	2	Bias High Warning	Bias current high warning	See Table Of Threshold Ranges
22-23	2	Bias Low Warning	Bias current low warning	See Table Of Threshold Ranges
24-25	2	TX Power High Alarm	TX power high alarm	See Table Of Threshold Ranges
26-27	2	TX Power Low Alarm	TX power low alarm	See Table Of Threshold Ranges
28-29	2	TX Power High Warning	TX power high warning	See Table Of Threshold Ranges
30-31	2	TX Power Low Warning	TX power low warning	See Table Of Threshold Ranges

32-33	2	RX Power High Alarm	RX power high alarm	See Table Of Threshold Ranges
34-35	2	RX Power Low Alarm	RX power low alarm	See Table Of Threshold Ranges
36-37	2	RX Power High Warning	RX power high warning	See Table Of Threshold Ranges
38-39	2	RX Power Low Warning	RX power low warning	See Table Of Threshold Ranges
40-55	16	Optional A/W Thresholds	Unrealized	-
<b>Calibration Constant For External Calibration Option</b>				
56-59	4	RX-PWR(4)	The module only realizes internal correction funtion	00 00 00 00
60-63	4	RX_PWR(3)	The module only realizes internal correction funtion	00 00 00 00
64-67	4	RX_PWR(2)	The module only realizes internal correction funtion	00 00 00 00
68-71	4	RX_PWR(1)	The module only realizes internal correction funtion	3F 80 00 00
72-75	4	RX_PWR(0)	The module only realizes internal correction funtion	00 00 00 00
76-77	2	TX_I(Slope)	The module only realizes internal correction funtion	01 00
78-79	2	TX_I(Offset)	The module only realizes internal correction funtion	00 00
80-81	2	TX_PWR(Slope)	The module only realizes internal correction funtion	01 00
82-83	2	TX_PWR(Offset)	The module only realizes internal correction funtion	00 00
84-85	2	T(Slope)	The module only realizes internal correction funtion	01 00
86-87	2	T(Offset)	The module only realizes internal correction funtion	00 00
88-89	2	V(Slope)	The module only realizes internal correction funtion	01 00
90-91	2	V(Offset)	The module only realizes internal correction funtion	00 00
92-94	3	Unallocated	-	00 00 00
95	1	Checksum	Byte 95 contains the low order 8 bits of the sum of bytes 0-94	-
<b>A/D Values And Status Bits</b>				
96-97	2	Temperature MSB/LSB	Temperature measured value	Variable
98-99	2	Vcc MSB/LSB	Voltage measured value	Variable
100-101	2	Tx Bias MSB/LSB	Bias current measured value	Variable

102-103	2	TX Power MSB/LSB	Measured TX output power	Variable
104-105	2	RX Power MSB/LSB	Measured RX input power	Variable
106-107	2	Laser T/W MSB/LSB	Function not implemented	00 00
108-109	2	TEC current MSB/LSB	Function not implemented	00 00
110	1	Status/Control	BIT7 TX_Dis Pin States BIT6 Soft TX_Dis Pin States BIT5 RS(1) Pin States BIT4 RS0 Pin States BIT3 Soft RS0 control bit BIT2 TX_Fault Pin States BIT1 Rx_LOS Pin States BIT0 Data_Ready_Bar Pin States	Variable
111	1	Reserved	Reserved for SFF-8079	00
112	1	Alarm Flags	BIT7 Temp High Alarm BIT6 Temp Low Alarm BIT5 Vcc High Alarm BIT4 Vcc Low Alarm BIT3 TX Bias High Alarm BIT2 TX Bias Low Alarm BIT1 TX Power High Alarm BIT0 TX Power Low Alarm	Variable
113	1	Alarm Flags	BIT7 RX Power High Alarm BIT6 RX Power Low Alarm BIT5-BIT2 Alarm bit not realized BIT1-BIT0 Reserved	Variable
114	1	Tx Input EQ Control	BIT7-BIT4 High-speed mode input equalization setting value; the default value for power-up is 3, which can be used to change the module input equalization value BIT3-BIT0 Low-speed mode input equalization setting value; not used, the default value for power-up is 3	33
115	1	Rx Out Emphasis Control	BIT7-BIT4 High-speed mode output emphasis setting value; the default value for power-up is 3, which can be used to change the module output emphasis value BIT3-BIT0 Low-speed mode output emphasis setting value; not used, the default value for power-up is 3	33
116	1	Warning Flags	BIT7 Temp High Warning BIT6 Temp Low Warning BIT5 Vcc High Warning BIT4 Vcc Low Warning BIT3 TX Bias High Warning BIT2 TX Bias Low Warning BIT1 TX Power High Warning BIT0 TX Power Low Warning	Variable
117	1	Warning Flags	BIT7 RX Power High Warning BIT6 RX Power Low Warning BIT5-BIT2 Warning bit not realized BIT1-BIT0 Reserved	Variable

118	1	Ext Status/Control	BIT7-BIT4 BIT2 Reserved BIT3 Soft RS(1) control bit BIT1=0 The module power level is 1 (Less than 1.0w) BIT0=0 The module power level is 1 (Less than 1.0w)	The default for power-up is 00
119	1	Ext Status/Control	BIT7-BIT5 Unallocated BIT4=0 Not Applicable BIT3=0 Not Applicable BIT2=0 Not Applicable BIT1 TX CDR status bit, a value of 0 indicates that the CDR is locked, whereas a value of 1 indicates loss of lock of the CDR BIT0 Rx CDR status bit, a value of 0 indicates that the CDR is locked, whereas a value of 1 indicates loss of lock of the CDR	Variable
<b>General Use Fields</b>				
120-122	3	Reserved	Reserved	00 00 00
123-126	4	Security Level Password	Security level password input area, the written password can be displayed and the default value is 00 00 00 00	00 00 00 00
127	1	Table Select	Table Select	00

## QSFP Block-Diagram-of-Transceiver

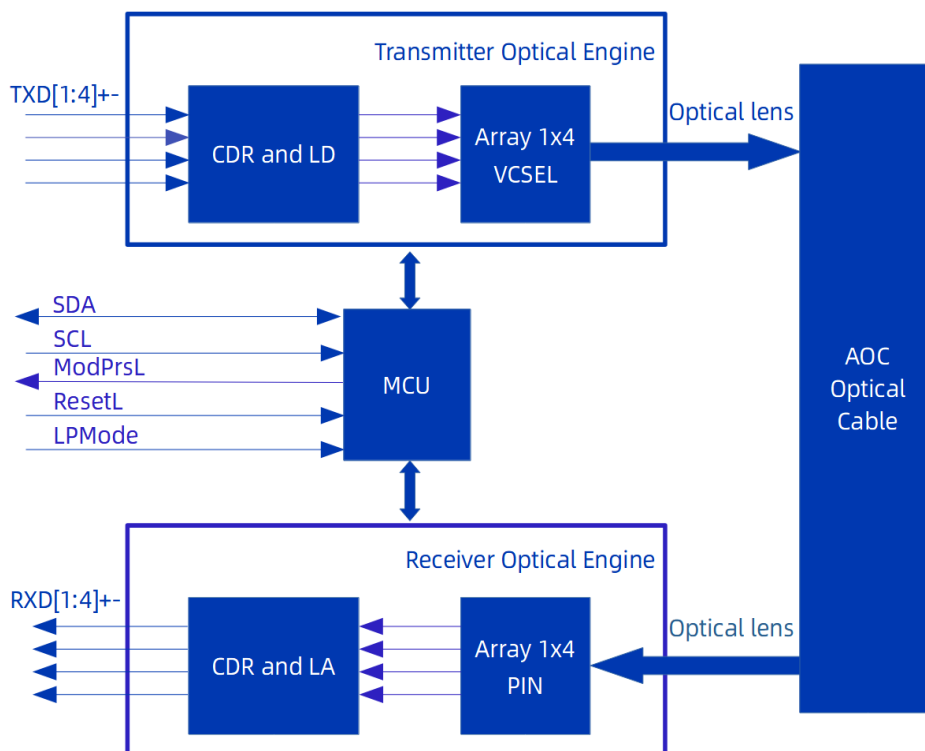

## QSFP Functions Description

AOC-QSFP-4SFP-100G-aa.aaaM-D1D1C QSFP module is manufactured by advanced COB (Chip on Board) technology and consists of a microcontroller, an optical engine at the transmitting end and an optical engine at the receiving end. The module has built-in clock and data recovery functions, and the working rate range of the transmitter and receiver of the built-in CDR is 25.5-26Gbps. If you need another version of the rate range, you can contact us for special customization.

The microcontroller communicates with the host computer via a 2-wire serial communication interface and provides module control, status reporting, and monitoring (DOM) functions in accordance with the SFF-8636 standard.

The transmitter-side optical engine consists of a 4-channel clock data recovery circuit (CDR) and 4-channel laser driver circuit (LD), a 4-channel VCSEL laser. The high-speed differential electrical signal output by the host computer is restored and shaped by the CDR, which is amplified by the laser driver to drive the VCSEL laser to produce the optical signal, and the optical signal is coupled to the optical fiber through the optical lens. The optical engine integrates a photodiode for detection, which is used for output optical power detection.

The receiving optical engine includes a 4-channel photodiode (PIN), a 4-channel signal amplifier (TIA/LA) and a 4-channel receiver clock data recovery circuit (CDR). The optical signal in the optical fiber is coupled to the receiving photodiode (PIN) through an optical lens and con-

verted into photocurrent. After the photocurrent signal is enhanced by the amplifier, it is sent to the CDR circuit and the clock and data signal recovery is completed. Finally, it is output to the host in the form of high-speed differential signal. The microcontroller reads the signal strength (modulation amplitude) received by the photodiode and reports the loss of the received signal if it is lower than the set threshold.

Both the transmitter and receiver have the squelch function. When the transmitter has a signal input, the waveform displayed by the oscilloscope of the transmitter light access is an eye diagram shape, and the waveform displayed by the oscilloscope of the transmitter light access when there is no signal input is a straight line, and the actual measured optical power is lower than the normal value of optical power, but not zero; When the incident light at the receiving end has a signal input, access to the oscilloscope shows that the waveform of the output electrical signal is an eye diagram shape, and when there is no signal input, access to the oscilloscope shows that the waveform of the output electrical signal is a straight line.

## SFP Block-Diagram-of-Transceiver

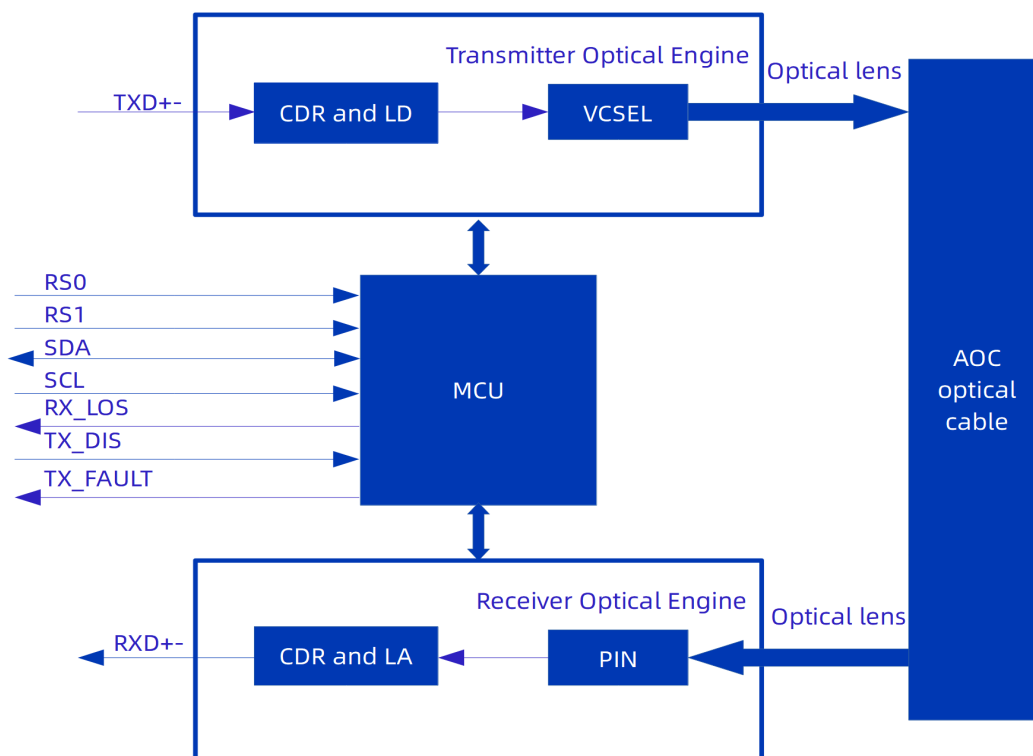

## SFP Functions Description

AOC-QSFP-4SFP-100G-aa.aaaM-D1D1C SFP module is manufactured by advanced COB (Chip on Board) technology and consists of a microcontroller, an optical engine at the transmitting

end and an optical engine at the receiving end. The module has built-in clock and data recovery functions.

The microcontroller communicates with the host through a 2-wire serial communication interface, providing module control function, status reporting function and monitoring function (DOM). This product conforms to the SFF-8472 standard.

The transmitter optical engine includes a transmitter clock data recovery circuit (CDR) and a laser driver circuit (LD), a VCSEL laser, and a detection photodiode (MPD). The high-speed differential electrical signal output by the host computer is restored and shaped by the CDR, which is amplified by the laser driver to drive the VCSEL laser to produce the optical signal, and the optical signal is coupled to the optical fiber through the optical lens. The optical engine integrates a photodiode for detection, which is used for output optical power detection.

The receiving optical engine includes a photodiode (PIN), a signal amplifier (TIA/LA) and a receiver clock data recovery circuit (CDR). The optical signal in the optical fiber is coupled to the receiving photodiode (PIN) through an optical lens and converted into photocurrent. After the photocurrent signal is enhanced by the amplifier, it is sent to the CDR circuit and the clock and data signal recovery is completed. Finally, it is output to the host in the form of high-speed differential signal. The microcontroller reads the signal strength (modulation amplitude) received by the photodiode and reports the loss of the received signal if it is lower than the set threshold.

Both the transmitter and receiver have the function of suppression. When there is a signal input at the transmitter, the waveform displayed by the transmitted light access oscilloscope is an eye graph shape, and when there is no signal input, the waveform displayed by the transmitted light access oscilloscope is a straight line, and the actual measured optical power is lower than the normal optical power value, but not zero. When the incident light at the receiving has a signal input, the access oscilloscope shows that the waveform of the output electrical signal is an eye graph shape, and when there is no signal input, the oscilloscope shows that the waveform of the output electrical signal is a straight line.

## Optical Cable Details

Parameter	Min	Typ	Max	Unit	Remarks
Jacket Material		LSZH			
Jacket Color		Aqua Green			We can provide according to the needs of customers
Flammability Rating		OFN			We can provide according to the needs of customers
Outer Diameter	2.8	3.0	3.2	mm	
Tensile Load (Short Term)			200	N	
Tensile Load (Long Term)			100	N	
Crush Resistance	10			N/mm	IEC 60794-1-21
Impact Resistance	0.5			N.m	IEC 60794-1-21
Flexing	300			Cycles	IEC 60794-1-21
Twist Bend					IEC 60794-1-21
Cable to SFP+ Plug Connection			90	N	
Bend Radius (Short Term)	25			mm	
Bend Radius (Long Term)	30			mm	

## Dimensions

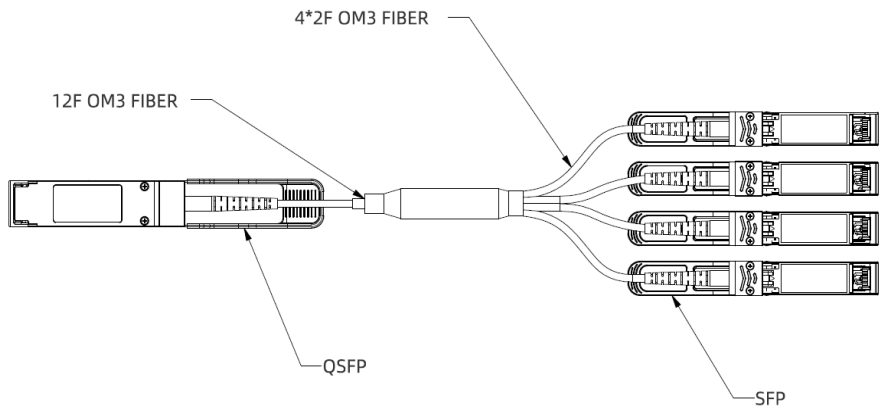
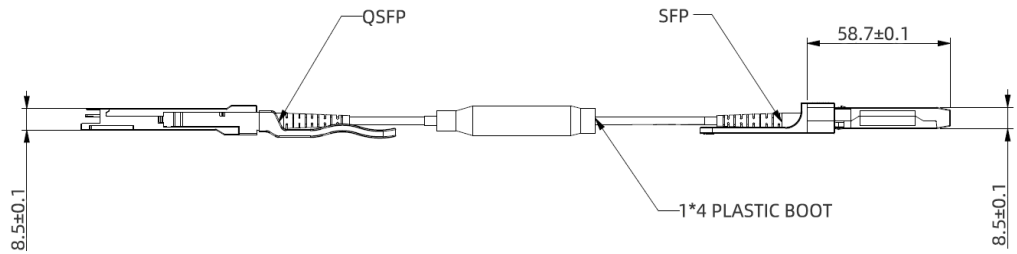
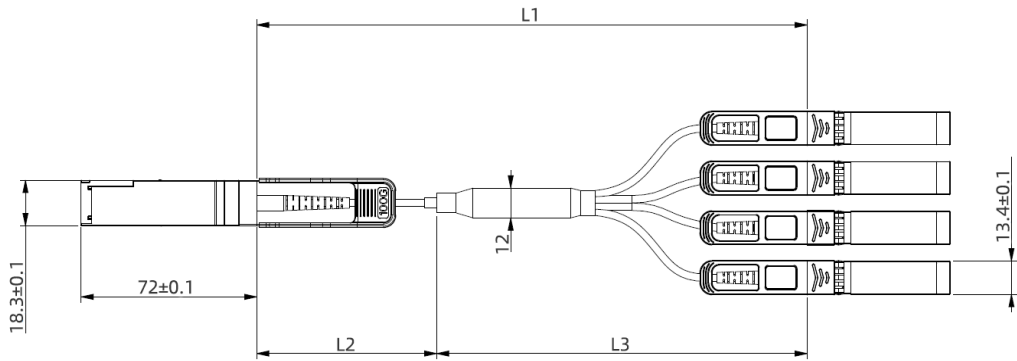

ALL DIMENSIONS ARE  $\pm 0.2\text{mm}$  UNLESS OTHERWISE SPECIFIED  
UNIT: mm

Length (L1)	Length (L2)	Length (L3)
1M	0.33M	0.67M
2M	0.67M	1.33M
3M	1M	2M
$\geq 5\text{M}$	L1-L3	3M

## QSFP Electrical Pad Layout

Top View Of Board

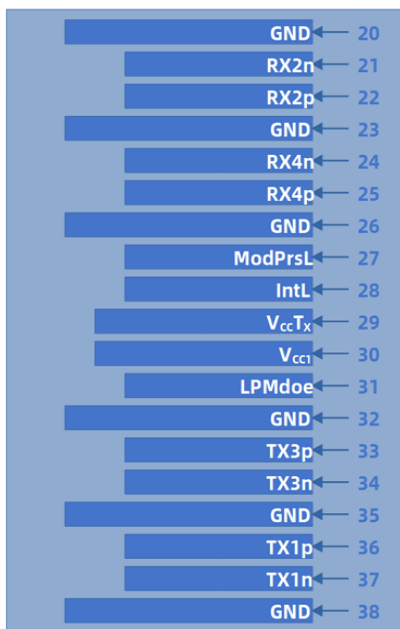

Bottom View Of Board

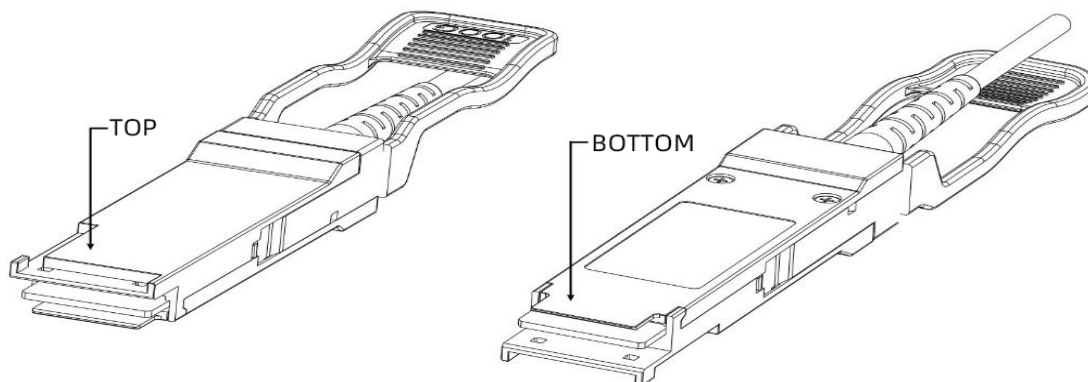
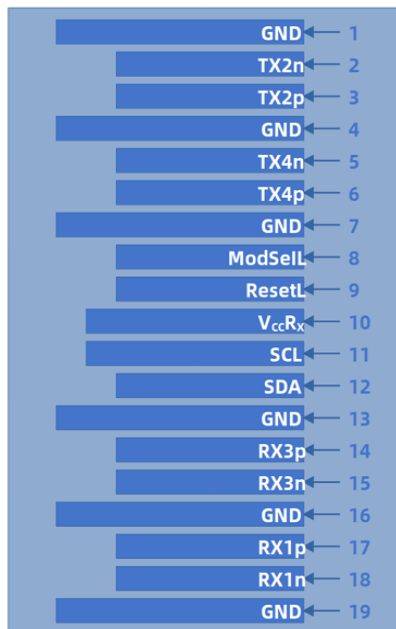

## SFP Electrical Pad Layout

Top View Of Board

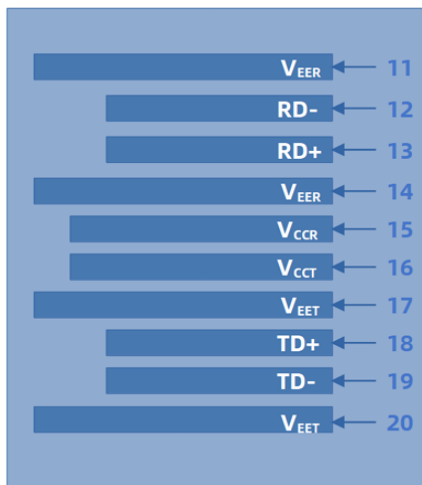

Bottom View Of Board

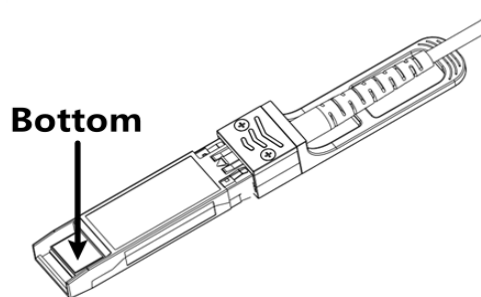
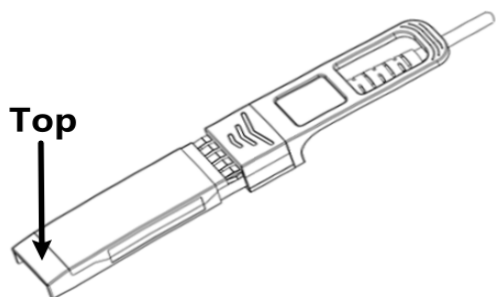
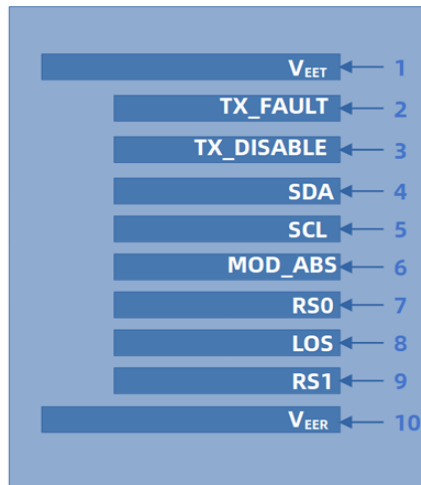

## QSFP Pin Assignment

PIN #	Symbol	Description	Remarks
1	GND	Ground	5
2	Tx2n	Transmitter Inverted Data Input, LAN2	
3	Tx2p	Transmitter Non-Inverted Data Input, LAN2	
4	GND	Ground	5
5	Tx4n	Transmitter Inverted Data Input, LAN4	
6	Tx4p	Transmitter Non-Inverted Data Input, LAN4	
7	GND	Ground	5
8	ModSelL	Module select pin, the module responds to two-wire serial communication when low level	1
9	ResetL	Module Reset	2
10	V <sub>cc</sub> R <sub>X</sub>	+3.3V Power Supply Receiver	
11	SCL	2-wire serial interface clock	
12	SDA	2-wire serial interface data	
13	GND	Ground	5
14	Rx3p	Receiver Non-Inverted Data Output, LAN3	
15	Rx3n	Receiver Inverted Data Output, LAN3	
16	GND	Ground	5
17	Rx1p	Receiver Non-Inverted Data Output, LAN1	
18	Rx1n	Receiver Inverted Data Output, LAN1	
19	GND	Ground	5
20	GND	Ground	5
21	Rx2n	Receiver Inverted Data Output, LAN2	
22	Rx2p	Receiver Non-Inverted Data Output, LAN2	
23	GND	Ground	5
24	Rx4n	Receiver Inverted Data Output, LAN4	
25	Rx4p	Receiver Non-Inverted Data Output, LAN4	
26	GND	Ground	5
27	ModPrsL	The module is inserted into the indicate pin and grounded in the module.	3
28	IntL	Interrupt	4
29	V <sub>cc</sub> T <sub>X</sub>	+3.3V Power Supply transmitter	
30	V <sub>cc</sub> 1	+3.3V Power Supply	
31	LPMMode	Low Power Mode	5
32	GND	Ground	5

33	Tx3p	Transmitter Non-Inverted Data Input, LAN3	
34	Tx3n	Transmitter Inverted Data Input, LAN3	
35	GND	Ground	5
36	Tx1p	Transmitter Non-Inverted Data Input, LAN1	
37	Tx1n	Transmitter Inverted Data Input, LAN1	
38	GND	Ground	5

**Notes:**

1. ModSelL is the input pin. The module responds to 2-wire serial communication commands when it is held low by the host. ModSelL allows multiple QSFP modules to be used on a single 2-wire interface bus. If ModSelL is High, the module will not respond to any 2-wire interface communication from the host. ModSelL has internal pull-up resistors in the module
2. The module restart pin, when the low level on the ResetL pin lasts longer than the minimum pulse length, resets the module and restores all user modules to their default state. When performing reset device, the host should ignore all status bits. Until the module reset interrupt is completed, please note that during hot plugging, the module will issue this information to complete the reset interrupt without resetting
3. This pin is active high, indicating that the module is running under a low power module.
4. IntL is the output pin, which is the open collector output and must be pulled up to Vcc on the motherboard. When it is low, it indicates that the module may malfunction. The host uses a 2-wire serial interface to identify the interrupt source
5. Circuit ground is internally isolated from chassis ground.

## SFP Pin Assignment

PIN #	Symbol	Description	Remarks
1	V <sub>EET</sub>	Transmitter ground (common with receiver ground)	1
2	TX_FAULT	Transmitter Fault	
3	TX_DISABLE	Transmitter Disable. Laser output disabled on high or open	2
4	SDA	2-wire Serial Interface Data Line	3
5	SCL	2-wire Serial Interface Clock Line	3
6	MOD_ABS	Module Absent. Grounded within the module	3
7	RS0	No connection required	
8	LOS	Loss of Signal indication. Logic 0 indicates normal operation	4
9	RS1	No connection required	1
10	V <sub>EER</sub>	Receiver ground (common with transmitter ground)	1
11	V <sub>EER</sub>	Receiver ground (common with transmitter ground)	1
12	RD <sup>-</sup>	Receiver Inverted DATA out. AC coupled	
13	RD <sup>+</sup>	Receiver Non-inverted DATA out. AC coupled	
14	V <sub>EER</sub>	Receiver ground (common with transmitter ground)	1
15	V <sub>CCR</sub>	Receiver power supply	
16	V <sub>CCT</sub>	Transmitter power supply	
17	V <sub>EET</sub>	Transmitter ground (common with receiver ground)	1
18	TD <sup>+</sup>	Transmitter Non-Inverted DATA in. AC coupled	
19	TD <sup>-</sup>	Transmitter Inverted DATA in. AC coupled	
20	V <sub>EET</sub>	Transmitter ground (common with receiver ground)	1

### Notes:

1. Circuit ground is isolated from chassis ground
2. Disabled: T<sub>DIS</sub>>2V or open, Enabled: T<sub>DIS</sub><0.8V
3. Should Be pulled up with 4.7k –10k ohm on host board to a voltage between 2V and 3.6V
4. LOS is open collector output

## References

1. IEEE standard 802.3. IEEE Standard Department, 2018.
2. FIBRE CHANNEL Physical Interface-6 (FC-PI-6). Rev3.10 October 25, 2013.
3. SFF-8402 SFP+ 1X 28 Gb/s Pluggable Transceiver Solution (SFP28). Rev1.1 September 13, 2014.
4. SFF-8432 SFP+ Module and Cage. Rev5.2a November 30, 2018.
5. SFF-8419 SFP+ Power and Low Speed Interface. Rev1.3 June 11, 2015.
6. SFF-8472 Management Interface for SFP+. Rev12.3 July 29,2018.
7. SFF-8636 Specification for Management Interface for 4-lane Modules and Cables. Rev 2.10a September 24, 2019.